

Guidance and Control Laws for Quadrotor UAV

Tain-Sou Tsay,

Department of Aeronautical Engineering,
National Formosa University,
64, Wen Hua Road, Huwei, Yunlin, 63208, Taiwan
ttsay@nfu.edu.tw

Abstract

In this literature, guidance and control laws using a basic control system have been proposed for analyses and designs of a Quadrotor. The basic control system includes: (a) height Control system using velocity stabilizing in the inner loop; (b) roll, pitch and yaw attitude control systems using angular rate stabilizing in inner loops. Base upon the basic control system, the X_B and Y_B body axes velocities control laws and locus tracking laws are added. This application is different from conventional velocity, and position control techniques of conventional fix-fin UAV's. The major merit of the proposed method is the controlled Quadrotor can tracking the target quickly while keep heading almost not be changed. The proposed method is verified by vast digital simulations. They give good performance.

Keywords : Quadrotor, Guidance and Control Laws, Locus Tracking

1. Introductions

Unmanned Aerial Vehicles (UAVs) have been found potential applications in military and civilian purposes. The UAVs are expected to become much more common soon because of their potential in preventing pilot exposure to danger. Quadrotor is a UAV system consisting of four independent propellers at each corner of a cross frame (Fig.1a). One pair of propellers of the Quadrotor rotate clockwise and the other pair rotate counter-clockwise. It has vertical take-off and landing capabilities. It gives higher maneuverability and hovering capabilities also. The concept of Quadrotor was first experimented in 1907 by Brequet and Richet[1]. In the last few years, many researching groups [2-7] are working to exploit the potential advantage of Quadrotors for the future.

A Quadrotor setup is controlled by manipulating thrust forces from individual rotors as well as balancing drag torque. For hovering, all rotors apply a constant thrust force as illustrated in Fig. 1b(c), thus keeping the aircraft balanced. To control vertical movement, the motor speed is increased or decreased simultaneously, thus having a lower or higher total thrust but still maintaining balance. For attitude control, the yaw angle (ψ) may be controlled by manipulating the torque balance, depending on which direction the aircraft should rotate. The total thrust force still remains balanced, and therefore, no altitude change occurs. For positive yawing, the speed of propellers 2 and 4 is increased by the same amount and the speed of propellers 1 and 3 is decreased by the same amount. This can be shown in Fig. 1b(a) and 1b(b). In a

similar way, the roll angle (ϕ) or pitch angle (θ) can be manipulated applying differential thrust forces on opposite rotors as illustrated in Fig. 1 b(d).

For lateral motion, speed of propellers 2 and 4 is changed by the same amount conversely. After recovered to original speeds, a constant moving speed with a certain rolling angle (ϕ). Reversing speed commands of propellers 2 and 4 those have been actuated, the lateral moving speed and the rolling angle will be recovered to original values. The longitudinal motion is almost not disturbed from the lateral motion (neglects aerodynamic couplings). This implies the Quadrotor can approach the target without changing the heading (i.e., changing the yawing angle). For longitudinal motion, speed of propellers 1 and 3 is changed by the same amount conversely. Similar to behaviors of the lateral motion, constant moving speed with a certain or zero pitching angle (θ) will be made after recovered to original values.

For positive yawing, the speed of propellers 2 and 4 is increased by the same amount and the speed of propellers 1 and 3 is decreased by the same amount. The reaction forces of four propellers create yawing moment without disturbing the vertical motion. Lateral and longitudinal motions are almost not disturbed also. Therefore, one can create constant longitudinal or lateral motion and yawing for omni-directional surveillance. It is similar to pitch a rotating baseball.

The above discussions give the Quadrotor has better operating freedom than that of helicopter or fix-fin UAVs. Therefore, new guidance and control

laws must be developed for the Quadrotor to get optimal application. This is the motivation of this paper.

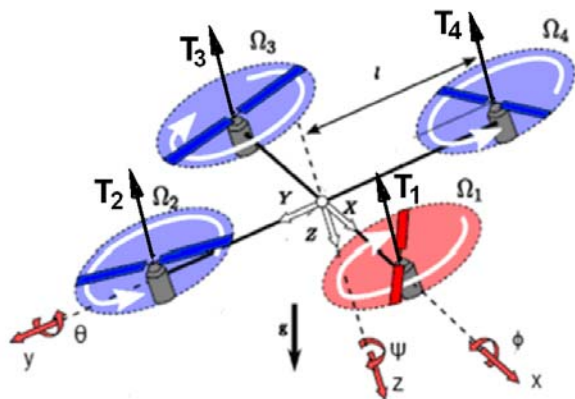

Fig.1a. The coordinate definition of the considered system.

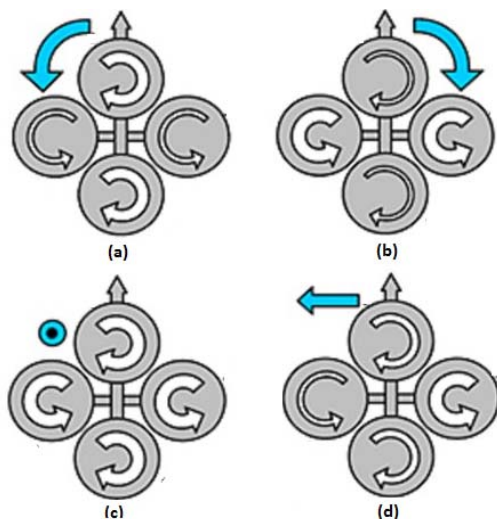

Fig. 1b. Quadrotor dynamics, (a) and (b) difference in torque to manipulate the yaw angle(ψ); (c) hovering motion and vertical propulsion due to balanced torques; (d) difference in thrust to manipulate the roll angle (ϕ) and lateral motion.

Different controllers designed for the Quadrotor configurations exist in literatures. Cranfield University’s LQR controller[8], Swiss Federal Institute of Technology’s PID and LQ controllers [9] and Lakehead University’s PD[5] controller are examples to the controller developed on Quadrotors linearized dynamic models. Among some other control methods of Quadrotor vehicles are CNRS and Grenoble University’s Global Stabilization [10], Swiss Federal Institute of Technology’s Full Control of a Quadrotor[11] and Versailles Engineering Laboratory’s Backstepping Control[12] that takes into account the nonlinear dynamics of the vehicles.

In this paper, a basic control system using PI

controllers will be developed and verified first. The basic control system includes: (a)height control system using velocity stabilizing in the inner loop; (b)roll, pitch and yaw attitude controls using angular rate stabilizing in inner loops. Based upon the basic control system, new guidance laws are evaluated and applied for using the special characteristic of the Quadrotor. They include velocity, position control laws, and selected by the switching control algorithm.

The organization of this paper is given as follows: in Section II, mathematical models of the Quadrotor are evaluated for developing guidance and control laws. In Section III, (1)basic control system configuration design, (2)analyses and designs of the basic control design, (3)application conceptual designs of the basic control system, and (4)conceptual design of locus tracking designs are presented. In Section IV, simulation verifications show goodness of the proposed guidance and control laws.

2. Mathematical model of the Quadrotor

2.1 Coordinate System Definition

The coordinate definition of the Quadrotor is shown in Fig.1a[1] in which shown rotating direction, speed(Ω), arm(l), lifting direction and thrust(T), attitude angle(ϕ, θ, ψ), etc. one pair of propellers of Quadrotor rotate clockwise and the other pair rotate counter-clockwise.

2.2 Kinematic of Quadrotor

The relationship between the rotating speed and the thrust of propeller [13-16] is given below:

$$T_i = b\Omega_i^2; \Omega_i \geq 0 \tag{1}$$

Based upon the coordinate definition shown in Fig.1, Total thrust(u_1) of Z-axis, angular moments of rolling, pitching and yawing axes(u_2, u_3, u_4) are in the form of

$$\begin{aligned} u_1 &= -(T_1 + T_2 + T_3 + T_4); \\ u_2 &= l(T_4 - T_2); \\ u_3 &= l(T_1 - T_3) \\ u_4 &= d(-T_1 + T_2 - T_3 + T_4) \end{aligned} \tag{2}$$

where d is the ratio of thrust to angular moment, l is the position of propeller from the central gravity. Eq.(2) can be rewritten as

$$\begin{aligned}
 u_1 &= -b(\Omega_1 + \Omega_2 + \Omega_3 + \Omega_4); \\
 u_2 &= lb(\Omega_4 - \Omega_2); \\
 u_3 &= lb(\Omega_1 - \Omega_3) \\
 u_4 &= db(-\Omega_1 + \Omega_2 - \Omega_3 + \Omega_4)
 \end{aligned}
 \tag{3}$$

Using Eqs.(1), (2) and (3), the equation of motion of the Quadrotor can be represented as

$$\begin{bmatrix} \dot{u} \\ \dot{v} \\ \dot{w} \end{bmatrix} = \frac{1}{m} \begin{bmatrix} F_x \\ F_y \\ F_z \end{bmatrix} + g \begin{bmatrix} -\sin\theta \\ \cos\theta \sin\phi \\ \cos\theta \cos\phi \end{bmatrix} - \begin{bmatrix} qw - rv \\ ru - pw \\ pv - qu \end{bmatrix}
 \tag{4}$$

where u, v, w are body-axis velocities; p, q, r are angular rates; ϕ, θ, ψ are attitude angles; g is the gravity and m is the total mass. F_x, F_y, F_z are total three-axis forces

$$\begin{bmatrix} F_x \\ F_y \\ F_z \end{bmatrix} = \begin{bmatrix} 0 \\ 0 \\ u_1 \end{bmatrix} + \begin{bmatrix} C_{fx} \\ C_{fy} \\ C_{fz} \end{bmatrix}
 \tag{5}$$

where C_{fx}, C_{fy}, C_{fz} are three-axis aerodynamic forces. They can be neglected for low speed operations. In this work, they are neglected. Derivatives of angular rates(p, q, r) are given below:

$$\begin{bmatrix} \dot{p} \\ \dot{q} \\ \dot{r} \end{bmatrix} = \begin{bmatrix} u_2 / I_{xx} + qr \frac{I_{yy} - I_{zz}}{I_{xx}} \\ u_3 / I_{yy} + pr \frac{I_{zz} - I_{xx}}{I_{yy}} \\ u_4 / I_{zz} + pq \frac{I_{xx} - I_{yy}}{I_{zz}} \end{bmatrix}
 \tag{6}$$

where I_{xx}, I_{yy}, I_{zz} are moment inertia. Eqs.(4) and (5) are equations of six degree of freedom(6DOF). Derivations of attitude(ϕ, θ, ψ) and position(X, Y, Z) are given as in the form of

$$\begin{bmatrix} \dot{\phi} \\ \dot{\theta} \\ \dot{\psi} \end{bmatrix} = \begin{bmatrix} 1 & \tan\theta \sin\phi & \tan\theta \cos\phi \\ 0 & \cos\phi & -\sin\phi \\ 0 & \sec\theta \sin\phi & \sec\theta \cos\phi \end{bmatrix} \begin{bmatrix} p \\ q \\ r \end{bmatrix}
 \tag{7}$$

$$\begin{bmatrix} \dot{X} \\ \dot{Y} \\ \dot{Z} \end{bmatrix} = \begin{bmatrix} \cos\theta \cos\psi & \sin\phi \sin\theta \cos\psi - \cos\phi \sin\psi & \cos\phi \sin\theta \cos\psi + \sin\phi \sin\psi \\ \cos\theta \sin\psi & \cos\phi \cos\psi + \sin\phi \sin\theta \sin\psi & \cos\phi \sin\theta \sin\psi - \sin\phi \cos\psi \\ -\sin\theta & \sin\phi \cos\theta & \cos\phi \cos\theta \end{bmatrix} \begin{bmatrix} u \\ v \\ w \end{bmatrix}
 \tag{8}$$

Fig.2 shows the simulating block diagram[17-19] of the Quadrotor will be used in this work.

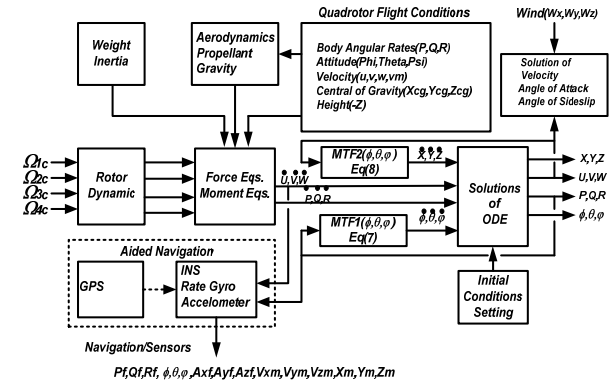

Fig.2. Simulation block diagram of the Quadrotor.

3. Guidance and Control Laws

3.1 Basic Control System Designs

The Basic Control System is discussed and designed first. It will be used for guidance laws development. The relationship between thrust(T_i) and total thrust and angular momentum can be evaluated from Eq.(2) and represented as

$$\begin{bmatrix} T_1 \\ T_2 \\ T_3 \\ T_4 \end{bmatrix} = \begin{bmatrix} -1/4 & 0 & +1/2 & -1/4 \\ -1/4 & -1/2 & 0 & +1/4 \\ -1/4 & 0 & -1/2 & -1/4 \\ -1/4 & +1/2 & 0 & +1/4 \end{bmatrix} \begin{bmatrix} -(T_1 + T_2 + T_3 + T_4) \\ T_4 - T_2 \\ T_1 - T_3 \\ -T_1 + T_2 - T_3 + T_4 \end{bmatrix}
 \tag{9}$$

Eq.(9) is called as a mixer. Using Eqs.(1) and (2), the Basic Control Configuration is designed and shown in Fig.3 in which the Quadrotor dynamic is shown in Fig.2. Eq.(9) gives the maneuverability of the Quadrotor is limited by maximal thrust of the propeller(T_i). Therefore, limitation for command ($u_{1c}, u_{2c}, u_{3c}, u_{4c}$) shown in Fig.3 must be added for preventing uncontrollable nonlinear dynamics.

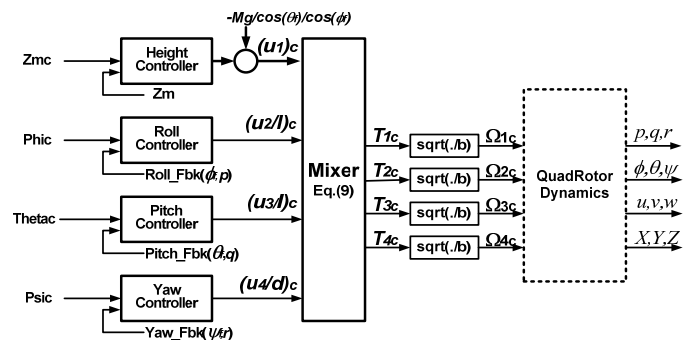

Fig.3. The Basic Control Configuration.

Fig.3 shows that there are four input command and

output controls. They are altitude control command (Z_{mc}) and three attitude control command ($Phic, Thetac, Psic$). Feedback datum for command tracking and stabilization are altitude measurement Z_{mf} , vertical speed w_f , angular rates (p_f, q_f, r_f) and attitudes (ϕ_f, θ_f, ψ_f). Outputs of the basic control ($\Omega_{1c}, \Omega_{2c}, \Omega_{3c}, \Omega_{4c}$) are rotating speed of propellers. Proportion plus Integration (PI) control laws are used for command tracking and disturbance rejection. Control laws are given below:

$$u_{1c} = K_{iz}[(K_{oz} + K_{ozi}/s)(Z_{mc} - Z_{mf}) - w_f] - mg/\cos\theta_f \cos\phi_f \quad (10)$$

$$u_{2c} = K_{ip}[(K_{op} + K_{opi}/s)(Phic - \phi_f) - p_f] \quad (11)$$

$$u_{3c} = K_{iq}[(K_{oq} + K_{oqi}/s)(Thetac - \theta_f) - q_f] \quad (12)$$

$$u_{4c} = K_{ir}[(K_{or} + K_{ori}/s)(Psic - \psi_f) - r_f] \quad (13)$$

where $K(*)$ are loop gains will be selected. They are determined by bandwidth of command tracking and inner loop gain crossover frequencies of each channel. In this work, 1Hz for gain crossover frequency and 0.2Hz for bandwidth are used.

3.2 Verifications for the Basic Control System

In this subsection, the Basic Control System will be designed and verified by vast digital simulations. System parameters used is given in Table 1[20].

Table 1: Parameters of the quadrotor[20].

Parameters	Value	unit
m	4.34	Kg
l	0.315	m
b	1.2953×10^{-5}	
d	0.008	
I_{xx}	0.0820	$Kg \cdot m^2$
I_{yy}	0.0845	$Kg \cdot m^2$
I_{zz}	0.1377	$Kg \cdot m^2$

Fig.4 shows performance of command trackings of the controlled system. Fig.5 shows corresponding speeds of the Quadrotor. Fig.4(a) shows that the Quadrotor flies to 100m height by vertical motion mode first. Fig.4(b) shows time responses of the rolling control; Fig.4(c) shows time responses of the pitching control; and Fig.4(d) shows time responses of the yawing control; Fig.4 shows that the controlled system gives good performance and the couplings between attitude and altitude are limited. This is the major merit of the Quadrotor.

Fig.5(a) shows X_B -axis speed(u); Fig.5(b) shows the Y_B -axis speed(v); Fig.5(c) shows the Z_B -axis speed(w); and Fig.5(d) shows the total speed V_m . Fig.4(b) and Fig.5(b) give that positive rolling angle

increases positive lateral speed v ; and negative rolling angle increasing negative lateral speed v . It implies that if there is no negative rolling angle actuation applied; the quadrotor gets positive lateral speed, zero longitudinal speed and zero rolling angle. Therefore, the quadrotor can approach the target using lateral motion by keeping heading. Fig.4(c) and Fig.5(a) show longitudinal motion by changing the pitching angle. Fig.4(d) and Fig.5(d) show speed u and v are not disturbed by changing the yawing angle. It will be shown that the lateral and longitudinal motions on inertial axis are almost not disturbed also by changing the yawing angle. Fig.6 shows the flight locus.

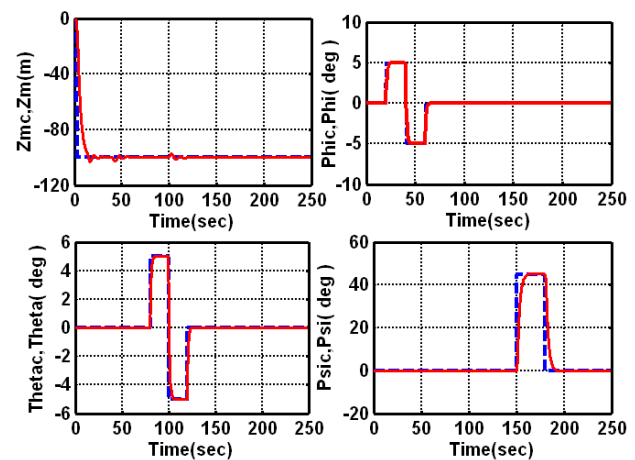

Fig.4. Command tracking performance of the Basic Control System;(a)Heigh control(Z_{mc}, Z_m);(b)Rolling control ($Phic, Phi$); (c)Pitching control($Thetac, Theta$); and (d) Yawing control($Psic, Psi$).

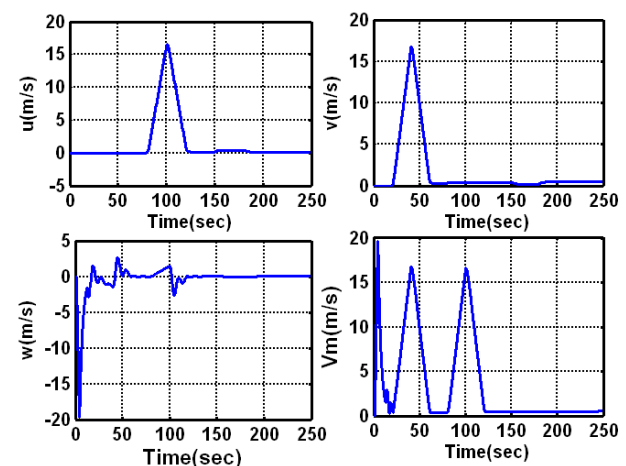

Fig.5. Corresponding vehicle speeds of the Basic Control System;(a)Speed u ;(b)speed v ; (c)speed w ; and (d) speed V_m .

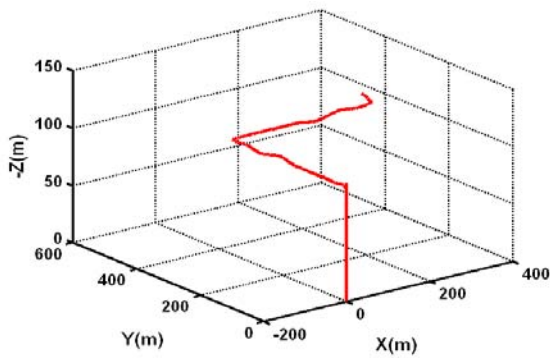

Fig.6. The flight locus

Figs.(7), (8) and (9) show another simulation verifications. The Quadrotor is first flight to 100m high vertically before 20", and then forward speed along X_B axis is created by a constant pitching angle (5degrees) between 20" and 60", and the third changing the yawing angle to 45degrees between 80" and 180". Fig.8 and Fig.9 show that the moving direction and speed of the vehicle are not disturbed by the changing the heading of the Quadrotor. The behavior is similar to pitch a rotating baseball horizontally. Therefore, one can create constant longitudinal or lateral motion and yawing for omni-directional surveillance. It is not really need the platform for the imaging seeker for large angle surveillance.

Simulating results shown in Figs. 4 to 9 give the Quadrotor can provide new operating behaviors. One can develop new guidance law for special application.

3.3 Application of the basic control system

In this subsection, a guidance laws is proposed first for the Quadrotor to simulate the behavior of the conventional fix-fin flight vehicle. It can be done easily. The Conceptual design is give below:

- (1)Speed Control for X_B -Axis: it is corresponding to forward propellant controls of the conventional fix-fin flight vehicle. The output control is the pitching angle command $Thetac$;
- (2)Zero Speed Control for Y_B -Axis: it is corresponding to small lateral maneuverability of the conventional fix-fin flight vehicle. The output control is the rolling angle command $Phic$;
- (3)Yawing angle control: it is corresponding to the yawing angle control by the rudder of the conventional fix-fin flight vehicle. The output control is yawing angle command $Psic$;
- (4)Altitude control: it is corresponding to the height control by elevators of the conventional fix-fin flight vehicle. The output control is the high command Zmc .

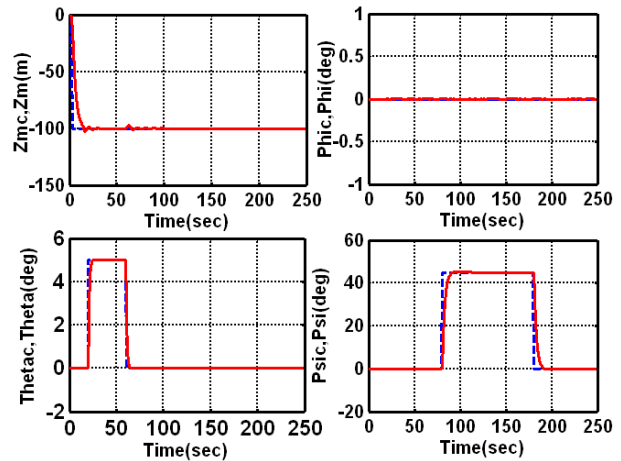

Fig.7 Time responses of Command Tracking.

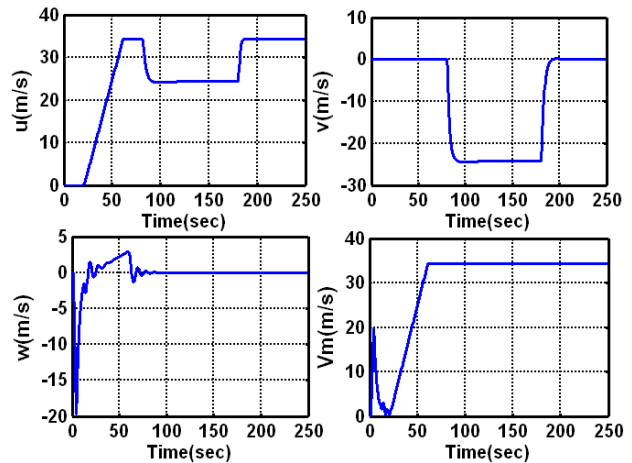

Fig.8 Time responses of Speeds.

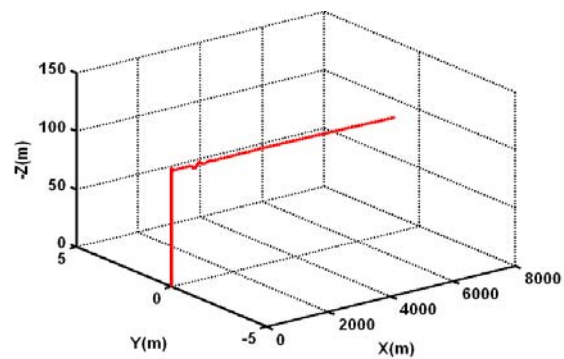

Fig.9. Time responses of flight locus.

Certainly, item (2) can be changed to non-zero speed control. It will give extra freedom for control than that of the conventional fix-fin flight vehicle. The speed control laws for X_B and Y_B axes are

$$Thetac = K_{ou}(u_c - u_f) \tag{14}$$

$$Phic = K_{ov}(v_c - v_f) \tag{15}$$

where u_c and v_c are speed commands, u_f and v_f are speed measurements. Naturally, one can get all speed control by disconnecting height control. Then relationship between body and inertia coordinated systems are given as below:

$$\begin{bmatrix} u_c \\ v_c \\ w_c \end{bmatrix} = \begin{bmatrix} \cos\theta\cos\psi & \sin\theta\sin\psi\cos\phi - \cos\theta\sin\psi & \cos\theta\sin\psi\cos\phi + \sin\theta\sin\psi \\ \cos\theta\sin\psi & \cos\theta\cos\psi + \sin\theta\sin\psi\sin\phi & \cos\theta\sin\psi\sin\phi - \sin\theta\cos\psi \\ -\sin\theta & \sin\theta\cos\phi & \cos\theta\cos\phi \end{bmatrix}^{-1} \begin{bmatrix} V_{xc} \\ V_{yc} \\ V_{zc} \end{bmatrix} \quad (16)$$

where (V_{xc}, V_{yc}, V_{zc}) are speeds on the inertial coordinated system; (u_c, v_c, w_c) are speeds on the body coordinated system. All speed control configuration can be used for E-guidance to approach target.

Fig.10, 11 and 12 show simulation verification for simulating the conventional fix-fin UAV. The speed controls $u_c=10\text{m/s}$, $v_c=0\text{m/s}$, $\theta=0.0\text{deg}$, and programmed altitude control. Simulation results shows they are similar to those of Bank-to-Turn (BTT) flight vehicle.

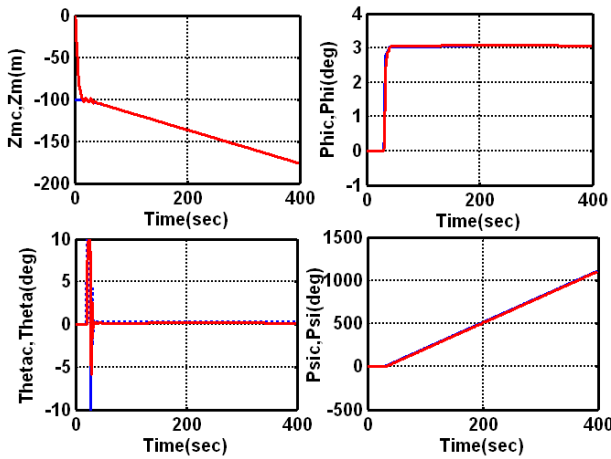

Fig.10. Time responses of Command Tracking.

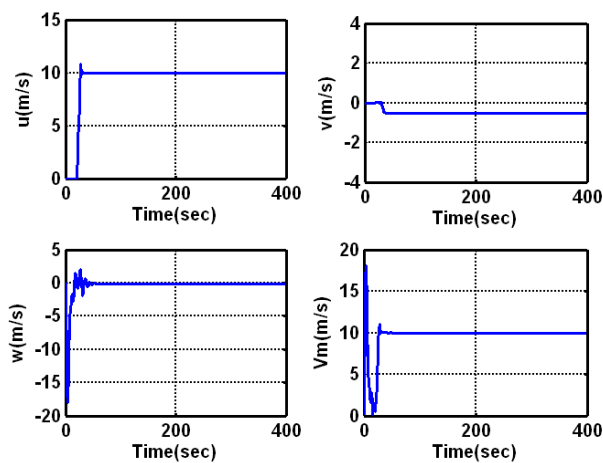

Fig.11. Time responses of Speeds.

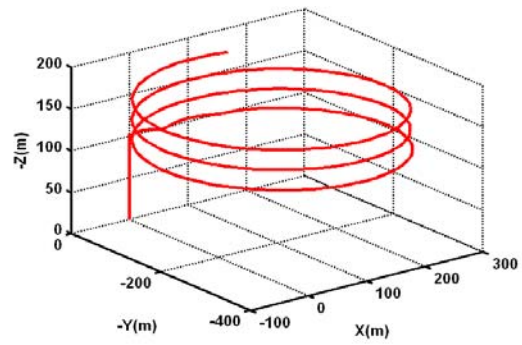

Fig.12. Time responses of flight locus.

3.4 Locus Tracking Laws

In this subsection, the new locus tracking law is developed. Locus tracking law is usually used in fix-fin flight vehicle. The conceptual design of the locus tracking laws is given below:

- (1) Speed Control for X_B -Axis: it is corresponding to forward propellant controls of the conventional fix-fin flight vehicle. The output control is the pitching angle command θ ;
- (2) Yawing angle tracking the flight path angle (ψ_L): the output control is command ψ
- (3) Speed Control for Y_B -axis: approaching the reference-tracking locus. The output control is speed command v_c .

The operating concept is shown in Fig.13. HL represents the distance between the Quadrotor and the tracking locus. The tracking laws are given below:

$$\psi = a \tan 2(Y_{i+1} - Y_i, X_{i+1}, X_i) \quad (17)$$

$$v_c = K_v (H_{LC} - H_L) \quad (18)$$

$HL=0$ represents the flight locus on the tracking locus; $HL=50$ represents the flight locus on the right of the tracking line with distance 50m. It can change the tracking locus sequentially for way point navigation(flight).

The conventional locus tracking laws are given below for comparison. They are

$$\Delta\psi = K_{th} (H_{LC} - H_L) \quad (19)$$

$$\text{Lim}(\Delta\psi, \pm 90^\circ) \quad (20)$$

$$\psi = a \tan 2(Y_{i+1} - Y_i, X_{i+1}, X_i) + \Delta\psi \quad (21)$$

$$v_c = 0.00 \quad (22)$$

The major difference between the tracking law for the Quadrotor and the conventional locus tracking laws[17,18] is the new tracking law described by Eqs.(17) and (18) can keep heading angle along the flight path angle; i.e., lateral approaching the tracking locus without changing heading. It will get

better imaging properties. The proposed new tracking law will be verified by digital simulations.

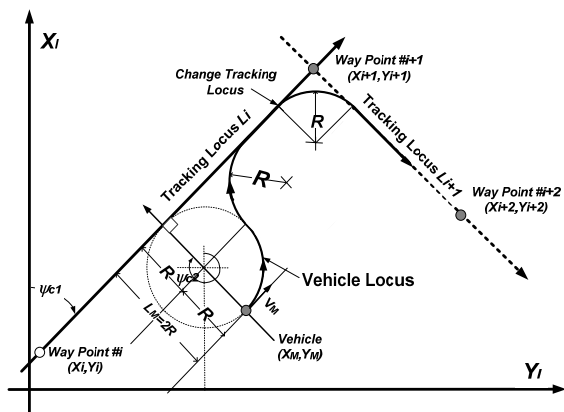

Fig.13 Concepts for locus Tracking.

keep the heading angle along the flight path angle.

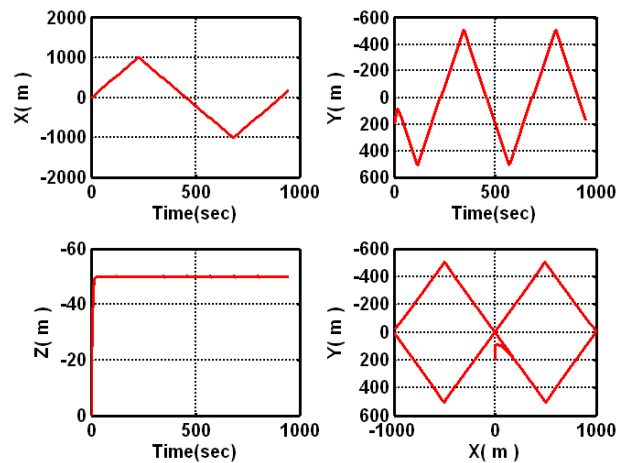

Fig.14. Flight Loci.

4. Simulation Verifications

Tracking locus law described by Eqs.(17) and (18), basic control laws described by Eqs.(10)-(13), and speed control laws described by Eqs.(14) and (15) in the above section are used and evaluated for, digital simulation verifications. Way points in simulation are given in Table 2.

Table 2: Way points used for simulation verification

Waypoint	X(m)	Y(m)	Z(m)
1	0	0	-50
2	500	500	-50
3	1000	0	-50
4	500	-500	-50
5	0	0	-50
6	-500	500	-50
7	-1000	0	-50
8	-500	-500	-50
9	0	0	-50

The simulation results for locus tracking are given in Fig.14. Fig.14 shows good performance for locus tracking. The tracking performance of the basic control system is shown in Fig.15. Fig.15(d) shows the controlled system give the yawing angle almost tracks the flight path angle. Fig.16 shows time responses of body-axis speeds and total speed. It shows that speed of the Quadrotor was decreased to very low; i.e., near suspending.

Comparisons with conventional locus tracking law are made and shown in Figs. 17 and 18. Fig.17 shows that the proposed method can track the locus faster. Fig.18 shows that the proposed method can

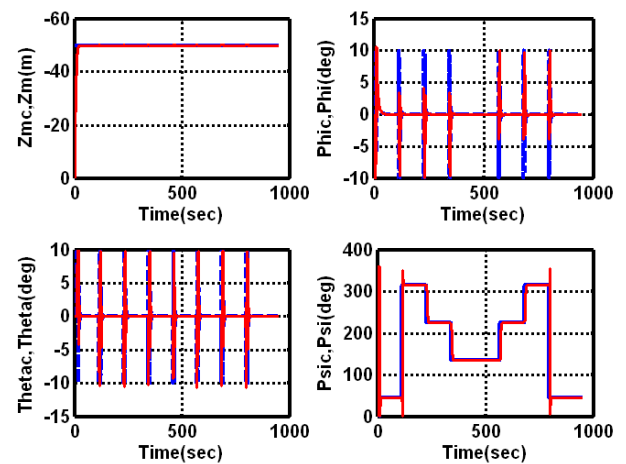

Fig.15. Time responses of basic control system.

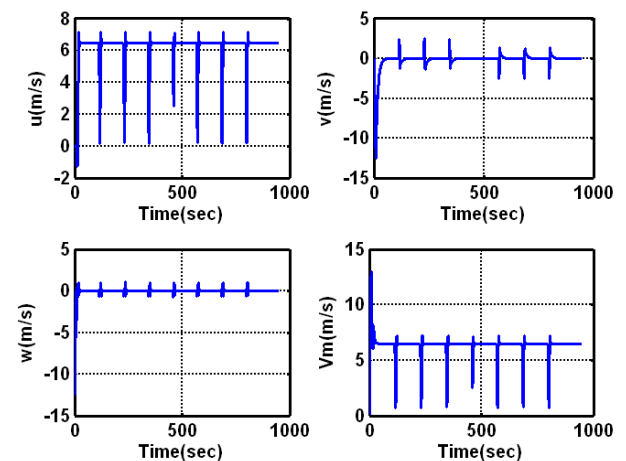

Fig.16. Time responses of Speeds.

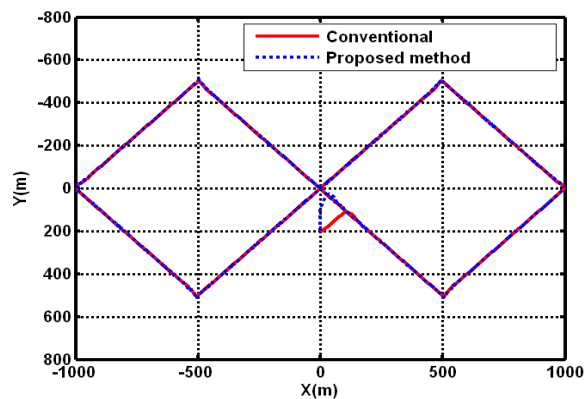

Fig.17. Comparisons of flight loci.

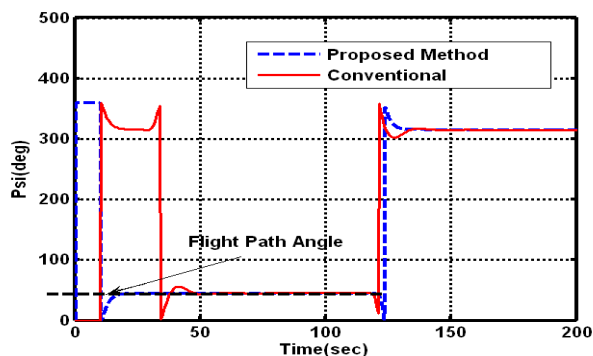

Fig.18. Comparison of yawing angles.

5. Conclusions

In this paper, new guidance and control laws have been proposed for a Quadrotor UAV. They were developed on the basic control system includes height control and attitude controls. The proposed method was verified by digital simulations. They give better performance than that of conventional guidance and control laws.

Reference

- [1] J. G. Leishman, The Breguet-Richet Quad Rotor Helicopter of 1907, <http://www.glue.umd.edu/leishman/> Aero, accessed Jan. 2009.
- [2] Y. Zhang et.al, The Attitude Control of the Four-rotor Unmanned Helicopter Based on Feedback Linearization Control, WSEAS Trans. on Systems, Vol.12, No.4, pp.229-239, 2014.
- [3] R. Mahony, E. Altug, and J. P. Ostrowski. Control of a Quadrotor Helicopter using Visual Feedback, Proceedings of 2002 IEEE Conference on Robotics and Automation, Washington DC, pp. 72-77, 2002.
- [4] H. Zhen, X. Qi and H. Dong, An Adaptive Block Backstepping Controller for Attitude Stabilization of a Quadrotor Helicopter, WSEAS Trans. On System and Control, Vol.8, No.2, pp.46-55, 2013
- [5] A. Tayebi, and S. McGilvray. Attitude Stabilization of a VTOL Quadrotor Aircraft, IEEE Transactions on Control Systems Technology, Vol. 14, pp. 562-571, 2006.
- [6] C. J. Tomlin, J. S. Jang, S. L. Waslander, and G. M. Ho_mann. Multi-Agent Quadrotor Testbed Control Design: Integral Sliding Mode vs. Reinforcement Learning, IEEE International Conference on Intelligent Robots and Systems, Alberta, Canada, pp. 468-473, 2005.
- [7] A. R. S. Bramwell, G. Done, and D. Balmford. Bramwells Helicopter Dynamics, 2nd ed., Butterworth Heinemann, Oxford, UK, 2001.
- [8] I. D. Cowling, O. A. Yakimenko, J. F. Whidborne and A. K. Cooke, A Prototype of an Autonomous Controller for a Quadrotor UAV, European Control Conference 2007 Kos, 2-5 July, Kos, Greece, 2007
- [9] S. Bouabdallah, A. Noth and R. Siegwart, PID vs LQ Control Techniques Applied to an Indoor Micro Quadrotor, Proc. of 2004 IEEE/RSJ Int. Conference on Intelligent Robots and Systems, September 28 - October 2, Sendai, Japan, 2004.
- [10] A. Hably and N. Marchand, Global Stabilization of a Four Rotor Helicopter with Bounded Inputs, Proc. of the 2007 IEEE/RSJ Int. Conference on Intelligent Robots and Systems, Oct 29 - Nov 2, San Diego, CA, USA, 2007
- [11] S. Bouabdallah and R. Siegwart, Full Control of a Quadrotor, Proc. Of the 2007 IEEE/RSJ Int. Conference on Intelligent Robots and Systems, Oct 29 - Nov 2, San Diego, CA, USA, 2007.
- [12] Tarek Madani and Abdelaziz Benallegue, Backstepping Control for a Quadrotor Helicopter, Proc. of the 2006 IEEE/RSJ Int. Conference on Intelligent Robots and Systems, October 9 - 15, Beijing, China, 2006.
- [13] E. Balasubramanian et.al, Dynamic Modeling and Control of Quad Rotor, Int. J. of Engineering and Technology, Vol.5, No.1, pp.63-69, 2013.
- [14] B. Erginer and E. Altug, Modeling and PD Control of a Quadrotor VTOL Vehicle, Proc/ of the 2007 IEEE Intelligent Vehicles Symposium, Istanbul, Turkey, June 13-15, 2007.
- [15] Y. Naidoo, R. Stopfprth and G. Bright, Quad-Rotor Unmanned Aerial Vehicle Helicopter Modelling & Control, Int. J. of Robotic Systems, Vol.8, No.4, pp.139-149, 2011.
- [16] K. T. Oner et.al, Dynamic Model and Control of a New Quadrotor Unmanned Aerial Vehicle with Tilt-Wing Mechanism, Int. J. of Engineering and Applied Sciences, Vol.5, No.2, pp.133-138, 2009.
- [17] H. J. Lin and T. S. Tsay, Modeling Identification and Simulation of Bank-to-turn Unmanned Aerial Vehicle, WSEAS Trans. on System, Vol.10, No.4, pp.91-103, 2011.
- [18] T. S. Tsay, Robust Altitude Guidance and Control Laws of Bank-to-turn Unmanned Aerial Vehicle, J. of Aeronautics Astronautics & Aviation, Series A, Vol.44, No.3, pp.183-192, 2012.
- [19] T. S. Tsay, Coupling Effects and decoupling for Supersonic Flight Vehicle, WSEAS Trans. on System and Control, Vol.7. No.3, pp.108-117, 2012.
- [20] P. Paunds et. al, Towards Dynamically- Favour- able Quad-Rotor Aerial Robots, In Proc. of Australasian Conference on Robotics and Automation, Canberra, Australia, 2004.