

A Convex Optimization Approach to Control Design for Switching Power Converters with Time Delays

Mohammad Karimi

Islamic Azad University, South Tehran Branch, Tehran, Iran

(E-mail: mkarimi71@gmail.com)

Abstract- In this paper a convex optimization approach to design a robust state feedback control is proposed for DC-DC converter systems with mixed delays. Based on the Lyapunov theory, some required sufficient conditions are established in terms of delay-dependent linear matrix inequalities for the stochastic stability and stabilization of the considered system using some free matrices. The desired control is derived based on a convex optimization method.

Key-Words: Robust control, DC-DC converter, Lyapunov function, delay, LMI

1. Introduction

The main task of DC-DC converters is the adaptation of the voltage and current levels between sources and loads while maintaining a low power loss in the conversion [1]-[2]. With the extensive use of DC-DC converters in different industry applications (e.g. power supplies for personal computers, DC-motor drive, telecommunications equipment, etc.), improving their performances becomes an interesting problem in recent years [1]-[7]. Recently, different converter circuits (buck converter, boost converter, buck-boost converter, Cuk converter, etc.) are known. According to each application purpose (increase or decrease the magnitude of the DC voltage and/or invert its polarity), the converter circuit was chosen. Among them, we consider here, the control of the basic Pulse-Width-Modulation (PWM) buck converters, but it could be easily adapted for other converters.

On the other hand, in recent years more attention has been devoted to the study of stochastic hybrid systems, where the so-called Markov jump systems. These systems represent an important class of stochastic systems that is popular in modeling practical systems like manufacturing systems, power systems, aerospace systems and networked control systems that may experience random abrupt changes in their structures and parameters [8]-[13]. Random parameter changes may result from random component failures, repairs or shut down, or abrupt changes of the operating point. Many such events can be modeled using a continuous time finite-state Markov chain, which leads to the hybrid description of system dynamics known as a Markov jump parameter system [14]; such a description will be

utilized in the paper. The state of a Markov jump parameter system is described by continuous range variables and also a random discrete event variable representing the regime of system operation. A great number of results on robust stability, stabilization, H_∞ control and filtering problems related to such systems have been reported in the literatures ([8], [9], [15]).

On another research front line, time delays for many dynamic systems have been much investigated; see for example [16]. Time-delayed systems represent a class of infinite-dimensional systems largely used to describe propagation and transport phenomena or population dynamics. Delay differential systems are assuming an increasingly important role in many disciplines like economic, mathematics, science, and engineering. For instance, in economic systems, delays appear in a natural way since decisions and effects are separated by some time interval. The delay effects on the stability of systems including delays in the state and/or input is a problem of recurring interest since the delay presence may induce complex behaviors for the schemes [16]-[17].

On the other hand, stability of neutral delay systems proves to be a more complex issue because the system involves the derivative of the delayed state. Especially, in the past few decades increased attention has been devoted to the problem of robust delay-independent stability or delay-dependent stability and stabilization via different approaches for linear neutral systems with delayed state and/or input and parameter uncertainties (see [18]-[19]). Among the past results on neutral delay systems, the LMI approach is an efficient method to solve many control problems such as stability analysis and

stabilization [20] and H_∞ control problems [21]-[24]. It is also worth citing that some appreciable works have been performed to design a guaranteed-cost (observer-based) control for the neutral system performance representation [25]-[27].

In this paper, we are concerned to develop a robust H_∞ control problem for Markovian switching systems with mixed discrete, neutral and distributed delays. The main merit of the proposed method is the fact that it provides a convex problem such the delay-dependent control gains can be found from the LMI formulations. Some required sufficient conditions are established in terms of LMIs combined with the Lyapunov-Krasovskii method for the existence of the desired control. Numerical examples are given to illustrate the use of our results for a DC-DC converter model.

Notation: The notations used throughout the paper are fairly standard. I and 0 represent identity matrix and zero matrix; the superscript ' T ' stands for matrix transposition. $\|\cdot\|$ refers to the Euclidean vector norm or the induced matrix 2-norm. $diag\{\dots\}$ represents a block diagonal matrix and the operator $sym(A)$ represents $A + A^T$. Let $\mathfrak{R}^+ = [0, \infty)$ and $\mathcal{E}\{\cdot\}$ denotes the expectation operator with respect to some probability measure \mathcal{P} . If $x(t)$ is a continuous \mathfrak{R}^n -valued stochastic process on $t \in [-\kappa, \infty)$, we let $x_t = \{x(t + \theta) : -\kappa \leq \theta \leq 0\}$ for $t \geq 0$ which is regarded as a $C([-\kappa, 0]; \mathfrak{R}^n)$ -valued stochastic process. The notation $P > 0$ means that P is real symmetric and positive definite; the symbol $*$ denotes the elements below the main diagonal of a symmetric block matrix.

2. Problem Description

Consider a class of uncertain time-delay systems with Markovian switching parameters and mixed neutral, discrete and distributed delays and norm-bounded time-varying uncertainties represented by

$$\begin{aligned} \dot{x}(t) - A_4(r(t))\dot{x}(t-d) &= (A_1(r(t)) + \Delta A_1(t, r(t)))x(t) \\ &+ (A_2(r(t)) + \Delta A_2(t, r(t)))x(t-h) + (A_3(r(t)) \\ &+ \Delta A_3(t, r(t))) \int_{t-\tau}^t x(s) ds + (A_5(r(t)) + \Delta A_4(t, r(t)))x(t-d) \\ &+ (B_1(r(t)) + \Delta B_1(t, r(t)))u(t) + (B_2(r(t)) + \Delta B_2(t, r(t)))w(t), \end{aligned} \quad (1a)$$

$$x(t) = \phi(t), \quad t \in [-\kappa, 0] \quad (1b)$$

$$r(t) = r_0, \quad t \in [-\kappa, 0] \quad (1c)$$

$$\begin{aligned} z(t) &= C(r(t))x(t) + C_d(r(t))x(t-d) + C_h(r(t))x(t-h) \\ &+ C_\tau(r(t)) \int_{t-\tau}^t x(s) ds + D(r(t))u(t), \end{aligned} \quad (1d)$$

where $x(t) \in \mathfrak{R}^n$, $u(t) \in \mathfrak{R}^m$, $w(t) \in L_2^s[0, \infty)$ and $z(t) \in \mathfrak{R}^z$ are state, input, disturbance and controlled

output, respectively. $A_i(r(t)), B_i(r(t)), C(r(t)), C_d(r(t)), C_h(r(t)), C_\tau(r(t))$ and $D(r(t))$ are matrix functions of the random jumping process $\{r(t)\}$. $\{r(t), t \geq 0\}$ is a right-continuous Markov process on the probability space which takes values in a finite space $S = \{1, 2, \dots, s\}$ with generator $\Pi = [\pi_{ij}] (i, j \in S)$ given by

$$P\{r(t + \Delta) = j | r(t) = i\} = \begin{cases} \pi_{ij}\Delta + o(\Delta), & \text{if } i \neq j \\ 1 + \pi_{ii}\Delta + o(\Delta), & \text{if } i = j \end{cases} \quad (2)$$

where $\Delta > 0$, $\lim_{\Delta \rightarrow 0} o(\Delta)/\Delta = 0$ and $\pi_{ij} \geq 0$, for $i \neq j$, is the transition rate from mode i at time t to mode j at time $t + \Delta$ and $\pi_{ii} = -\sum_{j=1, j \neq i}^s \pi_{ij}$. The time-varying

function $\phi(t)$ is continuous vector valued initial function and h, d and τ are constant time delays with $\kappa := \max\{h, d, \tau\}$. Moreover, the norm-bounded uncertainties are defined as follows:

$$\Delta A_i(t, r(t)) = H_1(r(t))\Delta(t, r(t))E_i(r(t)), \quad i = 1, 2, \dots, 4 \quad (3a)$$

$$\Delta B_j(t, r(t)) = H_1(r(t))\Delta(t, r(t))E_{4+j}(r(t)), \quad j = 1, 2 \quad (3b)$$

where $\Delta(t, r(t))$ is the uncertain time-varying matrix function of the random jumping process, which satisfies $\Delta^T(t, r(t))\Delta(t, r(t)) \leq I$ for $\forall t \geq 0; r(t) = i \in S$ and $E_i(r(t))$ and $H_1(r(t))$ are known real constant matrices of the random jumping process with appropriate dimensions.

Definition 1. Uncertain time-delay system (1) with Markovian switching parameter in (2) is said to be stochastically mean square stable if, when $u(t) = 0$, for any finite $\phi(t) \in \mathfrak{R}^n$ defined on $[-\kappa, 0]$, and $r_0 \in S$ the following condition is satisfied

$$\mathcal{E}\{\|x(t)\|^2\} \leq c \sup_{-\kappa \leq s \leq 0} \|x(s)\|^2, \quad t > 0$$

where $x(t)$ is the trajectory of the system state from initial system state $\phi(0)$ and initial mode r_0 , and c is a positive constant.

Definition 2. The H_∞ performance measure of the system (1) is defined as $J_\infty = \mathcal{E} \left(\int_0^\infty [z^T(t)z(t) - \gamma^2 w^T(t)w(t)] dt \right)$, where the positive scalar γ is given.

Assumption 1. The full state variable $x(t)$ is available for measurement.

In this paper, the author's attention will be focused on the design of the following robust mode-dependent delayed state feedback H_∞ control law,

$$u_i = K_i x(t) + K_{di} x(t-d) + K_{hi} x(t-h) + K_{\tau i} \int_{t-\tau}^t x(s) ds \quad (4)$$

where the matrices $K_i, K_{di}, K_{hi}, K_{\tau i}$ of the appropriate dimension is to be determined such that for any $r(t) = i \in S$ the resulting closed-loop system is stochastically stable and satisfies an H_∞ norm bound γ , i.e. $J_\infty < 0$.

3. Main Results

In this section, we first investigate both the stochastic stability and H_∞ performance of the system (1) with norm-bounded uncertainty parameters. A new delay-dependent stochastic stability condition by a discretization technique is proposed in Theorem 1. Then, we will show the procedure to design the controller gains $K_i, K_{di}, K_{hi}, K_{\tau i}$, which guarantee the resulting closed-loop system is stochastically stable and satisfies an H_∞ norm bound γ .

We choose a stochastic Lyapunov-Krasovskii functional candidate $V(\cdot, \cdot, \cdot, \cdot): \mathbb{R}^n \times \mathbb{R}^n \times \mathbb{R}^+ \times S \rightarrow \mathbb{R}^+$ as

$$V(x, x_t, t, i) = \sum_{i=1}^4 V_i(x, x_t, t, i) \quad (5)$$

where

$$V_1(x, x_t, t, i) = x(t)^T P_{1i} x(t) + 2x(t)^T \int_{-h}^0 Q(i) x(t+\xi) d\xi,$$

$$V_2(x, x_t, t, i) = \int_{-h}^t x(s)^T S x(s) ds + \int_{-h}^0 \int_{-h}^0 x(t+s)^T R x(t+\xi) ds d\xi,$$

$$V_3(x, x_t, t, i) = \int_{t-d}^t \dot{x}(s)^T U_1 \dot{x}(s) ds + \int_{-d}^0 x(t+\xi)^T H x(t+\xi) d\xi + \int_{-d}^0 \int_{-d}^0 x(t+s)^T T x(t+\xi) ds d\xi,$$

$$V_4(x, x_t, t, i) = \int_{t-\tau}^t \left[\int_s^t x(\theta)^T d\theta \right] U_2 \left[\int_s^t x(\theta) d\theta \right] ds + \int_{0}^{\tau} \int_{t-s}^t (\theta-t+s) x(\theta)^T U_2 x(\theta) d\theta ds$$

Theorem 1. The time-delay system (1) with Markovian switching parameters in (2) and without the norm-bounded uncertainties in (3) is stochastically mean square stable with an H_∞ performance level $\gamma > 0$, if there exist some matrices $P_{2i}, P_{3i}, H, Q_i, R = R^T, T = T^T$, and

positive definite matrices P_{1i}, U_1, U_2, S ($l = 1, 2, \dots, s$) satisfying the following LMIs

$$\begin{bmatrix} P_{1i} & Q_i \\ * & R+S \end{bmatrix} > 0, \quad (6a)$$

$$\Xi_{ei} = \begin{bmatrix} \Sigma_{1i} + \text{diag}\{C_i^T C_i, 0\} & \begin{bmatrix} P_{2i}^T A_{2i} - Q_i + C_i^T C_{hi} \\ P_{3i}^T A_{2i} \end{bmatrix} & \begin{bmatrix} \Sigma_{2i} \\ P_{3i}^T A_{5i} \end{bmatrix} \\ * & -S + C_{hi}^T C_{hi} & 0 \\ * & * & \Sigma_{3i} \\ * & * & * \\ * & * & * \\ * & * & * \\ \begin{bmatrix} (P_{2i}^T - P_{1i})A_{4i} \\ P_{3i}^T A_{4i} \\ 0 \\ A_{4i}^T P_{1i} A_{4i} \\ -U_1 \\ * \\ * \end{bmatrix} & \begin{bmatrix} P_{2i}^T A_{3i} + C_i^T C_{ti} \\ P_{3i}^T A_{3i} \\ 0 \\ 0 \\ 0 \\ C_{ti}^T C_{ti} - U_2 \\ * \end{bmatrix} & \begin{bmatrix} P_{2i}^T B_{2i} \\ P_{3i}^T B_{2i} \\ 0 \\ 0 \\ 0 \\ 0 \\ -\gamma^2 I \end{bmatrix} \end{bmatrix} < 0 \quad (6b)$$

where $P_i = \begin{bmatrix} P_{1i} & 0 \\ P_{2i} & P_{3i} \end{bmatrix}$ and

$$\Sigma_{1i} = \text{sym} \left(P_i^T \begin{bmatrix} 0 & I \\ A_{1i} & -I \end{bmatrix} \right) + \text{diag}\{ \sum_{j=1}^s \pi_{ij} P_{1j} + \text{sym}(Q_i) + S + H + \tau^2 U_2, U_1 \},$$

$$\Sigma_{2i} = P_{2i}^T A_{5i} + C_i^T C_{di} + \left(\sum_{j=1}^s \pi_{ij} P_{1j} - Q_{i0} \right) A_{4i},$$

$$\Sigma_{3i} = C_{di}^T C_{di} - H + \sum_{j=1}^s A_{4i}^T \pi_{ij} P_{1j} A_{4i},$$

Proof. See [28].

Remark 1. Note that the matrix

$$P_i = \begin{bmatrix} P_{1i} & 0 \\ P_{2i} & P_{3i} \end{bmatrix}$$

(or, equivalently, the matrix P_{3i}) is non-singular due to the fact that the only matrix which can be negative definite in the first block on the diagonal of LMI (6b) is $\Sigma_{1i} < 0$.

Remark 2. If the switching modes are not considered, i.e. $S = \{1\}$, the jump linear system is simplified into a general linear system with nonlinearities and time delays. Then it is easy to conclude a criterion from Theorem 1, which can be used to determine the stability of such a system.

In the following, we present a condition for the stability of the time-delay system (1) with Markovian switching parameters in (2) and norm-bounded uncertainties in (3).

Theorem 2. Under Assumption 1, a state feedback controller given in the form (4) exists such that the time-delay system (1) with Markovian switching parameters in (2) is stochastically stable with an H_∞ performance level $\gamma > 0$, if there exist some scalars δ_i, μ_i , matrices $\bar{P}_{2i}, \bar{H}, \bar{Q}_l, \bar{R} = \bar{R}^T, \bar{T} = \bar{T}^T, L_i, L_{di}, L_{hi}, L_{\tau i}$, and positive definite matrices $\tilde{P}_{1i}, \tilde{U}_1, \tilde{U}_2, \tilde{S}$ ($l = 1, 2, \dots, s$), satisfying the following LMIs

$$\begin{bmatrix} \tilde{P}_{1i} & \hat{Q}_i \\ * & \hat{R} + \hat{S} \end{bmatrix} > 0, \quad (7a)$$

$$\begin{bmatrix} \hat{\Xi}_{ei} & \hat{\Gamma}_{di} & \mu \hat{\Gamma}_{ei} \\ * & -\mu_i I & 0 \\ * & * & -\mu_i I \end{bmatrix} < 0 \quad (7b)$$

where $\hat{\Gamma}_{di} = [H_{1i}^T, \delta_i H_{1i}^T, 0, \dots, 0]^T$, $\hat{\Gamma}_{ei} = [E_{1i} + E_{5i}L_i, 0, E_{2i} + E_{5i}L_{hi}, E_{4i} + E_{5i}L_{di}, 0, E_{3i} + E_{5i}L_{\tau i}, E_{6i}\bar{P}_{2i}]$ and $\hat{\Xi}_{ei} =$

$$\begin{bmatrix} \Lambda_{11} & \Lambda_{12} & \Lambda_{13} & \Lambda_{14} & \Lambda_{15} & \Lambda_{16} & \Lambda_{17} \\ * & -\tilde{S}_N & 0 & 0 & 0 & 0 & \Lambda_{27} \\ * & * & \Lambda_{33} & \varpi_i^2 \tilde{P}_{1i} & 0 & 0 & \Lambda_{37} \\ * & * & * & -\tilde{U}_1 & 0 & 0 & 0 \\ * & * & * & * & -\tilde{U}_2 & 0 & \Lambda_{57} \\ * & * & * & * & * & -\gamma^2 I & 0 \\ * & * & * & * & * & * & -I \end{bmatrix},$$

where

$$\begin{aligned} \Lambda_{11} &= \text{sym} \left(\begin{bmatrix} A_{1i}\bar{P}_{2i} + B_{1i}L_i & \bar{P}_{1i} - \bar{P}_{2i} \\ \delta_i (A_{1i}\bar{P}_{2i} + B_{1i}L_i) & -\delta_i \bar{P}_{2i} \end{bmatrix} \right) \\ &\quad + \text{diag} \left\{ \sum_{j=1}^s \pi_{ij} \tilde{P}_{1j} + \text{sym}(\bar{Q}_i) \right. \\ &\quad \left. + \tilde{S} + \bar{H} + \tau^2 \tilde{U}_2, \tilde{U}_1 \right\}, \\ \Lambda_{12} &= \begin{bmatrix} A_{2i}\bar{P}_{2i} + B_{1i}L_{hi} - \bar{Q}_i \\ -\delta_i (A_{2i}\bar{P}_{2i} + B_{1i}L_{hi}) \end{bmatrix}, \Lambda_{13} = \\ &\begin{bmatrix} A_{5i}\bar{P}_{2i} + B_{1i}L_{di} + \varpi_i (\sum_{j=1}^s \pi_{ij} \tilde{P}_{1j} - \bar{Q}_i) \\ -\delta_i A_{5i}\bar{P}_{2i} + B_{1i}L_{di} + \varpi_i (\sum_{j=1}^s \pi_{ij} \tilde{P}_{1j} - \bar{Q}_i) \end{bmatrix}, \\ \Lambda_{14} &= \begin{bmatrix} A_{4i}\bar{P}_{2i} - \varpi_i \tilde{P}_{1i} \\ \delta_i A_{4i}\bar{P}_{2i} \end{bmatrix}, \Lambda_{15} = \\ &\begin{bmatrix} A_{3i}\bar{P}_{2i} + B_{1i}L_{\tau i} \\ -\delta_i (A_{3i}\bar{P}_{2i} + B_{1i}L_{\tau i}) \end{bmatrix}, \Lambda_{16} = \begin{bmatrix} B_{2i}\bar{P}_{2i} \\ \delta_i B_{2i}\bar{P}_{2i} \end{bmatrix}, \Lambda_{17} = \\ &\begin{bmatrix} C_i^T \bar{P}_{2i} + D_i^T L_i \\ 0 \end{bmatrix}, \end{aligned}$$

and $\Lambda_{33} = -\tilde{H} + \lambda_{\max}^2(A_{4i}) \sum_{j=1}^s \pi_{ij} \tilde{P}_{1j}$, $\Lambda_{27} = D_i^T L_{hi}$, $\Lambda_{37} = D_i^T L_{di}$, $\Lambda_{57} = D_i^T L_{\tau i}$ with $\varpi_i := \lambda_{\max}(A_{4i})$. Moreover, the controller gains in (4) can

be designed as $K_i = L_i \bar{P}_{2i}^{-1}, K_{di} = L_{di} \bar{P}_{2i}^{-1}, K_{hi} = L_{hi} \bar{P}_{2i}^{-1}, K_{\tau i} = L_{\tau i} \bar{P}_{2i}^{-1}$.

Proof. See [28].

Remark 3. By setting $\eta = \gamma^2$ and minimizing η subject to LMIs (26), we can obtain the optimal H_∞ performance level γ^* (by $\gamma^* = \sqrt{\eta}$) and the corresponding control gains as well.

4. DC-DC converters

There are three kinds of switching mode DC-DC converters, buck, boost and buck-boost. The buck mode is used to reduce output voltage, whilst the boost mode can increase the output voltage. In the buck-boost mode, the output voltage can be maintained either higher or lower than the source but in the opposite polarity. The simplest forms of these converters are schematically represented in Figure 1. These converters consist of the same components, an inductor, L, a capacitor, C and a switch, which has two states $u = 1$ and $u = 0$. All converters connect to a DC power source with a voltage (unregulated), V_{in} and provide a regulated voltage, v_o to the load resistor, R by controlling the state of the switch. In some situations, the load also could be inductive, for example a DC motor, or approximately, a current load, for example in a cascade configuration. For simplicity, here, only current and resistive loads are to be considered.

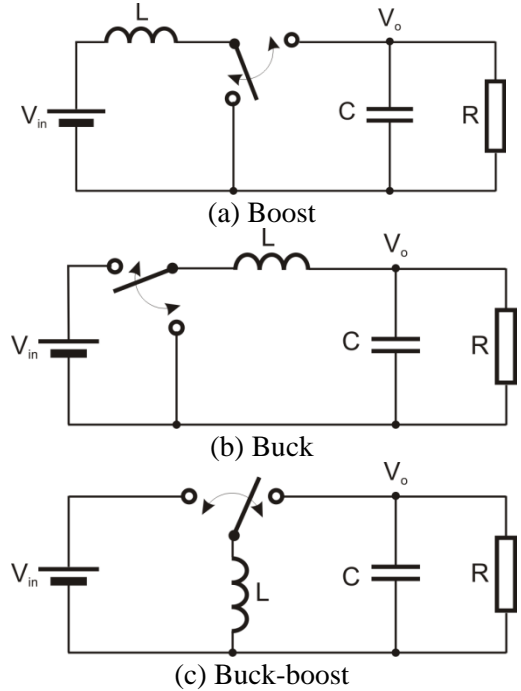

Figure 1. Switching-mode DC-DC converters: (a) buck, (b) boost and (c) buck-boost.

5. Averaged model of Basic PWM buck converter

Figure 1 shows the basic circuit of the nonlinear PWM buck converter proposed in [3]-[4] with an external disturbance $i_{load}(t)$ as proposed in [1]-[2]. R_m is the on-state resistance of the MOSFET transistor, R_L is the winding resistance of inductor, V_d is the threshold voltage of the diode and R_c is the equivalent series resistance of the filter capacitor. By applying the Kirchhoff's voltage law (KVL) and Kirchhoff's current law (KCL) in on-state of the MOSFET transistor case, we obtain [29]:

$$\begin{bmatrix} \dot{i}_1(t) \\ \dot{v}_c(t) \end{bmatrix} + E \begin{bmatrix} i_1(t-d) \\ v_c(t-d) \end{bmatrix} = \begin{bmatrix} \frac{-1}{L}(R_1 + R\|R_c) & \frac{-R\|R_c}{LR_c} \\ \frac{R\|R_c}{CR_c} & \frac{-R\|R_c}{CRR_c} \end{bmatrix} \begin{bmatrix} i_1(t) \\ v_c(t) \end{bmatrix} + \begin{bmatrix} \frac{1}{L}(V_{in} + R_m i_1(t)) \\ 0 \end{bmatrix} + \begin{bmatrix} \frac{R\|R_c}{L} \\ \frac{-R\|R_c}{CR_c} \end{bmatrix} i_{load}(t) \tag{8}$$

where $E = \begin{bmatrix} c_1 & 0 \\ 0 & c_2 \end{bmatrix}$ and $R\|R_c = \frac{RR_c}{R + R_c}$.

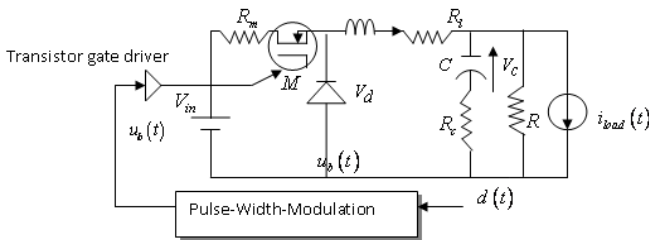

Figure 2. Schematic of a basic PWM buck converter.

Now, in off-state of the MOSFET transistor case and by applying of KVL and KCL, we get:

$$\begin{bmatrix} \dot{i}_1(t) \\ \dot{v}_c(t) \end{bmatrix} + E \begin{bmatrix} i_1(t-d) \\ v_c(t-d) \end{bmatrix} = \begin{bmatrix} \frac{-1}{L}(R_1 + R\|R_c) & \frac{-R\|R_c}{LR_c} \\ \frac{R\|R_c}{CR_c} & \frac{-R\|R_c}{CRR_c} \end{bmatrix} \begin{bmatrix} i_1(t) \\ v_c(t) \end{bmatrix} + \begin{bmatrix} \frac{-V_d}{L} \\ 0 \end{bmatrix} + \begin{bmatrix} \frac{R\|R_c}{L} \\ \frac{-R\|R_c}{CR_c} \end{bmatrix} i_{load}(t) \tag{9}$$

Using Averaging Method of on One Time Scale Discontinuous system (AM-OTS-Ds) [30], the

global dynamical behavior of the DC-DC converter is modeled as:

$$\begin{bmatrix} \dot{i}_1(t) \\ \dot{v}_c(t) \end{bmatrix} + E \begin{bmatrix} i_1(t-d) \\ v_c(t-d) \end{bmatrix} = \begin{bmatrix} \frac{-1}{L}(R_1 + R\|R_c) & \frac{-R\|R_c}{LR_c} \\ \frac{R\|R_c}{CR_c} & \frac{-R\|R_c}{CRR_c} \end{bmatrix} \begin{bmatrix} i_1(t) \\ v_c(t) \end{bmatrix} + \begin{bmatrix} \frac{-V_d}{L} \\ 0 \end{bmatrix} + \begin{bmatrix} V_{in} + V_d + R_m i_1(t) \\ 0 \end{bmatrix} d(t) + \begin{bmatrix} \frac{R\|R_c}{L} \\ \frac{-R\|R_c}{CR_c} \end{bmatrix} i_{load}(t) \tag{10}$$

where $d(t)$ is the duty cycle.

6. Simulation results

In this section, with the aid of MATLAB LMI Toolbox [31], we use the averaged model of Basic PWM buck converter to illustrate the effectiveness and advantage of our design method. In this simulation, the PWM frequency equals to 1 kHz. The simulation parameters used in this work are as follows [3]:

$R = 6 \Omega$, $R_l = 48.5 m\Omega$, $R_c = 0.16 \Omega$, $R_m = 0.27 \Omega$, $V_{in} = 30V$, $L = 98.58 mH$, $C = 202.5 \mu F$,

$I_{lmin} = 0A$, $I_{lmax} = 10A$

with the input current $i_{load} = 0.25 \sin(1000t)$. The DC-DC converter parameters are switching between two modes, i.e., 1.0 and 1.2 nominal values, under the following Markovian transition matrix (8a)

$$\pi = \begin{bmatrix} -0.6 & 0.6 \\ 0.2 & -0.2 \end{bmatrix}$$

The optimization problem described in (7) is solved for initial condition $x_0 = 0$, $h = 15 ms$ and $c = 0.3$. Responses of the output voltage of PWM buck converter and the inductance current of PWM buck converter are, respectively, plotted in Fig. 3 and Fig. 4.

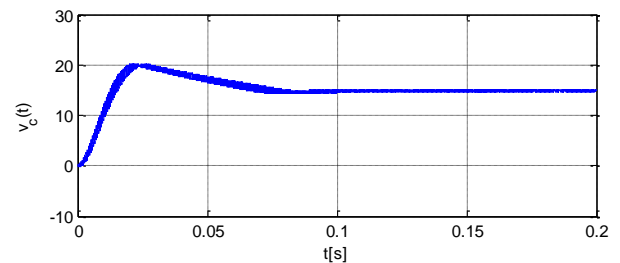

Figure 3. Response of the output voltage of PWM buck converter

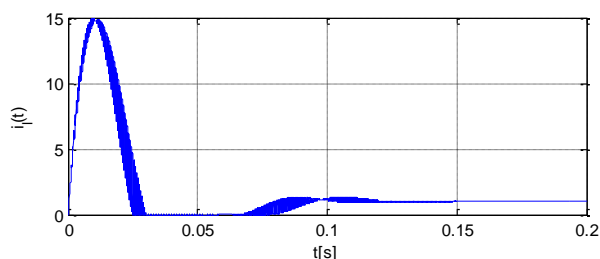

Figure 4. Response of the inductance current of PWM buck converter.

7. Conclusion

The problem of robust state feedback H_∞ control was proposed for a class of Markovian switching systems with mixed discrete, neutral and distributed delays. Some required sufficient conditions were derived in terms of delay-dependent LMIs using some free matrices and the Lyapunov-Krasovskii functional theory. The desired control is derived based on a convex optimization method. Numerical examples were given to illustrate the use of our results for a DC-DC converter model.

References

- [1] C.Olalla, R. Leyva, A. El Aroudi, I. Queinnec, S. Tarbouriech, Control of DC-DC Converters Converters with Saturated Inputs, IEEE Conf. on Industrial Electronics, IECON'09, Porto, 2009.
- [2] C. Olalla, I. Queinnec, R. Leyva, A. ElAroudi, Robust optimal control of bilinear DC-DC converters, Control Eng. Practice, In Press, 2011.
- [3] Y. Li, Z. Ji, T-S Modeling, Simulation and Control of the Buck onverter, 5th Inter. Conference on Fuzzy Systems and Knowledge Discovery, 18-20 Oct. 2008, Schandong, China, pp. 663-667.
- [4] K. Y. Lian, J.J. Liou, LMI-based integral fuzzy control of DC-DC converters, IEEE transaction on Fuzzy System, 14(2006), 71-80.
- [5] D. Cortés, Jq. Alvarez, Ja. Alvarez-Gallegos, Feedforward and feedback robust control of the buck converter, 15th World IFAC Congress, Barcelona, Spain, (2002).
- [6] I. Gadoura, T. Suntio, K. Zenger, Roubust control design for paralleled DC/Dc converters with current sharing, 15th World IFAC Congress, Spain (2002).
- [7] D. Alejo, P. Maussion, J. Fauche1, Multiple model control of a Buck DC/DC converter, Mathematics and Computers in Simulation 63 (2003) 249-260.
- [8] Boukas, E.K., and Benzaouia, A.. Stability of discrete-time linear systems with Markovian jumping parameters and constrained control. *IEEE Transactions on Automatic Control*, 47(3), 516-521, 2002.
- [9] Shi, P., and Boukas, E.K.. H_∞ control for Markovian jumping linear systems with parametric uncertainty. *Journal of Optimization Theory and Applications*, 95(1), 75-99, 1997.
- [10] Shi, P., Boukas, E. K., and Agarwal, K.. Kalman filtering for continuous-time uncertain systems with Markovian jumping parameters. *IEEE Transactions on Automatic Control*, 44(8), 1592-1597, 1999.
- [11] Shi, P., Boukas, E. K., and Agarwal, K.. Control of Markovian jump discrete-time systems with norm bounded uncertainty and unknown delay. *IEEE Trans. on Automatic Control*, 44(11), 2139-2144, 1999.
- [12] Shi, P., Xia, Y., Liu, G. P., and Rees, D.. On designing of sliding-mode control for stochastic jump systems. *IEEE Transactions on Automatic Control*, 51(1), 97-103, 2006.
- [13] Wang Z., Lam J., Liu X., 'Exponential filtering for uncertain Markovian jump time-delay systems with nonlinear disturbances' *IEEE Trans. Circuits and Systems, II: Express Briefs*, 51(5), 262-268, 2004.
- [14] Mariton, M.. *Jump linear systems in automatic control*. New York: Marcel Dekker Inc, 1990.
- [15] Saif A.W., Mahmoud M.S. and Shi Y., 'A parameterized delay-dependent control of switched discrete-time systems with time-delay,' *Int. J. Innov. Comput., Information and Control*, 5(9), 2893-2906, 2009.
- [16] Niculescu S. I., *Delay Effects on Stability: A Robust Control Approach* (Berlin: Springer), 2001.
- [17] Gu K., Kharitonov V.L., and Chen J., '*Stability of time-delay systems*' Birkhauser, Boston, 2003, ISBN 0-8176-4212-9.
- [18] Ivansecu, D., Niculescu S.I., Dugard L., Dion M. and Verriest E.I., 'On delay-dependent stability of linear neutral systems', *Automatica*, 39, 255-261, 2003.
- [19] Lam, J., Gao, H., and Wang, C., ' H_∞ model reduction of linear systems with distributed delay.' *IEE Proc. Control Theory Appl.*, 152(6), 662-674, 2005.
- [20] Fridman, E., 'New Lyapunov-Krasovskii functionals for stability of linear retarded and neutral type systems.' *Systems and Control Letters*, 43, 309-319, 2001.
- [21] Fridman, E., and Shaked, U., 'Delay-dependent stability and H_∞ control: constant and time-

- varying delays.' *International Journal of Control*, 76, 48-60, 2003.
- [22] Gao, H., and Wang, C., 'Comments and further results on 'A descriptor system approach to H_∞ control of linear time-delay systems.' *IEEE Transactions on Automatic control*, 48, 520-525, 2003.
- [23] Zhao Y., Gao H., Lam J. and Du B., Stability and stabilization of delayed T-S fuzzy systems: A delay partitioning approach. *IEEE Trans. on Fuzzy Systems*, 17(4), 750-762, 2009.
- [24] Karimi H.R. and Gao H., 'New delay-dependent exponential H_∞ synchronization for uncertain neural networks with mixed time-delays' *IEEE Trans. on Systems, Man and Cybernetics-B*, 40(1), 173-185, 2010.
- [25] Chen, B., Lam, J., and Xu, S., 'Memory state feedback guaranteed cost control for neutral systems' *Int. J. Innovative Computing, Information and Control*, 2(2), 293-303, 2006.
- [26] Park J.H., 'Guaranteed cost stabilization of neutral differential systems with parametric uncertainty' *J. Computational and Applied mathematics*, 151, 371-382, 2003.
- [27] Lien, C.H., 'Guaranteed cost observer-based controls for a class of uncertain neutral time-delay systems.' *J. Optimization Theory and Applications*, 126(1), 137-156, 2005.
- [28] H.R. Karimi, Robust Delay-Dependent H_∞ Control of Uncertain Markovian Jump Systems with Mixed Neutral, Discrete and Distributed Time-Delays, *IEEE Trans. Circuits and Systems I*, 58(8), 1910-1923, 2011.
- [29] J. Sun, H. Grotstollen, Averaged modelling of switching power converters: Reformulation and theoretical basis, *Power electronics specialists conf.*, 29-03 jul 1992, Taledo, Spain, pp. 1165-1172.
- [30] Bellen A., Guglielmi N., and Ruehli A.E., 'Methods for linear systems of circuit delay differential equations of neutral type' *IEEE Trans. on Circuits and Systems-I*, 46(1), 212-216, 1999.
- [31] P. Gahinet, A. Nemirovsky, A.J. Laub, and M. Chilali, '*LMI control Toolbox: For use with Matlab.*' Natick, MA: The MATH Works, Inc., 1995.