

A comparative analysis of electric vehicles charging devices on distribution network

GERGANA VACHEVA¹, HRISTIYAN KANCHEV¹, NIKOLAY HINOV¹ and RAD STANEV²

Department of Power Electronic¹

Electrical Power Engineering Department²

Technical University of Sofia

Sofia, 1000, bul. Kl. Ohridsky 8

BULGARIA

gergana_vacheva@tu-sofia.bg, hkanchev@tu-sofia.bg, hinov@tu-sofia.bg, rstanev@tu-sofia.bg

Abstract: - This paper presents a comparative analysis of electric vehicles (EV) charging devices impact on microgrid. Increased load variation may create a need for upgrades in grid infrastructure. For this purpose a set of typical load profiles of EV charging modes is studied and presented. A software implementation and a 24h case study of low voltage distribution network with EV charging devices is presented in order to illustrate the approach and the impacts of EV charging on the grid. Through this research the EV charging devices may become a flexible load that can help prevent load variations and load peaks on distributed network.

Key-Words: - energy flows, electric vehicle, battery storage devices, smart micro grids, state of charge

1 Introduction

In order to preserve the environment through a reduction of harmful emissions, in our days the usage of the electric vehicles is growing. And thus it is established that their charge stations are a major challenge for low voltage distribution networks stability [1, 2]. The simultaneous operation of multiple EV charge stations represents a significant load for which most of the distribution grids are not designed for. For this reason, the influence of various EV charge profiles on microgrids is a topic of interest [3]. In the case of unidirectional charging devices (the ones that only consume power and do not provide grid support) the charging process can be represented as a distributed load to reduce grid congestion. The growing number of EV leads to a considerable increase of the load in distribution networks and difficulties in managing overloads and dispatching of the grid.

A comparative analysis for charging stations control in order to decrease peak loads and optimize energy flows in distribution networks is presented in this paper. Objective of the proposed solution is the implementation of a schedule which supports the grid at peak load periods using the energy storage elements of electric vehicles. This can be done by using bidirectional charging devices for EV – in this way they can consume energy in periods of excess production and supply it to the local grid afterwards.

As a result, balancing of the daily energy flows can be achieved.

2 Description of the studied microgrid

Recently a variety of techniques and methodologies for power system analysis exist. Even in a system with multiple branches, the classical analysis of energy flows can provide a precise solution to the given problem, at the cost of increased computational time. Nevertheless limitations based on the availability of the electric vehicles are imposed – their usage is based on different repetitive patterns in weekdays and the weekend.

In the current paper an approach using variable nonlinear algebraic equations for dynamic time domain analysis of the charge of the electric vehicles is presented. On Fig.1 is shown the studied system: a three-phase 0,4 kV distribution network with 21 nodes located in a small village near the city of Sofia [4]. The grid is equally distributed, the loads are considered symmetrical in all phases and with power factor correction (predominantly active load) therefore the compensation of reactive power is not taken into consideration in this study. The minimal and the maximal load of the system without EV charging are respectively $P_{min} = 33,2$ kW and $P_{max} = 110,8$ kW.

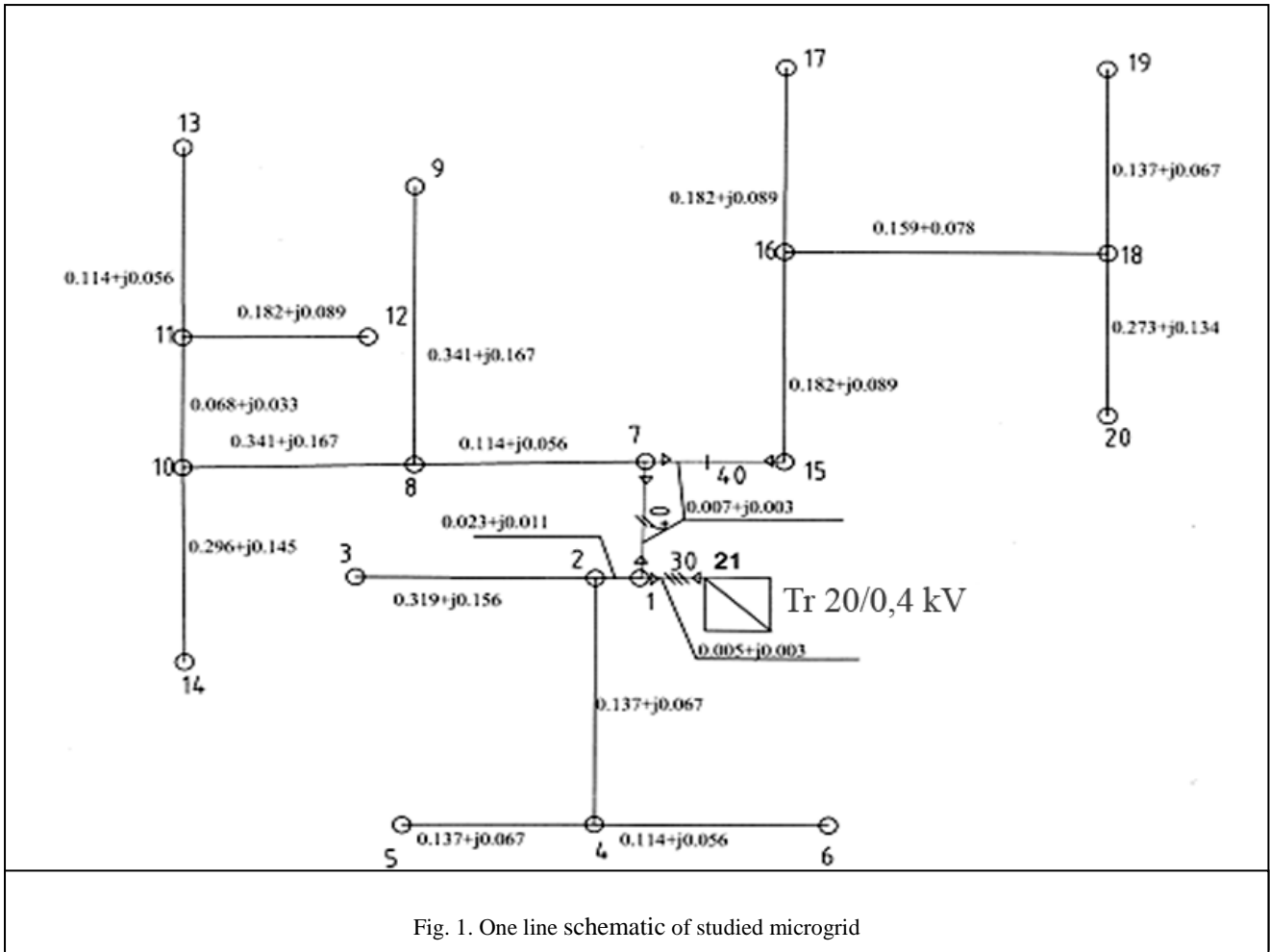

Fig. 1. One line schematic of studied microgrid

At node 10 and 18 of the grid are connected two photovoltaic (PV) arrays: one with a peak power $PG1 = 30$ kW connected at node 10 and the second is connected at node 18 and has a peak power $PG2 = 50$ kW.

The values used for analysis of the electrical system are the magnitudes and phase angles of the voltages, the active and reactive powers. The following equations describe the state of each node in the studied microgrid [3].

$$P_k = \sum_{m \in k} V_k V_m (G_{km} \cos \theta_{km} + B_{km} \sin \theta_{km}) \quad (1)$$

$$Q_k = \sum_{m \in k} V_k V_m (G_{km} \sin \theta_{km} - B_{km} \cos \theta_{km}) \quad (2)$$

Where

- P_k is the active power in node k ;
- Q_k is the reactive power in node k ;
- V_k is the magnitude of the voltage in node k ;

- V_m is the magnitude of the voltage in node m ;

$$\dot{Y}_{km} = G_{km} + jB_{km} \quad (3)$$

is element k, m from the bus admittance matrix;

- θ_k voltage angle at node k ;
- θ_m voltage angle at node m ;

and $\theta_{km} = \theta_k - \theta_m$

2.1 Types of electric vehicles present in the system

For this study are considered four common models of electric vehicles: Mitsubishi i-MiEV family, Nissan Leaf, Tesla Model S and BMW i3. Those models were also chosen because of the fact that their characteristics and charging profiles (in normal charge and fast charge modes) are accessible from numerous sources including documentation provided by the producers. In future, the number EV in urban areas is expected to increase, each model having different charge profile, therefore the impact

of an increased number of different models and charging profiles can be examined.

2.2 Profiles of EV charging

At the following figures (fig. 2 to fig. 7) are presented the characteristic charging profiles of the considered vehicles in different charge modes and by different values of the initial State Of Charge (SoC) - the maximum charging power is given as a function of the batteries SoC. From those characteristics and the daily grid congestion and PV production profiles, the optimal time for full charge of the vehicles is determined.

The charging stations have a significant impact on the time and mode of charging the EV batteries. The charging devices should provide relatively high instantaneous power, low cost and high efficiency of the power conversion. A classification of charging devices storage station can be made by the following parameters:

- location of the storage devices: on-board and off-board charger;
- direction of the energy flows: unidirectional and bidirectional charging devices;
- mode of charge: normal and fast (high-power) charge.

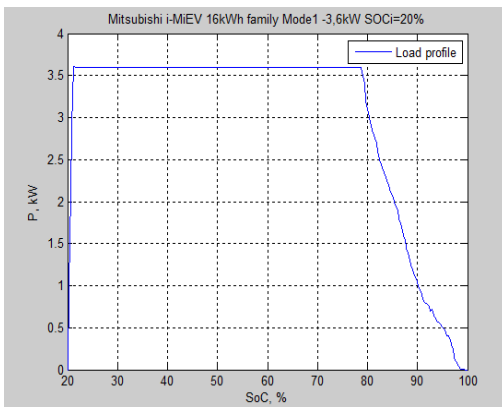

Fig. 2. State of charge profile of Mitsubishi i-Miev - 3,6 kW

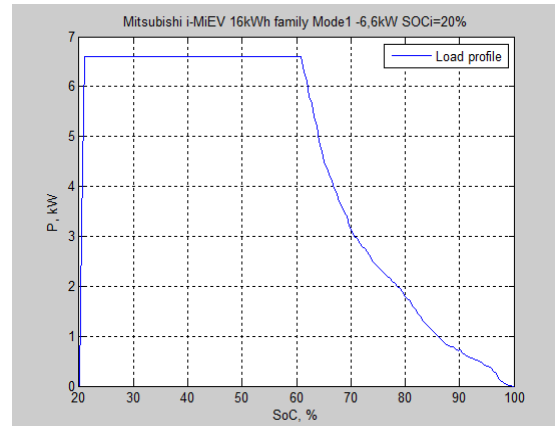

Fig. 3. State of charge profile of Mitsubishi i-Miev - 6,6 kW (fast charge)

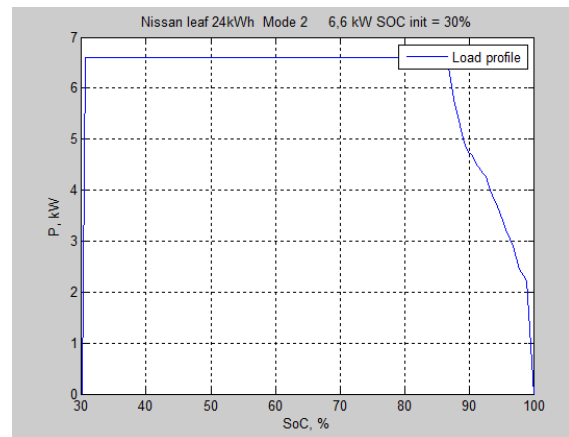

Fig. 4. State of charge of Nissan leaf - 6,6 kW (fast charge)

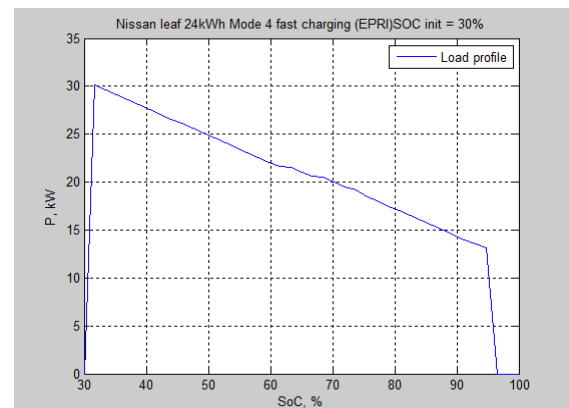

Fig. 5. State of charge of Nissan leaf - 24 kW (fast charge)

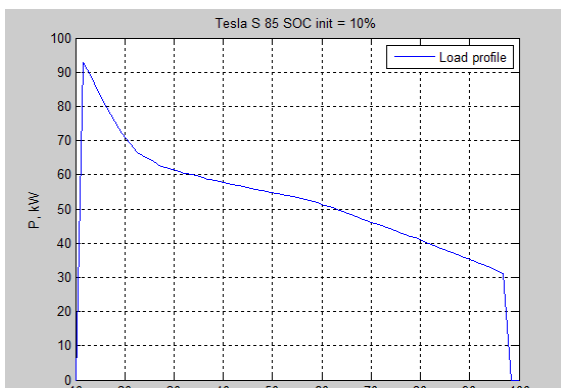

Fig. 6. State of charge of Tesla S 85 (fast charge).

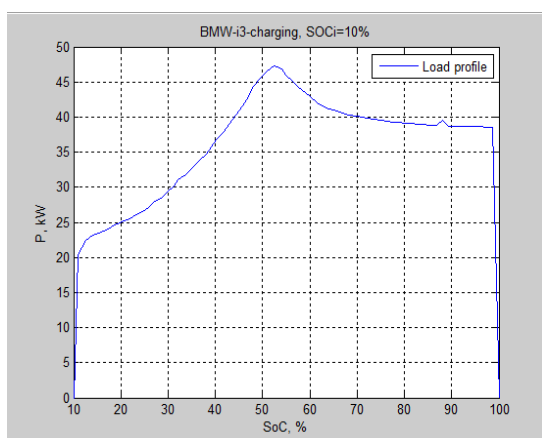

Fig. 7. State of charge of BMW i3 (fast charge)

3 Load profile and PV generation profiles

At the fig. 8 is presented the average predictive load schedule in the studied microgrid without presence of electric vehicles for a sample 24 hour period. The forecasted power generated by the PV arrays during a sample summer day is presented on fig. 9. The data from those figures is used for assessment of the grid stability without EVs and then the impacts of EV charging in the system is assessed.

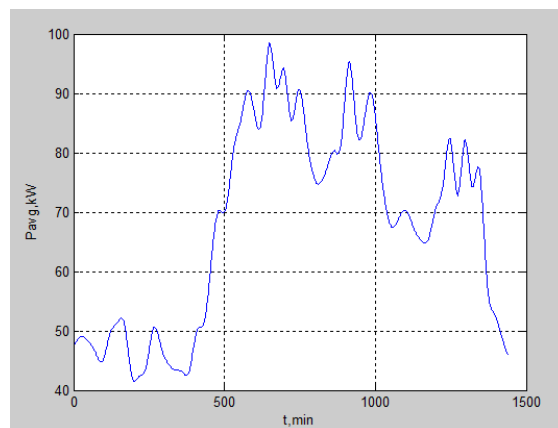

Fig. 8. Load profile forecast for a sample 24 hour period

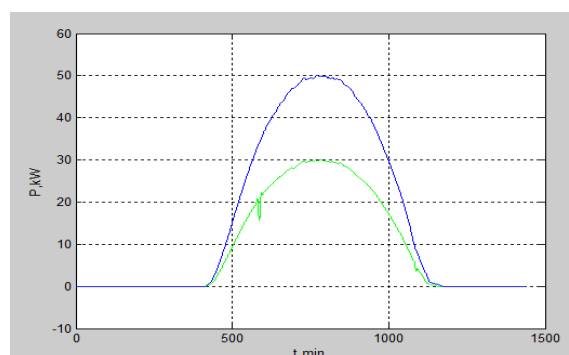

Fig. 9. PV production forecast for a sample 24 hour period

4 Resulting load profile in the microgrid

A presence of 10 electrical vehicles totaling 7% of the vehicles in the village is assumed. The average daily run per vehicle is 64 km. A distribution of the nodes of EV charger placement, starting moment of the charging and the initial SOC are presented in table 1. It is supposed that the most of the EV users will start charging their vehicles after returning home which is considered to occur most probably at 18:30h. The resulting load profile of the grid (fig. 10) contains several peaks of the load due to EV charging, although the grid parameters remain in the operational limits, imposed by the operator.

Table 1. The scenario of the operation mode

Bus №	t_i, min	Charging device load pattern
12	187	Mitsubishi i-Mi, Mode1, SOC _i =20% 3,6kW

14	557	Mitsubishi i-MiEV, Mode2, SOCi=20% 6,6kW
13	370	State of charge of Nissan leaf - 24 kW (fast charge)
17	1145	BMW i3, SOCi=10%, Mode fast charge
4	600	State of charge of Nissan leaf - 6,6 kW (fast charge)
20	850	Mitsubishi i-MiEV, Mode2, SOCi=20% 6,6kW
18	1220	Tesla S 85, SOCi=10%, Mode fast charge
10	575	BMW i3, SOCi=10%, Mode fast charge
16	1115	Tesla S 85, SOCi=10%, Mode fast charge
8	980	State of charge of Nissan leaf - 6,6 kW (fast charge)

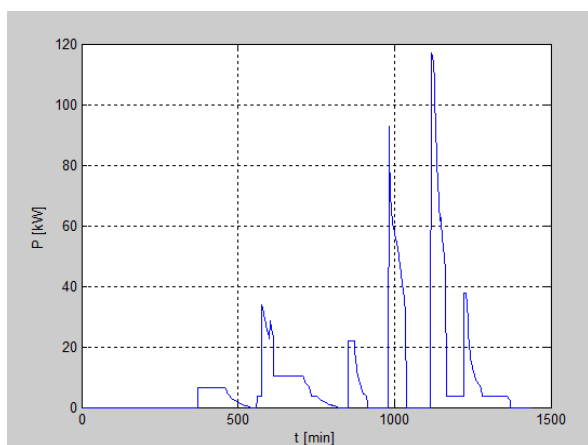

Fig. 10. Resulting load profile for the sample 24 hour period, including EV charging

4 Conclusion

A comparative analysis for assessment of the impact of electrical vehicle battery charging on the distribution grid is presented. Based on various EV charge profiles, a sample load curve and PV generators in various nodes of the grid, the time variation of grid parameters is obtained. A set of

typical load profiles of EV charging modes is studied and presented. A software implementation and a 24h case study of low voltage distribution network with EV charging devices demonstrate the impacts of EV charging on the low-voltage grid. Based on these results, the interest for future researches on bidirectional EV charging stations providing grid support in the daily periods of peak consumption is proven.

Acknowledgments:

This research is funded in the framework of project BG05M2OP001-2.009-0033 of the EU Structural Funds and „Gestion intelligente des flux énergétiques dans des micro- et nano-réseaux” funded by Agence Universitaire de la Francophonie and the Bulgarian National Fund for Scientific Research.

References:

- [1] P. Papadopoulos, “*Integration of electric vehicles into distribution Networks*,” Ph.D. thesis, Cardiff University, 2012.
- [2] Yijia Cao, Shengwei Tang, Canbing Li, Peng Zhang, et al., “*An optimized EV charging model considering TOU price and SOC curve*”, IEEE Transactions on smart grid, Vol. 3, NO. 1, p. 388- 393, March 2012
- [3] R. Stanev, M. Georgiev, A. Krusteva, “*An approach for estimation of the impact of electric vehicle charging devices on distribution networks*”, VI-th Scientific Conference „EF 2014“, Sozopol, Bulgaria, pp. 251-260, 22 – 25 Sept., 2014
- [4] R. Stanev, “*Voltage control strategies for distribution networks with distributed energy resources*”, Proceedings of the Technical University of Sofia, Vol. 63, Issue 6, pp. 263-271, 2013
- [5] A. G. Neagoe-Stefana, A. C. Neagoe, and Al. C. Mandis, “*Impact of Charging Electric Vehicles in Residential Grid on the Power Losses and Voltage Plan*”, International Symposium on Fundamentals of Electrical Engineering, Polytechnical University of Bucharest, Romania, Nov. 28, 2014
- [6] S. Schey, D. Scofield, J. Smart, “*A First Look at the Impact of Electric Vehicle Charging on the Electric Grid in The EV Project*”, International Battery, Hybrid and Fuel Cell Electric Vehicle Symposium, Los Angeles, California, May 6–9, 2012