

Dynamics of the Designed Robotic Manipulator in the CAD Program

Lucjan Setlak and Rafał Kowalik

Aviation Division, Department of Avionics and Control Systems

Polish Air Force University

Deblin 08-521, ul. Dywizjonu 303 No. 35

Poland

l.setlak@law.mil.pl, r.kowalik@law.mil.pl

Abstract: - The subject of this paper is the development of a remote control system for the arm of the robot with three degrees of freedom. The robot's control system uses an interface developed in the Matlab/Simulink programming environment based on a model designed in the CAD program, based on the process of registering natural movements of the human hand by properly defining the input quantities. The designed system, characterized in the above manner, enables control of a robotic manipulator with three degrees of freedom. The main goal of the work is to emphasize the dynamics of the manipulator on the basis of the created mathematical model defining the movement of the arm of the robot with three degrees of freedom and presenting the results of simulation tests. In view of the above, the article presents the design of a dynamic manipulator model and a model was built in the CAD program in the SolidWorks environment for the arm of the robot. The kinematic model of the manipulator was discussed with the use of joints and connectors, which in the set provide the movement of its arm with three degrees of freedom. In the final part of the work, based on a critical analysis of the research subject literature, created mathematical model of a robot manipulator and performed simulations in the Matlab/Simulink environment, and using Simulink/SimMechanics and Simulink 3D Animation in developing a simulation virtual robot model, final conclusions were made practical and outlined future orientations in the field of programming movements of manipulators and mobile robots.

Key-Words: - Dynamics of the robotic manipulator, the arm of the robot, programming environment, control object, degrees of freedom, proportional-integral-derivative (PID), mathematical model, virtual environment

1 Introduction

The division of robotic manipulators takes place depending on the criterion adopted, hence it is divided into many categories.

The basic division criterion is the division of robotic manipulators due to the number of connections, axis of rotation or axis of displacement.

At the beginning of the analyzed project, it was assumed that the created control algorithm will be described by a three-axis manipulator [1], [2], [3], [4].

Before starting the design process, possible configurations of keypads have been presented [5], [6]:

- *Cartesian (PPP)*: in this configuration, all three first connections were made of prismatic joints, which have the ability to perform the translational movement of connected elements, with such manipulators being easy to control due to fixed angles between the axes;

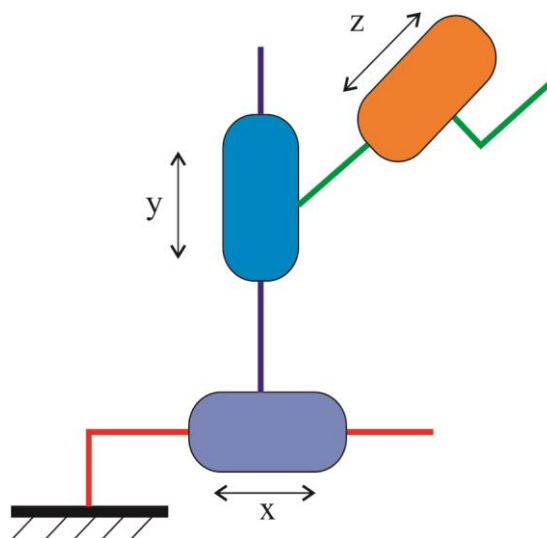

Fig. 1 Scheme of the manipulator in a PPP system made in the Paint program

- *cylindrical (OPP)*: the configuration includes one rotary joint and two prismatic joints, where the working area of the manipulator reflects the cylindrical figure;

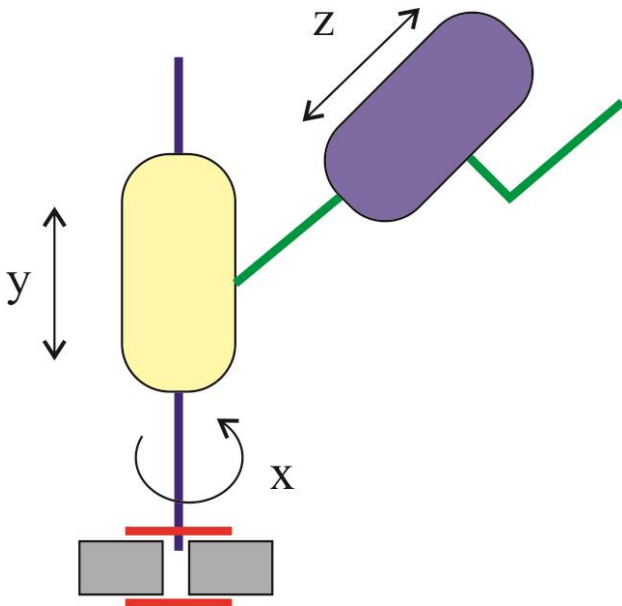

Fig. 2 Scheme of the manipulator in the OPP system made in the Paint program

- *spherical (OOP)*: a configuration containing two rotary joints, of which the axis of rotation of the second joint is set perpendicular to the axis of rotation of the first joint, where the third connection is a prismatic connection and the working range of the manipulator resembles a sphere;

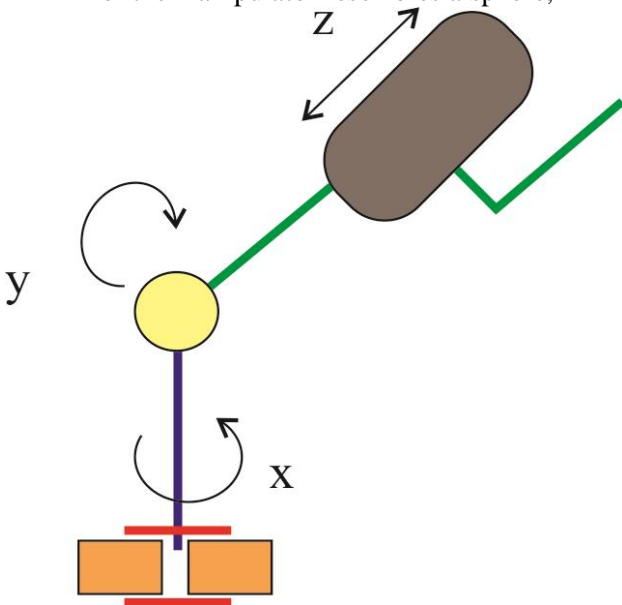

Fig. 3 Scheme of the manipulator in the OOP system made in the Paint program

- *polar (OOO)*: the configuration is also called anthropomorphic because the arm kinematics is similar to the simplified model of human hand kinematics. In this configuration, the manipulator has three rotary joints, in which the last two have a rotation axis set parallel to each other and

perpendicular to the first axis of rotation associated with the base. The operating range of the manipulator is comparable with the manipulator in configuration (OOP);

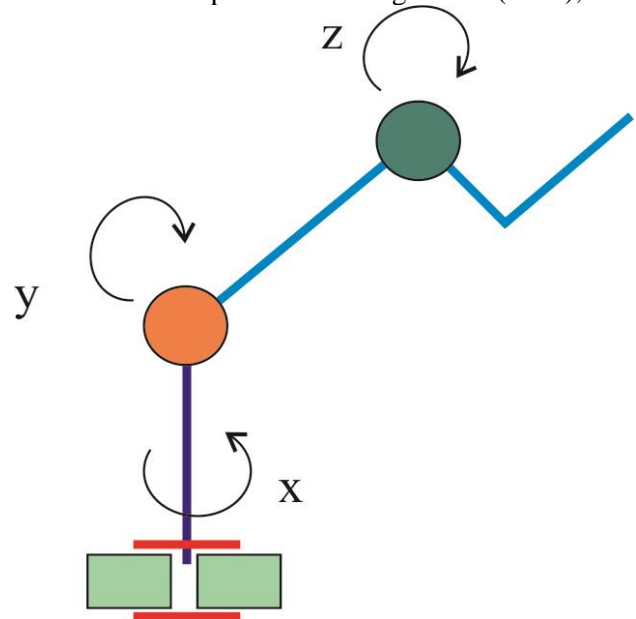

Fig. 4 Scheme of the manipulator in the OOO system made in the Paint program

- *SCARA (OOP)*: configuration is one of the most popular configurations used in industry. The structure of this manipulator is based on the spherical configuration, nevertheless the manipulator area is close to the cylindrical configuration. The SCARA (*Selective Compliant Articulated Robot for Assembly*) configuration includes two rotary joints whose axis of rotation has a mutually parallel position, and the plane of rotation is parallel to the engagement surface. The third joint is a prismatic joint that performs movements in the vertical plane, and it is also possible to mount a prismatic joint connected to the base.

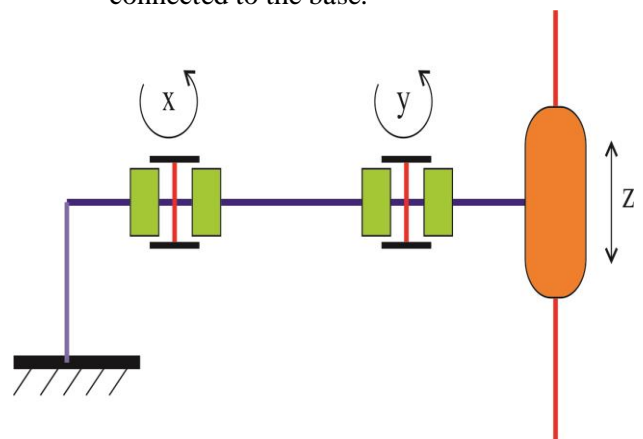

Fig. 5 Scheme of the manipulator in the SCARA (OOP) system made in the Paint program

2 Concept of the Arm Model in the CAD Program

From the above configuration types of manipulators with three joints (Figures 1-5), an anthropomorphic manipulator was chosen because it has been widely used in industry, and its construction allows for a large working space. The advantages of the manipulator OOO called 3R also include the ability to bypass obstacles. This manipulator is difficult to program due to the lack of linear drive, and according to the literature of the subject of research is referred to as the most complex structure [7], [8], [9].

The robotic arm model was made with the help of the SolidWorks 2017 program, and its construction has been simplified in order to make it more effective [10], [11]. The arm consists of four elements: a fixed base (gray) named "Part1" and three moving parts named: "Part2" (green), "Part3" (red) and "Part4" (blue).

Each of the individual parts has been marked with a different colour, allowing better visibility of individual elements and their movement relative to each other. The following figure (Fig. 6) illustrates the arm model after the assembly of four components.

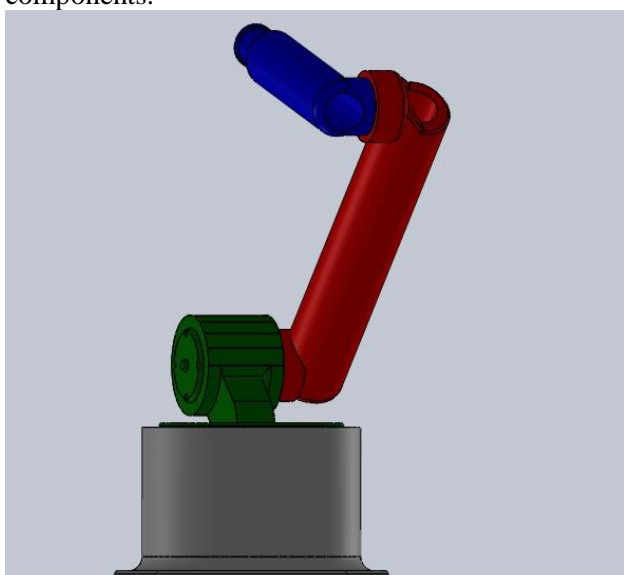

Fig. 6 Model of the anthropomorphic manipulator made in the SolidWorks 2017 program

The connection of the base to the first part, marked in green, forms the first axis of rotation, perpendicular to the plane of the base. The second and third connections form a pivot axis parallel to the base plane. This system enables rotary motion in the range from 0 to 360 degrees, taking into account the collision and penetration of individual elements. The model of this type has been deprived of its fill so its mass equals zero, which allows to omit the

force of gravity on the movement of the arm of the robot.

3 Conversion of the CAD Model to the Matlab/Simulink Environment

To import a CAD project created in the SolidWorks program to Matlab, you need the Simscape Multibody tool. If the tool is available, using the "smlink_linksw" function inside the Matlab command window, you can link the Simscape library to SolidWorks. Carrying out the above process will allow you to export the project to .XML extension, containing the files necessary to create the model. The export process has been moved to the next figure (Fig. 7).

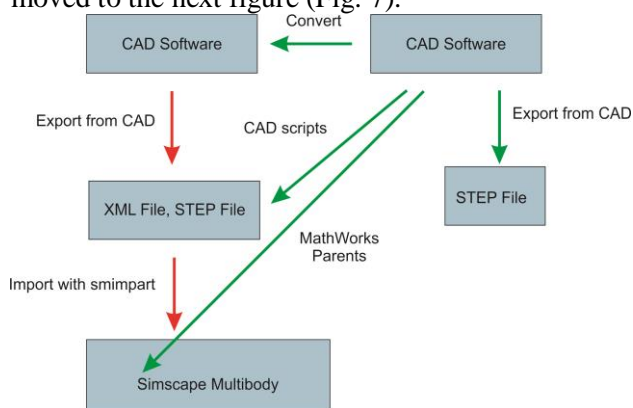

Fig. 7 Export of a CAD file to the .XML extension

The entire operation process is used to automatically generate a model, which in the further part of the work was used to obtain the robot motion animation.

4 The Kinematic Chain

The manipulator arm from the point of view of kinematics can be defined by a kinematic chain, it is more than one of the elements mutually connected with each other by means of a movable connection, e.g. a joint [12]. The following types of kinematic chains are distinguished [13], [14]:

- *flat*- if each connection has only parallel movement with respect to the others;
- *spatial*- if the connections have the possibility of movement other than parallel to each other;
- *closed*- if the kinematic scheme of the kinematic chain is closed;
- *open*- if the kinematic scheme of the kinematic chain has an open form.

It should be noted that if the kinematic chain was built in such a way that the movement of one

member determines the movement of the member with which it was connected, then in such a case the kinematic chain is determined as single-acting [15].

However, if the motion of a member does not condition the movement of another of the members, such a kinematic chain is called a non-uniform one.

The mobility of a kinematic chain is a feature of an object that defines how many degrees of freedom it possesses the entire system, which consists of each of the degrees of freedom that all the members have [16].

5 Arm Movement Model

Assuming that the number of members in the considered model is N_i , where: i - means the next number of the member. Thus, the total number of members in the system can be determined from the following formula [17], [18]:

$$n = n_1 + n_2 + \dots + n_i \tag{1}$$

Each pair consisting of "m" elements forms two "p" half-pairs, while considering the kinematics of the system, the degrees of freedom for the entire kinematic chain should be determined. For a three-axis manipulator project, where the base member is stationary, the total number of movable members is equal to $n-1$.

Each of the members before the connection had degrees of freedom equal to $x=6(n-1)$. After the connection has been made, the degrees of freedom are reduced because each of the pair receives the degree of freedom of the previous pair. In view of the above, the number of lost degrees of freedom is defined by the following formula [19]:

$$y = \sum_1^5 (6 - i) * p_i \tag{2}$$

where:

p_i - means the number of pairs of the i -th class.

The number of remaining degrees of freedom "W" is the difference of degrees of freedom before joining the degrees of freedom after the connection:

$$W = x - y \tag{3}$$

$$W = 6(n - 1) - \sum_1^5 (6 - i) * p_i \tag{4}$$

Using the formula for the designed model, the number of degrees of freedom is as follows [20]:

$$\begin{aligned} W &= 6(n - 1) - \sum_1^5 (6 - i) * p_i \\ &= 6 * (4 - 1) - 5 * 3 \\ &= 18 - 15 = 3 \end{aligned} \tag{5}$$

This means that the 3-axis manipulator has three degrees of freedom [21]. It should be noted that in order to control the robotic manipulator in such a way that it is possible to carry objects with a gripper, six degrees of freedom are needed, i.e. three degrees of freedom to move the manipulator and three to orientate the manipulator in space [22], [23].

The axis shift of the coordinate systems

An important element describing the manipulator kinematics is the value of the shift of the axis of rotation of individual elements. The shift between the member 0 and the member 1 is equal to the length l_1^0 , which is a measure of the length between the center of the coordinate system O_0 and the center of the coordinate system O_1 . The dependence of the systems shift is presented in the figure below (Fig. 8).

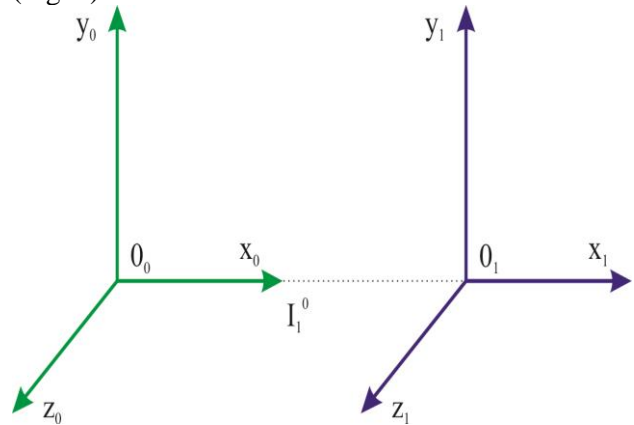

Fig. 8 Axis shift l_1^0

Determining the length of l_1^0 can be compared to the vector with the beginning at point O_0 and the end of O_1 . In this configuration the vector takes the form:

$$l_1^0 = \begin{pmatrix} l_x \\ l_y \\ l_z \end{pmatrix} \tag{6}$$

6 Vector Method of the Motion Study

To describe the trajectory of movement of the kinematic model, algebraic and matrix motion records are intended. These are the determined speed and acceleration parameters relative to the connection points of the members. The process of differentiating the position function of points in time serves to determine these quantities. The kinematic form of the scheme can be presented in the form of interconnected vectors corresponding to the movement of members or symbols of members and their connections in the classical form.

The kinematic diagram of the manipulator in the classic form is shown in the figure below (Fig. 9).

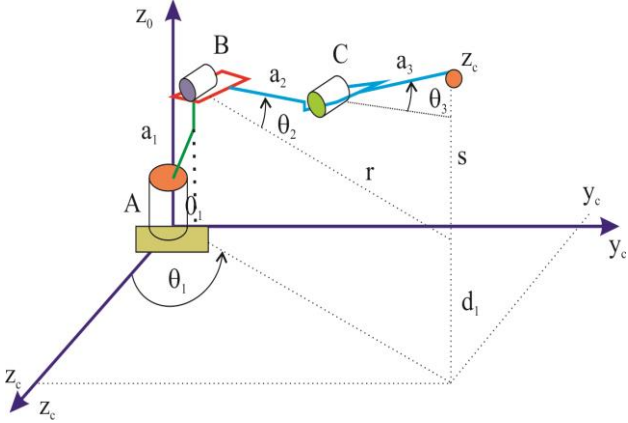

Fig. 9 Kinematic scheme of a 3-axis manipulator made in the Paint program

The above diagram shows the created manipulator arm, the scheme being oriented to the center of the manipulator base [24], [25], [26]. The base forms the rotation axis A with the first member, then the connection of the second member forms the rotation axis B, the third member forms the rotation axis C, and the point D defines the end of the manipulator and determines the possible position, e.g. the gripper. The position of point D is given by the following formula [27]:

$$\overline{p}_D(t) = \begin{bmatrix} x_D(t) \\ y_D(t) \\ z_D(t) \end{bmatrix} \quad (7)$$

The above equation (7) defines the orientation of point D in space as the projection of a point on each axis. This allows you to orient the D point with respect to the 3-axis coordinate system at time t. Based on the above formula, you can determine the position of the D point as [28]:

$$x_D(t) = [e_0 + a_2 * \cos(\theta_2(t)) + a_3 * \cos(\theta_3(t))] * \cos(\theta_1(t)) \quad (8a)$$

$$y_D(t) = [e_0 + a_2 * \cos(\theta_2(t)) + a_3 * \cos(\theta_3(t))] * \sin(\theta_1(t)) \quad (8b)$$

$$z_D(t) = a_1 + a_2 * \sin(\theta_2(t)) + a_3 * \sin(\theta_3(t)) \quad (8c)$$

To describe the motion velocity vector for point D, use the derivative of the obtained formula.

$$\overline{p}_D(t) = \begin{bmatrix} \dot{x}_D(t) \\ \dot{y}_D(t) \\ \dot{z}_D(t) \end{bmatrix} \quad (9)$$

$$\begin{aligned} &= -\sin(\theta_1(t)) \dot{x}_D(t) \\ &* \theta_1(t) * [e_0 + a_2 * \cos(\theta_2(t)) + a_3 * \cos(\theta_3(t))] + \cos(\theta_1(t)) \\ &* [-a_2 * \sin(\theta_2(t)) * \dot{\theta}_2(t) - a_3 * \sin(\theta_3(t)) * \dot{\theta}_3(t)] \end{aligned} \quad (10a)$$

$$\begin{aligned} &\dot{y}_D(t) \\ &= -\cos(\theta_1(t)) \dot{\theta}_1(t) * [e_0 + a_2 * \cos(\theta_2(t)) + a_3 * \cos(\theta_3(t))] \\ &+ \sin(\theta_1(t)) * [-a_2 * \sin(\theta_2(t)) * \dot{\theta}_2(t) - a_3 * \sin(\theta_3(t)) * \dot{\theta}_3(t)] \\ &\sin(\theta_1(t)) * [-a_2 * \sin(\theta_2(t)) * \dot{\theta}_2(t) - a_3 * \sin(\theta_3(t)) * \dot{\theta}_3(t)] \end{aligned} \quad (10b)$$

$$\begin{aligned} \dot{z}_D(t) &= a_2 * \cos(\theta_2(t)) * \dot{\theta}_2(t) + a_3 \\ &* \cos(\theta_3(t)) * \dot{\theta}_3(t) \end{aligned} \quad (10c)$$

From the above formulas (10a-10c), you can calculate the velocity of point D in relation to each axis to calculate the total speed of motion D, using the following formula of the *Pythagorean* theorem:

$$V(t) = \sqrt{\dot{x}_D(t)^2 + \dot{y}_D(t)^2 + \dot{z}_D(t)^2} \quad (11)$$

By repeating the operation and from the calculated data by calculating the derivative, you can obtain an acceleration for point D in the following form [29], [30], [31]:

$$\overline{p}_D(t) = \begin{bmatrix} \ddot{x}_D(t) \\ \ddot{y}_D(t) \\ \ddot{z}_D(t) \end{bmatrix} \quad (12)$$

$$\dot{V}(t) = a(t) = \sqrt{\ddot{x}_D(t)^2 + \ddot{y}_D(t)^2 + \ddot{z}_D(t)^2} \quad (13)$$

The presented equation easily defines the basic control parameters. In addition, by determining the derivative of the position of point D, you can calculate its speed and acceleration [32].

7 The Three Axis Response to the Control Signal

The use of the one axis control algorithm for the other two enabled control of each axis separately. The signal is entered by means of sliders in the *Slider Gain* block [33], [34], [35], [36].

Limit values for each axis have been defined: min. -10, max 10. In the simulation, the control signal was changed with the integer value every one second.

The object response was observed on the oscillator, which determined the graph shown in the next figure (Fig. 10).

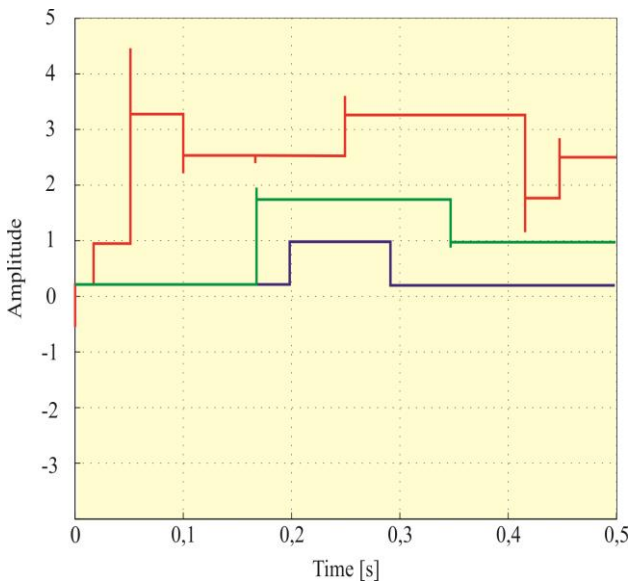

Fig. 10 Time diagram for controlling three axes

The above graph shows that the change of control values for one arm element causes an influence on the remaining axes of rotation. As a result, short-term jumps were observed that changed the position of the elements of the non-controlled system. The dislocations (precipitations) from the position were the higher the greater the change in signal at the input. Each axis returned to its previous state while remaining stable.

8 Results of Simulation Research

The results of simulation tests defining the dynamics of the arm of the robot were carried out in the Matlab/Simulink environment [37], [38], [39]. The main goal of the research was to determine the trajectory of the robot manipulator, i.e. the data characterizing the position, velocity and acceleration determined in the points on the robot's movement paths in the coordinate system in relation to time.

The individual quantities are generated for points that enable the object to move in a multidimensional Cartesian system [40], [41].

Simulation analysis was performed for three different paths defining the robot motion, with the paths considered being taken in relation to the linear motion [42], [43], [44], [45].

In turn, the trajectory of the connection (angle, velocity and acceleration) is determined in the common space by using the reverse robot kinematics phenomenon [46], [47].

The results obtained from the performed simulations are shown below (Figures 11-14).

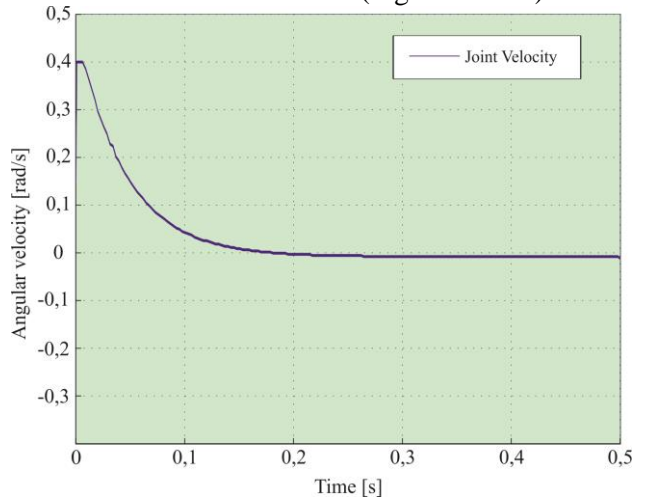

Fig. 11 Diagram of angular velocity control of the PID controller responsible for controlling of the arm of the robot

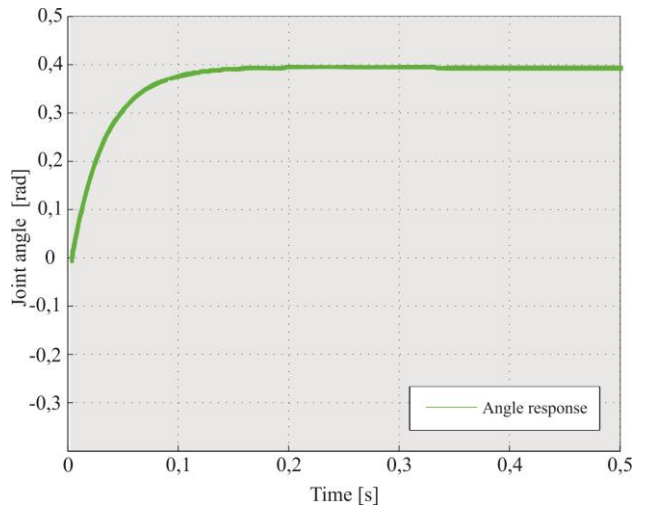

Fig. 12 Diagram of angular response of the PID controller responsible for controlling of the arm of the robot

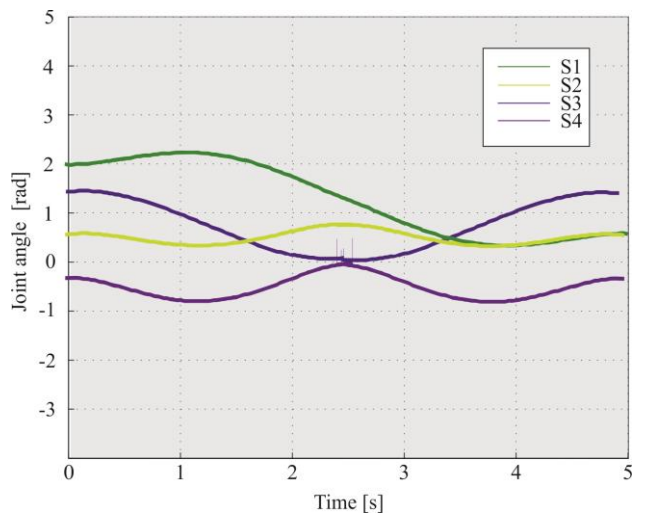

Fig. 13 Diagram of connection angles for the arm trajectory in the initial start state

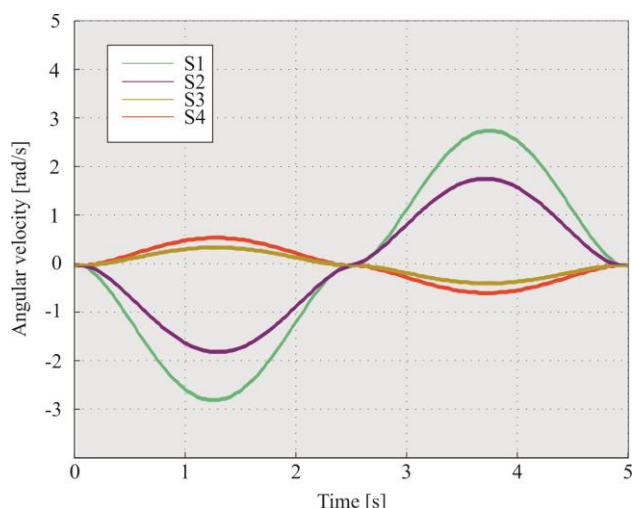

Fig. 14 Diagram of connection angles for the trajectory of the arm in the initial state of continuous operation

9 Conclusions

Computerized programs were used in the study, namely for the purposes of designing a dynamic arm model of the robot manipulator. The CAD and SolidWorks software environment was used, the simulation module was developed using the SIMULINK/SimMechanics program, using PID controllers to develop a robot control system, and the Simulink 3D Animation module was necessary for the development of a virtual robot manipulator model. It should be noted that by using computer programs for this type of research, there is never any certainty regarding their functionality outside the program, which is only a tool supporting the research process.

Before the beginning of the design part, based on the critical analysis of the literature on the subject of the research, an analysis of possible arrangements of robotic manipulators with three degrees of freedom was carried out. For the needs of the work, a 3-axis manipulator was chosen in the anthropomorphic configuration, mainly due to its good motion parameters and the difficulty in planning the control. It has been shown that a system without any control, in a short time, tends to lose its stability under the influence of small interfering signals.

Based on the conducted simulation tests, it can be concluded that the diagrams obtained from the oscillators in the case of the unstable model coincide with the chart models for this type of systems. It can be assumed that the computer program bases its operating principle on the theoretical problems in the field of control so far studied. Using the feedback system, which is one of the basic stabilization systems in automation, an improvement in the stability of the model in the simulation was

achieved. On the oscillator, the characteristics were still unstable, while the values of deflection of the robot manipulator elements reached lower values.

The work presents the characteristics of regulators used in automation, with the PID controller being used by deduction due to its versatility. After applying simple control parameters determined by trial and error, the PID controller stabilized the system. During simulation tests, the robot manipulator kept its fixed position in space when no control signal was active on the system.

This proves the correctness and efficiency of PID proportional-integral-derivative controller. In turn, to correct the error of the error, the time characteristic of the over-regulated system has been used, which is widely used in automatics, with the over-regulation value being in the range of 15-30%.

Based on the diagrams obtained from the oscillators, it can be observed that the mutual movements of the manipulators' members interact unintentionally with each other, mainly due to the moment of inertia. This may be the basis for the statement that, despite the lack of a mass input, such mass was added automatically by the Matlab program or the program downloaded the mass calculated by the SolidWorks program.

References:

- [1] Norman S. Nise, *Control system engineering*, sixth edition, John Wiley & Sons, Inc. 2011.
- [2] E.S. Grajo, A. Gunal, D. SathyaDev, O.M. Ulgen, *A Uniform Methodology for Discrete-event and Robotic Simulation*, Proceeding of the Deneb Users Group Meeting, Deneb Robotic, Inc., pp. 17-24, 1994.
- [3] S. Klug, B. Möhl, V. S. Oskar, B. Oliver, AMAM, Illmenau, Germany, September pp. 25-30, 2005.
- [4] R. L. Lieber, *Skeletal Muscle is a Biological Example of a Linear Electro-Active Actuator*", in Proceedings of SPIE's 6th Annual internationally symposium PAPER No. 3669-03, 1999.
- [5] M.P. Kazmierkowski, H. Tunia, *Automatic Control of Converter-Fed Drives*, Warszawa 1994.
- [6] R.D. Doncker, D.W.J. Pulle, and A. Veltman, *Advanced Electrical Drives: Analysis, Modeling, Control*, Springer, 2011.
- [7] K. Ogata, *Modern Control Engineering*, Third ed., Prentice Hall, 1997.
- [8] L. Setlak and R. Kowalik, *Studies of 4-rotor unmanned aerial vehicle UAV in the field of control system*, 22nd International Conference

- on Circuits, Systems, Communications and Computers (CSCC 2018), MATEC Web of Conferences, Vol. 210, pp. 1-9, 2018.
- [9] Fl. Ionescu, D. Stefanoiu, C.I. Vlad, *HYPAS - A Modular Structured Model Design, Simulation and Control of Hydraulic and Pneumatic Drive Systems by Using HYPAS*, ARA-Journal, Volume 2000-2002, No. 25-26, ISBN 3-00-011583-8, pp. 168-177, 2002.
- [10] J. Domanski, SolidWorks 2014, Projektowanie maszyn i konstrukcji, Wyd. Helion, 2014.
- [11] S. Miller, *Teoria maszyn i mechanizmów, Analiza układów kinematycznych*, Oficyna wydawnicza Politechniki Wrocławskiej, 1996.
- [12] K. Rumatowski, *Podstawy automatyki cz. 1, Układy liniowe o działaniu ciągłym*, Wyd. Politechniki Poznańskiej, 2004.
- [13] L. Zlajpah, *Simulation in robotics*, Science Direct, Mathematics and Computers in Simulation 79, pp. 879-897, 2008.
- [14] K.J. Astrom, *Feedback systems - An introduction for Scientists and Engineers*, 2007.
- [15] Z. Skup, *Podstawy automatyki i sterowania SiMR* PW, Politechnika Wrocławska, Warszawa 2012.
- [16] A. Morecki, J. Knapczyk, *Podstawy robotyki. Robotyka 2*, Wyd. Naukowo-Techniczne, Podstawy robotyki, 1994.
- [17] B. Móhl, *A Composite Drive with Separate Control of Force* in Proc. of the 11th International Conference on Advanced Robotics in Coimbra (ICAR 2003, pp. 1606-1610, 2003.
- [18] P. Robinson, *Robotics Education and Training: A Strategy for Development*, Industrial Robot. 23(2): 4-6, 1996.
- [19] N. Roth, *The International Journal of Robotics Research*, On the Kinematic Analysis of Robotic Mechanisms. 18(12): pp. 1147-1160, 1999.
- [20] R. Ranjan, A. D. Udai, A. N. Sinha, *Kinematics and Control of Biped Robot*, in Proceedings of All India seminar on Advances in product Development, Allahabad, 2006.
- [21] A. Bencsik, *Appropriate Mathematical Model of DC Servo Motors Applied in SCARA Robots*, Acta Polytechnica Hungarica Vol. 1, No. 2, pp. 99-111, 2004.
- [22] K. Tchon, A. Mazur, R. Hossa, I. Duleba, R. Muszynski, *Manipulatory i roboty mobilne, planowania ruchu, sterowanie*, Akademicka Oficyna Wydawnicza PL.J., Warszawa 2000.
- [23] Lucjan Setlak, Rafał Kowalik, Wojciech Redo, *Technological Solutions of Selected Components of Energo-electronic Power Supply System PES in the Field of AC/DC/DC, Processing in Accordance with a Trend of More Electric Aircraft*, International Journal of Circuits, Systems and Signal Processing, ISSN: 1998-4464, Volume 11, 2017.
- [24] Kazi, G. Merk, M. Otter and H. Fan, *Design optimization of industrial robots using the Modélica multi-physics modeling language*, Proceedings of the 33rd ISR (International Symposium on Robotics) October 7-11, 2002.
- [25] F. Ionescu, F. Chojnowski and G. Constantin, *Virtual Reality in Mechanical Engineering, Modelling and Simulation with Solid Dynamics*, ARA-Journal, Vol. 2002, No. 27, 2002.
- [26] F. Ionescu and D. Stefanoiu, *HYPAS-A Modular Structured Model Design, Simulation and Control Programming Environment*, Proceeding of the IASTED Intern. Confer. On Artificial and Computational Intelligence, Sept. 25-27, Tokyo, Japan, Acta Press, ISBN: 0-88986-358-X, ISSN: 1482-7913, pp. 324-329, 2002.
- [27] K. Tahboub, *Modeling and Control of Constrained Robots*, Dissertation for Ph.D. in University of Wuppertal-Germany, 1993.
- [28] Mark W. Spong, Seth Hutchinson, and M. Vidyasagar, *Robot Modeling and Control*, 1st Edition, John Wiley & Sons, 2005.
- [29] Johan J. Craig, *Introduction to Robotics Mechanics and Control*, 3rd Edition, pp. 109-114, Prentice Hall, 2005.
- [30] Chun Htoo Aung, Khin Thandar Lwin, and Yin Mon Myint, *Modeling Motion Control System for Motorized Robot Arm using Matlab*, Proceedings of World Academy of Science, Engineering and Technology Vol. 32, August 2008.
- [31] R. Mansour, *A Software Package For Computer-Aided Robotics Education*, pp. 1409-1412, 26th Annual Frontiers in Education - Vol 3, 1996.
- [32] Brandi House, Jonathan Malkin and Jeff Bilmes, *The VoiceBot: A Voice Controlled Robot Arm*, University of Washington, 2009.
- [33] P. Sorenti, *Efficient Robotic Welding in Shipyards - Virtual Reality Simulation Holds the Key*, Industrial Robot, 24(4), pp. 278-281, 1997.
- [34] M.T. Das and L.C. Dulger, *Mathematical modelling, simulation and experimental verification of a scara robot*, Simulation Modelling Practice and Theory 13, pp. 257-271, 2005.

- [35] Michel O., *Professional Mobile Robot Simulation*, International Journal of Advanced Robotic Systems", Vol. 1, No. 1, pp.39-42 ISSN 1729-8800. 2004.
- [36] Lucjan Setlak, Rafał Kowalik, Wojciech Redo, *Study of Multi-Pulse Rectifiers of the PES System in Accordance with the Concept of a More Electric Aircraft*, WSEAS Transactions on Systems and Control, ISSN/E-ISSN: 1991-8763/2224-2856, Volume 13, Art. #20, pp. 161-170, 2018.
- [37] Chun Htoo Aung, Khin Thandar Lwin, and Yin Mon Myint, *Modeling Motion Control System for Motorized Robot arm using MATLAB*, World Academy of Science, Engineering and Technology, 42, 2008.
- [38] Ahmad A. Mahfouz, Mohammed M.K., Farhan A. Salem, *Modeling, Simulation and Dynamics Analysis Issues of Electric Motor, for Mechatronics Applications, Using Different Approaches and Verification by MATLAB-Simulink (I)*, IJISA Vol. 5, No. 5, pp. 39-57 April 2013.
- [39] Farhan A. Salem, *Modeling controller selection and design of electric DC motor for Mechatronics applications, using different control strategies and verification using MATLAB/Simulink*, Submitted to European Scientific Journal, 2013.
- [40] Muhammad Ikhwan Jambak, Habibollah Harón, Dewi Nasien, *Development of Robot Simulation Software for Five Joints Mitsubishi RV-2AJ Robot using MATLAB, Simulink and V-Realm Builder*, Fifth International Conference on Computer Graphics, Imaging and Visualization, 2008.
- [41] Leniel Braz de Oliveira Macaferi, *Construction and Simulation of a Robot Arm with Opengl*, May 16, 2007.
- [42] Arya Wirabhuanal, Habibollah bin Harón, *Industrial Robot Simulation Software Development Using Virtual Reality Modeling Approach (VRML) and Matlab-Simulink Toolbox*, University Teknologi Malaysia, 2004.
- [43] A. Gronowicz, *Podstawy analizy układów kinematycznych*, Oficyna Wydawnicza Politechniki Wrocławskiej, Wrocław 2003.
- [44] Lucjan Setlak, Rafał Kowalik, *Stability Evaluation of the Flight Trajectory of Unmanned Aerial Vehicle in the Presence of Strong Wind*, WSEAS Transactions on Systems and Control, ISSN/E-ISSN: 1991-8763/2224-2856, Volume 14, , Art. #6, pp. 43-50, 2019.
- [45] K. Fayeq, B. Keith, and T. Nick, *International Conference on Control, Robotics and Cybernetics (ICCRC 2011)*, 978-1-4244-9709-6/11, 2011.
- [46] D. Horla, *Podstawy automatyki*, Poznan, 3, Wydawnictwo Politechniki Poznańskiej, 2011.
- [47] J. Kowal, *Podstawy automatyki*, T. 1, Wydawnictwo AGH, 2006.