

# Using the Transformation Matrices Not Only to Derive the Motion Equations

JIRI ZATOPEK

Tomas Bata University in Zlin  
Department of Automatic and Control Engineering  
Nad Stranemi 4511, 760 05 Zlin  
CZECH REPUBLIC  
zatopek@fai.utb.cz

*Abstract:* This article introduces different ways of transformation matrices use. The first utilization is to determine the motion equations of the complex mechanical structure. Analysed model is designed in 3D CAD system SolidWorks. It consists of seven main physical objects. The corresponding inertia/pseudo-inertia matrix is derived for each of them with the aid of transformation matrices. These matrices are further used to derive the motion equations. The ball position scanning by camera system provides another possibility of the transformation matrix use; the camera local coordinate system is different against the plate local coordinate system and it is necessary to recalculate the real ball position. The final mentioned use of transformation matrices is in the determination of ball falling direction - it is valid only in case of its zero initial velocity.

*Key-Words:* Motion Control, Transformation Matrix, Motion Equations, Gradient, Simulation, Matlab/Simulink

## 1 Introduction

Derivation of systems motion equations (deductive identification) is a crucial part of designing the motion control law of any mechanical structure. These structures are composed of mass objects and acts by not inconsiderable effect on other components of the system.

Each mass object has inertia in the motion. These inertias are reflected in the form of centrifugal/centripetal and Coriolis generalized forces with the combination of rotational movements - non-linearity into the system is introduced. The whole system has, therefore, highly non-linear behaviour during fast movements - non-linearities are bounded to the rate of change of state variables largely.

The system which is the object of our interest is called "Ball and plate", shown in Fig. 1. To derive the equations of motion of the system the transformation matrices individual parts are advantageous to know. These transformation matrices can be further used for derivation of the inertia matrix, the position determining of the individual parts of the assembly in a 3D space, and non-measurable state variables obtaining - during the whole process procedure. The matrix form of Lagrange equations of the second type there will be used, which involves the use of the transformation matrices directly.

The Denavit-Hartenberg (DH) notation/method of placement for coordinate systems is used to deter-

mine the transformation matrices. The position measurement of the ball on the plate is realized using the camera system. As shown in Fig. 10, with respect to the fixed location of the camera is necessary to transform the camera measured position of the ball to the actual position of the ball on the plate. Even in this case, the transformation matrix method is advantageously uses.

## 2 Ball and plate

### 2.1 3D model

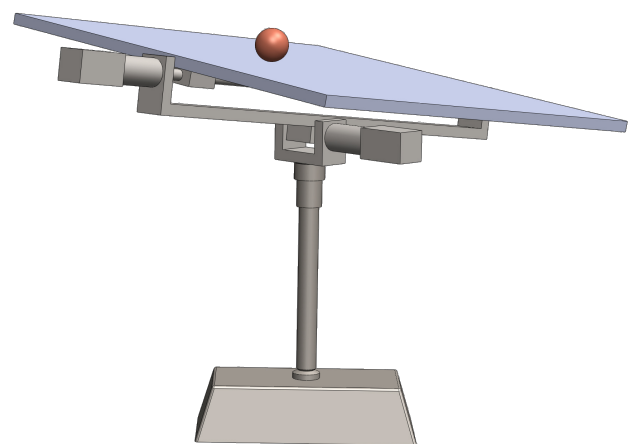

Figure 1: Total 3D model

Fig. 1 shows a complete 3D assembly model. This model is created in SolidWorks and has 4 generalized degrees of freedom. Tilts of the plate are two of them. They are realized by two rotary kinematic pairs in perpendicular relation to their common normal. The ball position on the plate are other two generalized degree of freedom.

For purposes of determining the system dynamic characteristics is preferably to simplify the system to the extent not too complicated equations of motion and at the same time the dynamic characteristics of the simplified model not be much different from the behaviour of the original system.

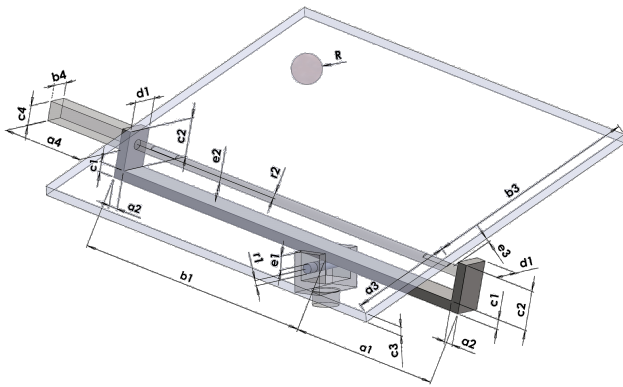

Figure 2: Simplified 3D model

The simplified model shown in Fig. 2 contains only parts that have a major influence on its dynamics or serves as a global coordinate system base.

There are generally shown the basic dimensions that will be used in the coordinate system transformation - will be possible to change them in the resulting equation.

The stand as a base and the first motor need not be taken into account because they do not perform any movement (they are fixed) - as well as the connecting parts with negligible mass. The motor that moves the plate is replaced by cuboid.

## 2.2 Transformation of coordinate systems

Table 1: DH parameters general table

Link	$a_i$	$\alpha_i$	$\theta_i$	$d_i$
1	$a_1$	$\alpha_1$	$\theta_1$	$d_1$
2	$a_2$	$\alpha_2$	$\theta_2$	$d_2$
...	...	...	...	...
n	$a_n$	$\alpha_n$	$\theta_n$	$d_n$

The model is divided into seven parts for determining the homogeneous coordinates of the system.

The part which is the transformation relates is always shown in the accompanying figures.

Used Denavit-Hartenberg (DH) notation/method of placement for coordinate systems is probably the most popular method used in robotics kinematics.

The calculation of the required transformations from the Table 1 is performed using the following relationships:

$${}^{i-1}T_i = \begin{bmatrix} \cos \theta_i & -\cos \alpha_i \sin \theta_i & \sin \alpha_i \sin \theta_i & a_i \cos \theta_i \\ \sin \theta_i & \cos \alpha_i \cos \theta_i & -\sin \alpha_i \cos \theta_i & a_i \sin \theta_i \\ 0 & \sin \alpha_i & \cos \alpha_i & d_i \\ 0 & 0 & 0 & 1 \end{bmatrix} \quad (1)$$

$${}^0T_n = {}^0T_1 \dots {}^{n-2}T_{n-1} {}^{n-1}T_n \quad (2)$$

$$G_R = {}^G T_B \cdot B_r \quad (3)$$

The ball transformation in a global coordinate system is listed here as a pattern, other transformations have similar characteristics. The global coordinate system ( $X_0, Y_0, Z_0$ ) is positioned at the rotation center axis of the first motor, as shown in Fig. 3.

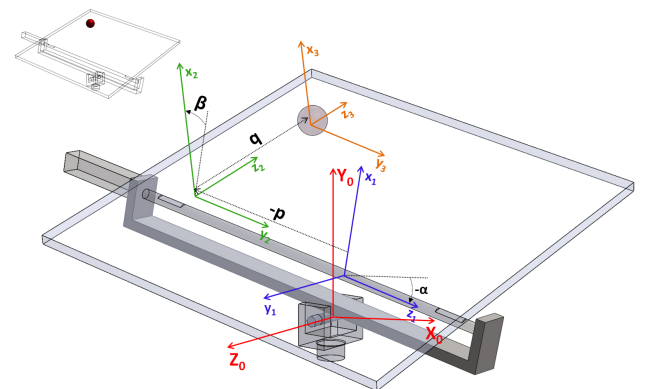

Figure 3: Coordinate system placement - part 7

Table 2: DH parameters - part 7

Link	$a_i$	$\alpha_i$	$\theta_i$	$d_i$
1	$e_1 + r_1 + c_1 + e_2 + r_2$	$\frac{\pi}{2}$	$\frac{\pi}{2}$	$\frac{\pi}{2} + \alpha$
2	$r_2 + e_3 + c_3 + R$	$\frac{\pi}{2}$	$p$	$\beta$
3	0	0	$q$	0

The gradual transformations from the Fig. 3 can be written in Table 2. Utilising the relationship in the Equation 1 is found the transformation matrix between systems.

Equation 2 is used for finding the final transformation matrix from the local body coordinate system - chosen at the center of gravity, into the global coordinate system.

It is possible to determine the position vector ball in the global coordinate system (ball position in 3D space) by using the Equation 3.

The matrix  ${}^0T_3$  is listed in Equation 4. It is labelled as  $T_7$  according to the selected assembly parts numbering.

$$T_7 = \begin{bmatrix} -\cos \beta \sin \alpha & \cos \alpha & -\sin \alpha \sin \beta & T_7^1 \\ \cos \alpha \cos \beta & \sin \alpha & \cos \alpha \sin \beta & T_7^2 \\ \sin \beta & 0 & -\cos \beta & T_7^3 \\ 0 & 0 & 0 & 1 \end{bmatrix} \quad (4)$$

in which:

$$T_7^1 = p \cos \alpha - \sin \alpha (c_1 + e_1 + e_2 + r_1 + r_2) - q \sin \alpha \sin \beta - \cos \beta \sin \alpha (R + c_3 + e_3 + r_2)$$

$$T_7^2 = \cos \alpha (c_1 + e_1 + e_2 + r_1 + r_2) + p \sin \alpha + q \cos \alpha \sin \beta + \cos \alpha \cos \beta (R + c_3 + e_3 + r_2)$$

$$T_7^3 = \sin \beta (R + c_3 + e_3 + r_2) - q \cos \beta$$

Transformation of the remaining parts of the assembly are given in Equations 5 - 10, Tables 3 - 8 and comes from Fig. 4 - 9.

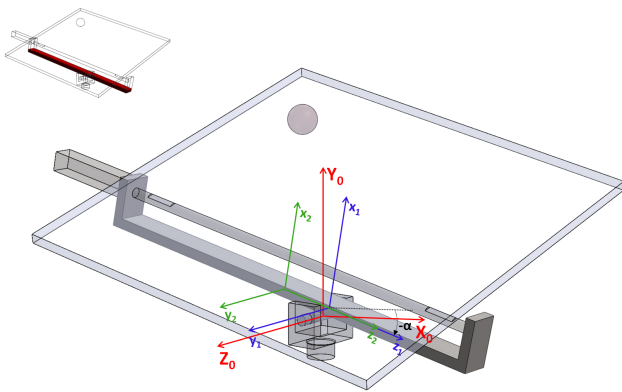

Figure 4: Coordinate system placement - part 1

Table 3: DH parameters - part 1

Link	$a_i$	$\alpha_i$	$\theta_i$	$d_i$
1	$e_1 + r_1 + \frac{c_1}{2}$	$\frac{\pi}{2}$	0	$\frac{\pi}{2} + \alpha$
2	0	0	$\frac{a_1 - b_1}{2}$	0

$$T_1 = \begin{bmatrix} -\sin \alpha & 0 & \cos \alpha & T_1^1 \\ \cos \alpha & 0 & \sin \alpha & T_1^2 \\ 0 & 1 & 0 & 0 \\ 0 & 0 & 0 & 1 \end{bmatrix} \quad (5)$$

in which:

$$T_1^1 = \cos \alpha \frac{a_1 - b_1}{2} - \sin \alpha \left( \frac{c_1}{2} + e_1 + r_1 \right)$$

$$T_1^2 = \sin \alpha \frac{a_1 - b_1}{2} + \cos \alpha \left( \frac{c_1}{2} + e_1 + r_1 \right)$$

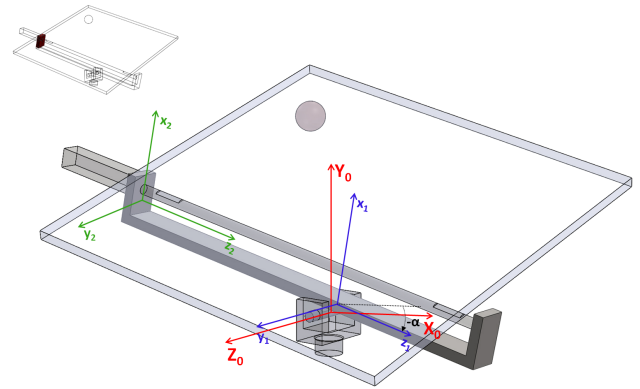

Figure 5: Coordinate system placement - part 2

Table 4: DH parameters - part 2

Link	$a_i$	$\alpha_i$	$\theta_i$	$d_i$
1	$e_1 + r_1 + \frac{c_1}{2}$	$\frac{\pi}{2}$	0	$\frac{\pi}{2} + \alpha$
2	$\frac{c_1 + c_2}{2}$	0	$\frac{a_2}{2} - b_1$	0

$$T_2 = \begin{bmatrix} -\sin \alpha & 0 & \cos \alpha & T_2^1 \\ \cos \alpha & 0 & \sin \alpha & T_2^2 \\ 0 & 1 & 0 & 0 \\ 0 & 0 & 0 & 1 \end{bmatrix} \quad (6)$$

in which:

$$T_2^1 = \cos \alpha \left( \frac{a_1}{2} - b_1 \right) - \sin \alpha \left( c_1 + \frac{c_2}{2} + e_1 + r_1 \right)$$

$$T_2^2 = \sin \alpha \left( \frac{a_1}{2} - b_1 \right) + \cos \alpha \left( c_1 + \frac{c_2}{2} + e_1 + r_1 \right)$$

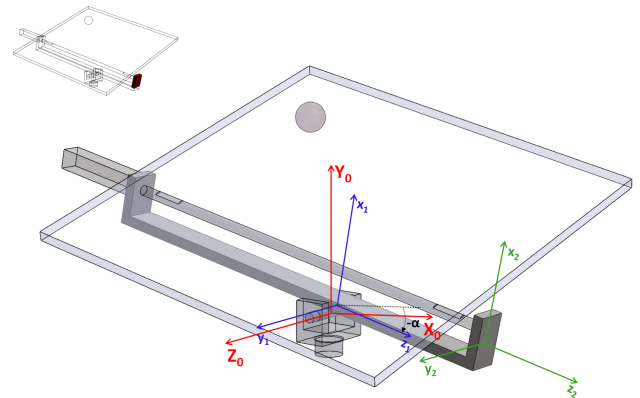

Figure 6: Coordinate system placement - part 3

Table 5: DH parameters - part 3

Link	$a_i$	$\alpha_i$	$\theta_i$	$d_i$
1	$e_1 + r_1 + \frac{c_1}{2}$	$\frac{\pi}{2}$	0	$\frac{\pi}{2} + \alpha$
2	$\frac{c_1 + c_2}{2}$	0	$a_1 - \frac{a_2}{2}$	0

$$T_3 = \begin{bmatrix} -\sin \alpha & 0 & \cos \alpha & T_3^1 \\ \cos \alpha & 0 & \sin \alpha & T_3^2 \\ 0 & 1 & 0 & 0 \\ 0 & 0 & 0 & 1 \end{bmatrix} \quad (7)$$

in which:

$$T_3^1 = \cos \alpha \left( a_1 - \frac{a_2}{2} \right) - \sin \alpha \left( c_1 + \frac{c_2}{2} + e_1 + r_1 \right)$$

$$T_3^2 = \sin \alpha \left( a_1 - \frac{a_2}{2} \right) + \cos \alpha \left( c_1 + \frac{c_2}{2} + e_1 + r_1 \right)$$

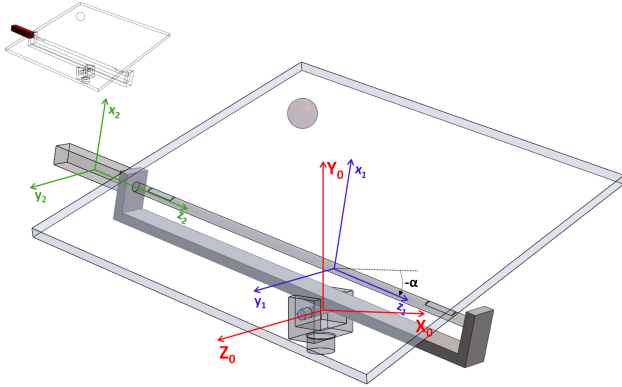

Figure 7: Coordinate system placement - part 4

Table 6: DH parameters - part 4

Link	$a_i$	$\alpha_i$	$\theta_i$	$d_i$
1	$e_1 + r_1 + c_1 + e_2 + r_2$	$\frac{\pi}{2}$	0	$\frac{\pi}{2} + \alpha$
2	0	0	$-\frac{2b_1+a_4}{2}$	0

$$T_4 = \begin{bmatrix} -\sin \alpha & 0 & \cos \alpha & T_4^1 \\ \cos \alpha & 0 & \sin \alpha & T_4^2 \\ 0 & 1 & 0 & 0 \\ 0 & 0 & 0 & 1 \end{bmatrix} \quad (8)$$

in which:

$$T_4^1 = -\sin \alpha (c_1 + e_1 + r_1 + e_2 + r_2) - \cos \alpha \left( b_1 + \frac{a_4}{2} \right)$$

$$T_4^2 = \cos \alpha (c_1 + e_1 + r_1 + e_2 + r_2) - \sin \alpha \left( b_1 + \frac{a_4}{2} \right)$$

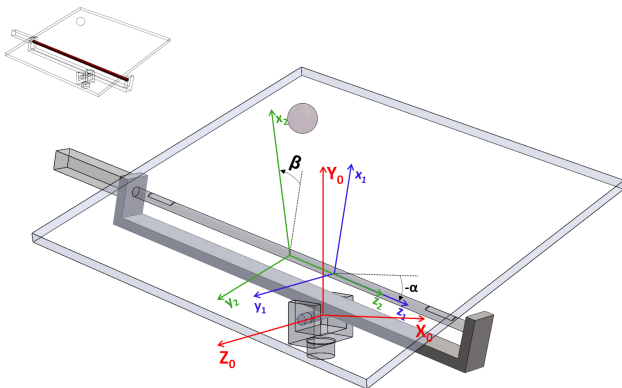

Figure 8: Coordinate system placement - part 5

Table 7: DH parameters - part 5

Link	$a_i$	$\alpha_i$	$\theta_i$	$d_i$
1	$e_1 + r_1 + c_1 + e_2 + r_2$	$\frac{\pi}{2}$	0	$\frac{\pi}{2} + \alpha$
2	0	0	$\frac{a_1-b_1}{2}$	$\beta$

$$T_5 = \begin{bmatrix} -\cos \beta \sin \alpha & \sin \alpha \sin \beta & \cos \alpha & T_5^1 \\ \cos \alpha \cos \beta & -\cos \alpha \sin \beta & \sin \alpha & T_5^2 \\ \sin \beta & \cos \beta & 0 & 0 \\ 0 & 0 & 0 & 1 \end{bmatrix} \quad (9)$$

in which:

$$T_5^1 = \cos \alpha \frac{a_1 - b_1}{2} - \sin \alpha (c_1 + e_1 + r_1 + e_2 + r_2)$$

$$T_5^2 = \sin \alpha \frac{a_1 - b_1}{2} + \cos \alpha (c_1 + e_1 + r_1 + e_2 + r_2)$$

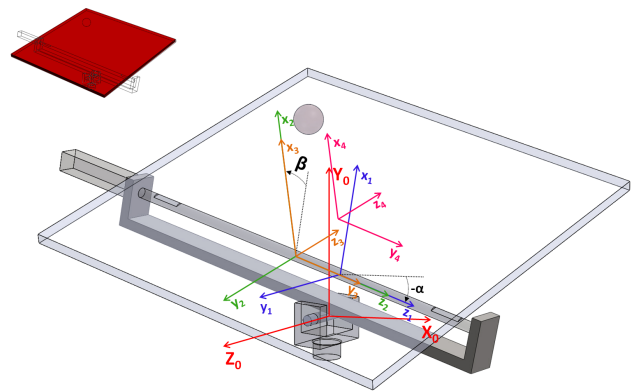

Figure 9: Coordinate system placement - part 6

Table 8: DH parameters - part 6

Link	$a_i$	$\alpha_i$	$\theta_i$	$d_i$
1	$e_1 + r_1 + \frac{c_1}{2}$	$\frac{\pi}{2}$	0	$\frac{\pi}{2} + \alpha$
2	0	0	$\frac{a_1-b_1}{2}$	$\beta$
3	0	$\frac{\pi}{2}$	0	0
4	$r_2 + e_3 + \frac{c_3}{2}$	0	$\frac{b_3-a_3}{2}$	0

$$T_6 = \begin{bmatrix} -\cos \beta \sin \alpha & \cos \alpha & -\sin \alpha \sin \beta & T_6^1 \\ \cos \alpha \cos \beta & \sin \alpha & \cos \alpha \sin \beta & T_6^2 \\ \sin \beta & 0 & -\cos \beta & T_6^3 \\ 0 & 0 & 0 & 1 \end{bmatrix} \quad (10)$$

in which:

$$T_6^1 = \cos \alpha \frac{a_1 - b_1}{2} - \sin \alpha (c_1 + e_1 + r_1 + e_2 + r_2) + \sin \alpha \sin \beta \frac{a_3 - b_3}{2} - \cos \beta \sin \alpha \left( r_2 + e_3 + \frac{c_3}{2} \right)$$

$$T_6^2 = \sin \alpha \frac{a_1 - b_1}{2} + \cos \alpha (c_1 + e_1 + r_1 + e_2 + r_2) - \cos \alpha \sin \beta \frac{a_3 - b_3}{2} + \cos \alpha \cos \beta \left( r_2 + e_3 + \frac{c_3}{2} \right)$$

$$T_6^3 = \cos \beta \frac{a_3 - b_3}{2} + \sin \beta \left( r_2 + e_3 + \frac{c_3}{2} \right)$$

### 2.3 Motion Equations

Motion equations matrix form of serial manipulator has the general form:

$$D(\bar{q}) \cdot \ddot{\bar{q}} + \bar{H}(\bar{q}, \dot{\bar{q}}) + \bar{G}(\bar{q}) = \bar{Q} \quad (11)$$

in which:

$D(\bar{q})$  ... symmetric inertia matrix

$\bar{H}(\bar{q}, \dot{\bar{q}})$  ... bounded velocity vector

$\bar{G}(\bar{q})$  ... gravitational force vector

$\bar{Q}$  ... non-potential (non-conservative) generalized forces causing change of  $\bar{q}$

Individual parts of the Equation 11 can be decomposed to the form:

$$D_{i,j} = \sum_{r=\max\{i,j\}}^n tr \left[ \frac{\partial^0 T_r}{\partial q_j} \cdot {}^r \bar{I}_r \left( \frac{\partial^0 T_r}{\partial q_i} \right)^T \right] \quad (12)$$

$$H_i = \sum_{k=1}^n \sum_{m=1}^n H_{ikm} \dot{q}_k \dot{q}_m \quad (13)$$

$$H_{ikm} = \sum_{r=\max\{i,k,m\}}^n tr \left[ \frac{\partial^2 {}^0 T_r}{\partial q_k \partial q_m} \cdot {}^r \bar{I}_r \left( \frac{\partial^0 T_r}{\partial q_i} \right)^T \right] \quad (14)$$

$$G_i = - \sum_{r=i}^n m_r ({}^0 \bar{g})^T \cdot \frac{\partial^0 T_r}{\partial q_i} \cdot {}^r \bar{r}_r \quad (15)$$

in which:

$n$  ... number of links

$i, j$  ... state variables

$\bar{I}$  ... pseudo-inertia matrix

${}^0 \bar{g}$  ... gravitational vector in global coordinate system

${}^r \bar{r}_r$  ... the center of mass position vector of link in the local coordinate system

The gravitational vector  ${}^0 \bar{g}$  is in the direction of the global axis  $Y$ , therefore:

$${}^0 \bar{g} = \begin{bmatrix} 0 \\ -g \\ 0 \\ 1 \end{bmatrix} \quad (16)$$

The center of mass position vector of link is zero in his local coordinate system - all the local coordinate systems are placed in the body center of mass:

$${}^r \bar{r}_r = \begin{bmatrix} r_x \\ r_y \\ r_z \\ 1 \end{bmatrix} = \begin{bmatrix} 0 \\ 0 \\ 0 \\ 1 \end{bmatrix} \quad (17)$$

Only the last unknown parameter is missing in Equation 11 - the pseudo-inertia matrix  $\bar{I}$ .

#### 2.3.1 Inertia matrix

The inertia matrix of individual assembly parts is also need to know to derive the pseudo-inertia matrices in their local coordinate system. Because the local coordinate system are always placed in the object center of mass the deviance moments (i.e. off-diagonal elements) of inertia matrices will be zero.

The numbering is similar as for the transformation matrices.

$$I_1 = \frac{m_1}{12} \begin{bmatrix} (a_1+b_1)^2+d_1^2 & 0 & 0 \\ 0 & (a_1+b_1)^2+c_1^2 & 0 \\ 0 & 0 & c_1^2+d_1^2 \end{bmatrix} \quad (18)$$

$$I_2 = I_3 = \frac{m_2}{12} \begin{bmatrix} a_2^2+d_1^2 & 0 & 0 \\ 0 & a_2^2+c_2^2 & 0 \\ 0 & 0 & c_2^2+d_1^2 \end{bmatrix} \quad (19)$$

$$I_4 = \frac{m_4}{12} \begin{bmatrix} a_4^2+b_4^2 & 0 & 0 \\ 0 & a_4^2+c_4^2 & 0 \\ 0 & 0 & b_4^2+c_4^2 \end{bmatrix} \quad (20)$$

$$I_5 = \frac{m_5}{12} \begin{bmatrix} 3r_2^2+(a_1+b_1-2a_2)^2 & 0 & 0 \\ 0 & 3r_2^2+(a_1+b_1-2a_2)^2 & 0 \\ 0 & 0 & r_2^2 \end{bmatrix} \quad (21)$$

$$I_6 = \frac{m_6}{12} \begin{bmatrix} (a_3+b_3)^2+d_3^2 & 0 & 0 \\ 0 & (a_3+b_3)^2+c_3^2 & 0 \\ 0 & 0 & c_3^2+d_3^2 \end{bmatrix} \quad (22)$$

$$I_7 = \frac{2}{5} m_7 R^2 \begin{bmatrix} 1 & 0 & 0 \\ 0 & 1 & 0 \\ 0 & 0 & 1 \end{bmatrix} \quad (23)$$

#### 2.3.2 Pseudo-inertia matrix

$$\bar{I} = \begin{bmatrix} \frac{-I_{xx}+I_{yy}+I_{zz}}{2} & I_{xy} & I_{xz} & mr_x \\ I_{yx} & \frac{I_{xx}-I_{yy}+I_{zz}}{2} & I_{yz} & mr_y \\ I_{zx} & I_{zy} & \frac{I_{xx}+I_{yy}-I_{zz}}{2} & mr_z \\ mr_x & mr_y & mr_z & m \end{bmatrix} \quad (24)$$

The general definition of pseudo-inertia matrix is listed in Equation 24. Now there is all you need to derive the resulting motion equations - Equation 11.

$$I_{1P} = \begin{bmatrix} \frac{m_1 c_1^2}{12} & 0 & 0 & 0 \\ 0 & \frac{m_1 d_1^2}{12} & 0 & 0 \\ 0 & 0 & \frac{m_1 (a_1+b_1)^2}{12} & 0 \\ 0 & 0 & 0 & m_1 \end{bmatrix} \quad (25)$$

$$I_{2P} = I_{3P} = \begin{bmatrix} \frac{m_2 c_2^2}{12} & 0 & 0 & 0 \\ 0 & \frac{m_2 d_1^2}{12} & 0 & 0 \\ 0 & 0 & \frac{m_2 a_2^2}{12} & 0 \\ 0 & 0 & 0 & m_2 \end{bmatrix} \quad (26)$$

$$I_{4P} = \begin{bmatrix} \frac{m_4 c_4^2}{12} & 0 & 0 & 0 \\ 0 & \frac{m_4 b_4^2}{12} & 0 & 0 \\ 0 & 0 & \frac{m_4 a_4^2}{12} & 0 \\ 0 & 0 & 0 & m_4 \end{bmatrix} \quad (27)$$

$$I_{5P} = \begin{bmatrix} \frac{m_5 r_2^2}{4} & 0 & 0 & 0 \\ 0 & \frac{m_5 r_2^2}{4} & 0 & 0 \\ 0 & 0 & \frac{m_5 (a_1 - 2a_2 + b_1)^2}{12} & 0 \\ 0 & 0 & 0 & m_5 \end{bmatrix} \quad (28)$$

$$I_{6P} = \begin{bmatrix} \frac{m_6 c_3^2}{12} & 0 & 0 & 0 \\ 0 & \frac{m_6 d_3^2}{12} & 0 & 0 \\ 0 & 0 & \frac{m_6 (a_3 + b_3)^2}{12} & 0 \\ 0 & 0 & 0 & m_6 \end{bmatrix} \quad (29)$$

$$I_{7P} = \begin{bmatrix} \frac{m_7 R^2}{5} & 0 & 0 & 0 \\ 0 & \frac{m_7 R^2}{5} & 0 & 0 \\ 0 & 0 & \frac{m_7 R^2}{5} & 0 \\ 0 & 0 & 0 & m_7 \end{bmatrix} \quad (30)$$

### 2.4 The ball position on the plate

Obviously, the transformation matrix using is not only refer to the motion equations. The system has four generalized degree of freedom as Section 2.1 shows. This state variable is need to know during all the regulation process.

Tilts of the plate are given by encoders on the motors which controls them. However, the ball position on the plate is unknown - it rolls independently in the direction of the fastest decrease in potential energy - a negative gradient. It is given by the tilt of the plate.

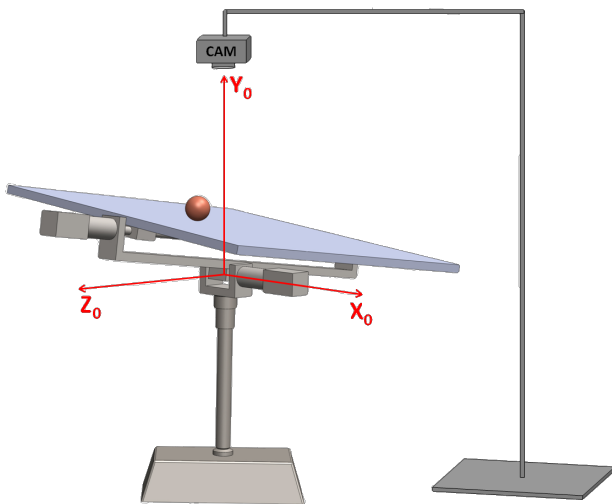

Figure 10: 3D Model with camera evaluation

The ball position on the plate is measured by using a camera, which is placed as shown in Fig. 10 - the optical axis of the camera is identical to the global axis  $Y_0$  and the plate edges are parallel to the camera pixel array edges. The ball coordinates on axes  $X_0$  and  $Z_0$  are measured by this placement, not the size of the  $p$  and  $q$  as shown in Fig. 3.

The best way would be moving the camera and the plate together, but it is ineffective from the construction and control viewpoint. However, the  $p$  and  $q$  parameters is possible to calculate with the transformation matrices help.

The ball position in the global coordinate system is expressed from Equation 3.

$$\begin{aligned} X &= p \cos \alpha - \sin \alpha (c_1 + e_1 + e_2 + r_1 + r_2) - \\ &\quad - q \sin \alpha \sin \beta - \cos \beta \sin \alpha (R + c_3 + e_3 + r_2) \\ Y &= \cos \alpha (c_1 + e_1 + e_2 + r_1 + r_2) + p \sin \alpha + \\ &\quad + q \cos \alpha \sin \beta + \cos \alpha \cos \beta (R + c_3 + e_3 + r_2) \\ Z &= \sin \beta (R + c_3 + e_3 + r_2) - q \cos \beta \end{aligned} \quad (31)$$

Parameters  $p$  and  $q$  are expressed from Equation 31,  $X$  and  $Z$  are measured by the camera system.

$$\begin{aligned} X &= \frac{\sin \alpha \sin \beta [Z - \sin \beta (R + c_3 + e_3 + r_2)] + \\ &\quad + \sin \alpha (c_1 + e_1 + e_2 + r_1 + r_2) + \\ &\quad + \cos \beta \sin \alpha (R + c_3 + e_3 + r_2)}{\cos \alpha} \\ p &= \frac{\sin \beta (R + c_3 + e_3 + r_2) - Z}{\cos \beta} \end{aligned} \quad (32)$$

All the state variables are already fully defined. If the vertical ball position is necessary to know in the global coordinate system, state variables  $p$  and  $q$  just put into  $Y$  in Equation 31.

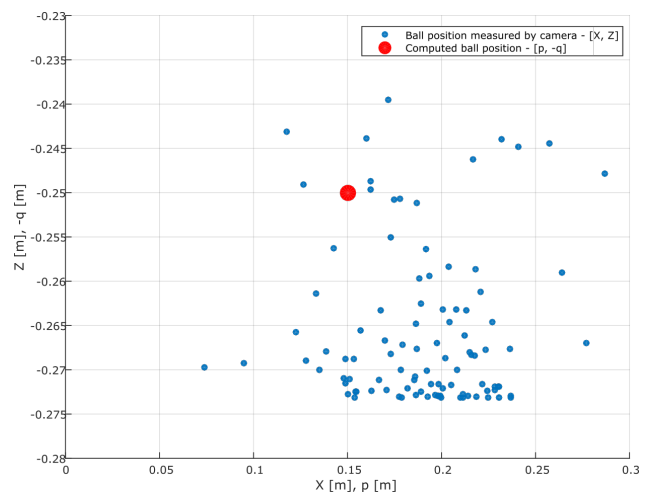

Figure 11: Difference between measured ball position by camera and real (computed) ball position



In Fig. 11 is shown correct (computed) ball position (red point) and measured ball position by camera (blue points) in dependence on the tilt of the beam ( $\alpha$  and  $\beta$ ). The tilt of the beam was chosen randomly in an interval  $(-30^\circ, 30^\circ)$ . Parameters  $p$  and  $q$  are invariable in this case (ball is firmly connected with plate). The ball position in axis  $Z$  is approximately in the range  $(-0.273\text{ m}, -0.24\text{ m})$ . The ball position in axis  $X$  is approximately in the range  $(0.075\text{ m}, 0.285\text{ m})$  - more than  $6x$  larger range than  $Z$  range. This is caused by a perpendicular placing of the first rotation axis - the rotation axis of tilt  $\alpha$ , which affects the ball position in the  $X$  axis. It is placed below the plate axis and therefore do not tilted the plate only, but it also moves with the plate in the  $X$  axis.

## 2.5 Ball falling direction

The ball falling direction determining is listed as a final example of use the transformation matrix. This needs to know the orientation of the inclined plate in 3D space, which can be determined by the transformation matrix  $T_7$  - Equation 4. All constants can be chosen zero, the tilts of the plate are known. The local coordinate system of the plate will be moved to any 3 points of this plate. General transformation matrix ( $T_G$ ), which will be further work with, is shown in Equation 33.

$$\mathbf{T} = \begin{bmatrix} -\cos\beta \sin\alpha & \cos\alpha & -\sin\alpha \sin\beta & T^1 \\ \cos\alpha \cos\beta & \sin\alpha & \cos\alpha \sin\beta & T^2 \\ \sin\beta & 0 & -\cos\beta & -q \cos\beta \\ 0 & 0 & 0 & 1 \end{bmatrix} \quad (33)$$

in which:

$$\begin{aligned} T^1 &= p \cos\alpha - q \sin\alpha \sin\beta \\ T^2 &= p \sin\alpha + q \cos\alpha \sin\beta \end{aligned}$$

Searched 3 points are determined by changing the  $p$  and  $q$  parameters (unitary length is chosen). The normal vector  $w$  is determined with their help:

$$\vec{w} = (\cos\beta \sin\alpha, -\cos\beta \cos\alpha, -\sin\beta) \quad (34)$$

This vector defines the general form of the equation of a plane. It can be written as Equation 34 after editing. Its local coordinate system is oriented the same as the global coordinate system (because of the transformation matrix definition - the transformation from the local coordinate system to the global coordinate system):

$$y = \frac{\sin\alpha}{\cos\alpha} x - \frac{\sin\beta}{\cos\beta \cos\alpha} z \quad (35)$$

The components of the gradient in coordinates are the partial derivative of the scalar field function - Equation 35:

$$\nabla y = \left( \frac{\sin\alpha}{\cos\alpha}, -\frac{\sin\beta}{\cos\beta \cos\alpha} \right) \quad (36)$$

Gradient in Equation 36 determines the greatest rate of increase of the function. The vector of gravity is situated in the negative direction of the global axis  $Y_0$ , therefore, the negative gradient direction determines the fastest decrease in potential energy, and therefore the direction where the ball will move by influence of gravity.

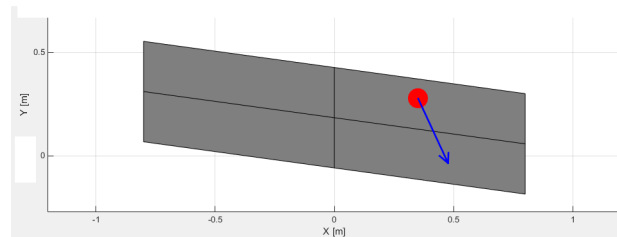

Figure 12: Ball falling direction in 2D view - MATLAB

In Fig. 12 is displayed the "Ball and plate" model with the ball falling direction vector for  $\alpha = -10^\circ$ ,  $\beta = 30^\circ$ . Set of the ball falling direction vectors is shown in Fig. 13. The tilt waveforms of the plate are shown in the upper graph. These inclines and gravity then determine the ball falling direction vectors - the bottom left graph. The vectors are normalized and stretched into a time line for better clarity, how follow in order - the bottom right graph.

## 3 Conclusion

The article contains derivations of the transformation, inertia matrices and all other required formalities necessary for the determine motion equations using the matrix form shown in Equation 11. The substitution into the Equation 11 and the resultant form is not listed here due to the high dimensionality of the resulting expression. This substitutions and mathematics adjustments are implemented in MATLAB.

The model is divided into 7 parts for ease identifying and acceptable inertia matrices form - each part is one of the basic shapes. These parts connection occurs during substituting into the Equation 11. Transformation matrices are designed to transform the local coordinate system position (connected with the object center of mass) to the global coordinate system. This connection ensures zero inertia matrix deviance moments and therefore zero pseudo-inertia matrices off-diagonal elements.

Transformation matrices are also used in the regulated value determining, which is different from the correct values, with respect to the fixed camera location to the moving plate. It is used for conversion

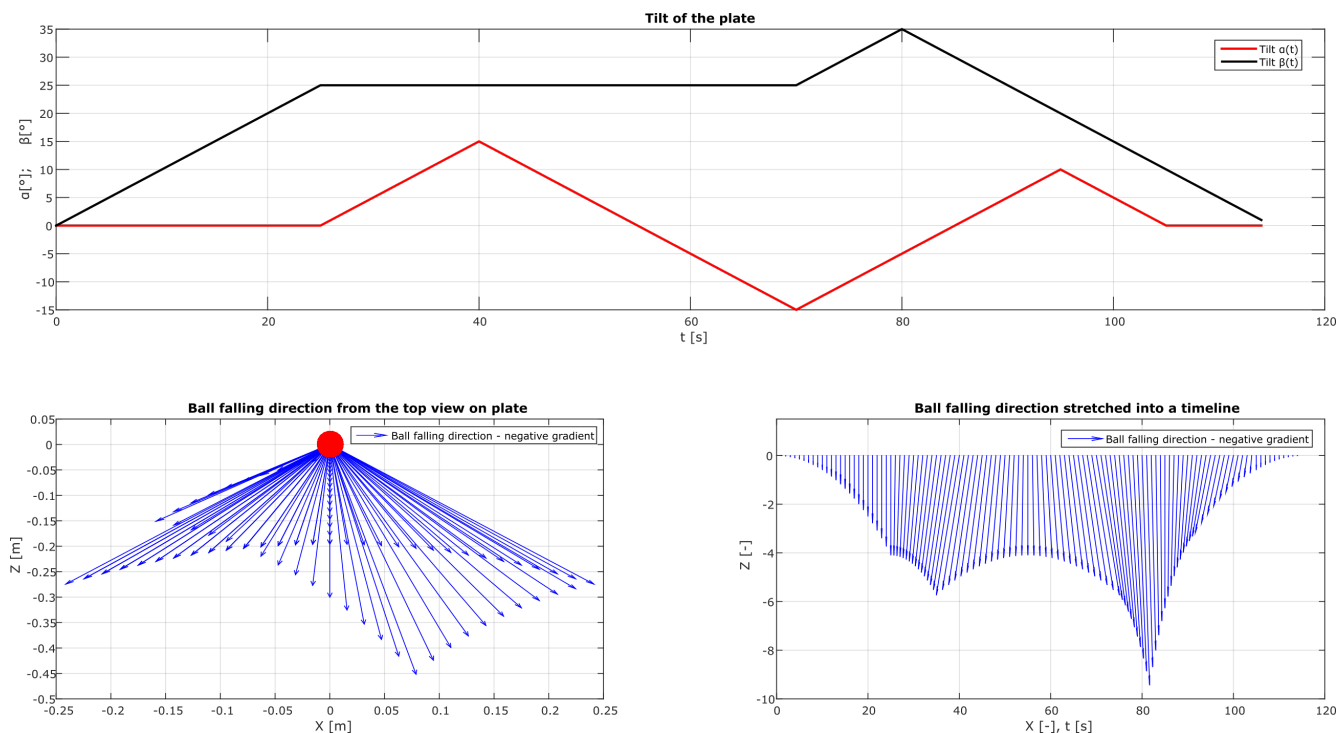

Figure 13: Set of ball falling direction vectors depending on the tilt of the plate

between the measured and the real output/regulated value.

Another usage of transformation matrices is in the determination of the ball falling direction. In that case we will be able to say what size and direction the ball will be falling in case of its zero initial velocity.

Suitable coordinate system placement and then the transformation matrix form is a key consideration as follows from the foregoing. It is important from the viewpoint of complexity of other calculations, from the perspective of finding potential errors or their further use - correctness of the transformation matrix can be easily geometrically verified, which cannot be said about the system dynamics describing structures.

#### References:

- [1] S. Crandall, D. C. Karnopp and E. F. Kurz, *Dynamics of mechanical and electromechanical systems*, McGraw-Hill, New York, 1968.
- [2] H. K. Khali, *Nonlinear Systems*, Upper Saddle River, N. J: Pearson, 2001.
- [3] J. Denavit and R. S. Hartenberg, A kinematic notation for lower-pair mechanisms based on matrices, *ASME J. Ap. Rob.* 77, 1955, pp. 215-221.
- [4] R. N. Jazar, *Theory of Applied Robotics*, Springer US, Boston, 2010.
- [5] Y. Shaoqiang, L. Zhong and L. Xingshan, Modelling and simulation of robot based on Matlab/SimMechanics, *Chin. Contr. Conf.* 27, 2008, pp. 161-165.
- [6] Z. Uredniecek, *Robotika*, Tomas Bata university in Zlin, Zlin, 2012.
- [7] Z. Uredniecek, *Elektromechanicke akcni cleny*, Tomas Bata university in Zlin, Zlin, 2009.
- [8] R. C. Rosenberg, Multiport Models in Mechanic *J. Dyn. Sys., Meas., Con.* 94, pp. 206-212, 1972
- [9] D. C. Karnopp and R. C. Rosenberg, *System dynamics*, A Unifies Approach. Wiley & Sons, New York, 1975.
- [10] M.-T. Ho, Y. Rizal and L.-M. Chu, Visual Servoing Tracking Control of a Ball and Plate System: Design, Implementation and Experimental Validation *Int. J. Adv. Robot. Syst.* 10, 2013, pp. 287-302.
- [11] X. Dong, Y. Zhao, Y. Xu, Z. Zhang and P. Shi, Design of PSO Fuzzy Neural Network Control for Ball and Plate System *Int. J. Inn. Comp. Inf. Contr.* 7, 2011, pp. 7091-7103.