

Mechanism-hydraulic Co-simulation Research on the Test Bed of Gun Recoil Mechanism

Yuliang YANG, Changchun DI, Junqi QIN, Yanfeng YANG

Department of Artillery Engineering

Ordnance Engineering College

Shijiazhuang

China (Beijing)

^ayyl_liang@sina.com

Abstract: In the test bed of recoil mechanism, recoil mechanism completed the recoil and counterrecoil process, pushed by hydraulic cylinder. The test bed consisted of the mechanical system, the hydraulic system and the electrical system. Based on ADAMS software and EASY5 software, the dynamic model and hydraulic system model of test bed were respectively built. On the basis of these models, mechanism-hydraulic co-simulation model of test bed was built, and co-simulation analysis was developed. The movement curves of piston rod and pressure curves of accumulators were obtained. The study will provide a theoretical basis for the engineering application of test bed.

Key-Words: -recoil mechanism; test bed; dynamic model; plug-in valve; hydraulic system model; co-simulation.

1 Introduction

Recoil mechanism is a core part of gun system, and gun performance depends largely on it. Gun recoil mechanism varied in types and structure sizes. After the decomposition and combination in army and factories, some simple methods were usually used to check up the performance of recoil mechanism, for example artificial boost, gas leakage detection, liquid leakage detection and so on. These methods were not universal and quantitative, which were difficult to meet the need of various guns maintenance and detection. In this paper, a new type test bed of recoil mechanism was studied on the structure and principle analysis. Based on virtual prototyping technology, co-simulation model of test bed was built and analyzed.

2 Test bed structure of recoil mechanism

The test bed of gun recoil mechanism consisted of the mechanical system, the hydraulic system and the electrical system. In the test bed of recoil

mechanism, recoil mechanism completed the recoil and counterrecoil process, pushed by hydraulic cylinder. The design index of the test bed was that the maximum recoil and counterrecoil velocity of recoil mechanism should be above 1m/s.

The mechanical system consisted of the recoil mechanism, the test bench, the connecting seat, the force sensor, the high speed hydraulic cylinder and so on, shown in Figure 1. For the different types of recoil mechanism, back support bushings, front support bushings and sleeve can be adjusted to expand the application scope.

The hydraulic system consisted of hydraulic pumps, displacement sensors, plug-in valves, high-pressure accumulators, low pressure accumulators, filters, relief valves, check valves, the data acquisition and control system and so on. High pressure accumulators and plug-in valves were used to provide large flow of fluid oil in the dynamic impact process. The data acquisition and control system was used to receive test signals of sensors and control the valve components.

The electrical system consisted of the operational console, the PLC control system, the device protection circuit and the laser printer. PLC control system was the control core of the electrical system. The operational console was used to set forces limits and positions limits. When the

resistance was above normal more than 20 percent, the device protection circuit started to run, at one time the test bed stopped and saved test data. The laser printer was used to print test data and test curves, fulfilling the data output function.

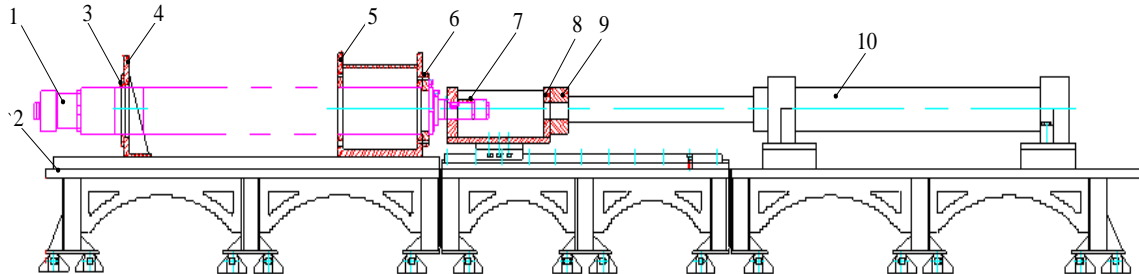

Figure 1 Test bed of recoil mechanism

1-recoil mechanism; 2-test bench; 3-back support bushings; 4-back support;
5-front support; 6-front support bushings; 7-sleeve; 8-connecting seat;
9-force sensor; 10-high speed hydraulic cylinder

3 Test bed modeling

Take a certain type of gun recuperator for example, mechanism-hydraulic co-simulation model of test bed was built based on virtual prototyping technology.

3.1 Dynamic Model

Based on dynamic simulation software ADAMS [2, 3], dynamic model of test bed was built, of which recoil mechanism was recuperator, shown in Figure 2. Dynamic model mainly consisted of three parts, hydraulic cylinder, recuperator and connecting device.

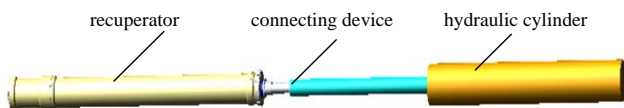

Figure 2 Dynamic model of test bed

Lagrange multiplier method was used to build dynamic equations automatically by ADAMS software, and impact hinge was introduced in the form of equivalent impact force to dynamic equations [4]. The dynamic equations of the test bed were described as follow.

$$\begin{cases} M\ddot{q} + \Phi_q = Q + F_g \\ \Phi(q, t) = 0 \end{cases} \quad (1)$$

Where, q was the generalized coordinate array; M, Φ_q, Q were respectively the generalized mass matrix, the Jacobi matrix of constraint equations $\Phi(q, t) = 0$ and the generalized force matrix. F_g was the generalized force matrix of contact force F , which can be calculated by the entity impact model based on impact function [5].

During the recoil process, recuperator provided recoil resistance [4, 5]. Recuperator was hydropneumatic, of which operational principle was shown in figure 3.

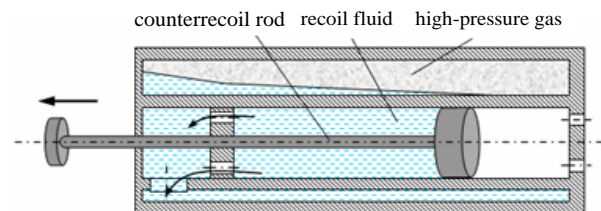

Figure 3 Operational principle of recuperator

In the recuperator, gas was the storage medium, and liquid acted to transmit force and sealing gas. During the recoil process, gas in the recuperator was compressed due to the movement of the

counterrecoil rod, which produced recoil resistance to the piston through the liquid.

Change of gas pressure was described by the polytropic process.

$$p_f \gamma^n = p_{f0} \gamma_0^n = \cos nt \quad (2)$$

Where, P_f 、 P_{f0} were respectively the instantaneous pressure and the initial pressure of gas in the recuperator; γ 、 γ_0 were respectively the instantaneous volume and the initial volume of gas in the recuperator; n was the polytropic exponent, depended on the heat transfer condition and the piston velocity.

Regardless of friction, recoil resistance can be described as follow [6, 7].

$$F_f = A_f p_f = A_f p_{f0} \left(\frac{\gamma_0}{\gamma}\right)^n \quad (3)$$

Where, A_f was the work area of recuperator piston.

Introduced the equivalent length of initial recuperator volume $l_0 = V_0 / A_f$, then the volume of any gas was $V = V_0 - A_f x = A_f (l_0 - x)$. Equation (3) can be described

$$F_f = A_f p_{f0} \left(\frac{l_0}{l_0 - x}\right)^n \quad (4)$$

3.2 Hydraulic system model

As the hydraulic cylinder has a high speed during the work process of test bed, so the high hydraulic flow was needed. Plug-in valves and accumulator were used in the hydraulic system model to achieve the goal.

3.2.1 Plug-in valve model

Four plug-in valves were used in the hydraulic system model, work principle of plug-in valve was shown in Figure4.

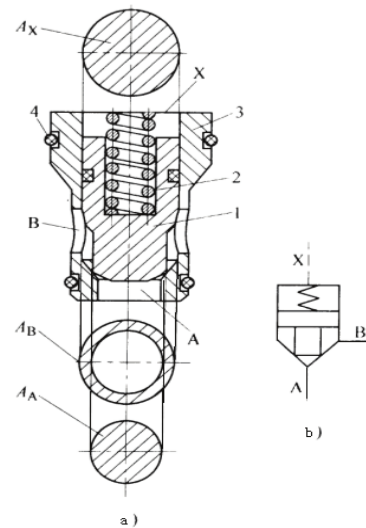

1-valve core; 2-spring; 3-valve sleeve; 4-seal

Figure 4 Structure of plug-in valve

Through the above structural analysis, the mathematical model of plug-in valve can be obtained. Regardless of valve core gravity and friction, force equation of valve core of plug-in valve was:

$$p_A A_A + p_B A_B - p_X A_X - k(x_0 + x_L) - F_2 = m_L \ddot{x}_L \quad (5)$$

Where, p_A , p_B , p_X were respectively the chambers pressure of A, B and X; A_A , A_B , A_X were respectively the effective action areas of the three chambers; k was the spring stiffness; x_0 was the initial spring compression; x_L was the valve core displacement; m_L was the valve core mass; F_2 was the steady-state flow force,

$F_2 = 2c\pi d_A x_L (p_A - p_B) \cos \alpha$, c was the valve orifice flow coefficient, α was the valve orifice taper

Flow equation of plug-in valve was:

$$Q = 2c\pi d_A x_L \sin \alpha \sqrt{\frac{2(p_A - p_B)}{\rho}} \quad (6)$$

3.2.2 Hydraulic system model

Based on hydraulic simulation software EASY5, hydraulic system model of test bed was built, shown in Figure 5.

The work process of test bed consisted of three stages, energy storage stage, stroke stage and return stage.

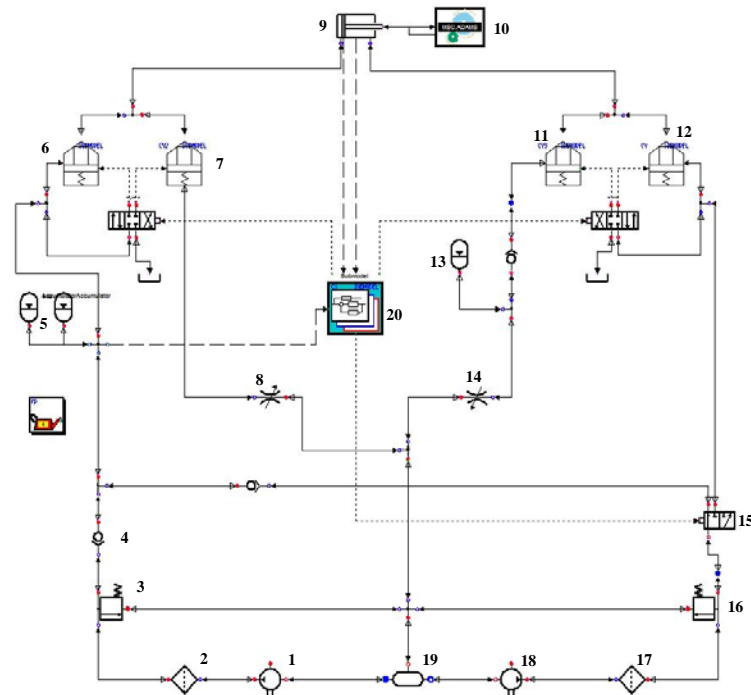

1, 18- hydraulic pump; 2, 17-filter; 3, 16- relief valve; 4-check valve; 5- high pressure accumulator; 6, 7, 11, 12- plug-in valve; 8, 14 throttle valve; 9- hydraulic cylinder; 10-ADAMS interface; 13-low pressure accumulator; 15-reversing valve; 19-tank; 20-control system

Figure 5 Hydraulic system schemes

(1) Energy storage stage: the hydraulic pumps 1 and 18 were open to provide oil to high pressure accumulator 5 at the same time.

(2) Stroke stage: when the pressure of high pressure accumulator reached a certain value, open the plug-in valves 6 and 11, two hydraulic pumps and the high pressure accumulator provided oil to the left chamber of hydraulic cylinder, pushing the piston rod move to a high speed. The hydraulic oil in the right chamber of hydraulic cylinder 9 flowed through the plug-in valve 11 into low pressure accumulator 13.

(3) Return stage: when the stroke stage finished, closed plug-in valves 6 and 11, opened plug-in valves 7 and 12, the piston rod of hydraulic cylinder returned to the initial position by the recuperator.

Hydraulic cylinder is the coupled component of dynamic model and hydraulic system model. The two models are connected by the ADAMS Mechanism module of hydraulic cylinder. Based on the hydraulic system model, when the ADAMS mechanism module was added, the connection between EASY5 software and ADAMS software was completed [8], and the co-simulation model of test bed was built.

3.3 Co-simulation model

The driving force of the piston rod was obtained based on the hydraulic system model built in EASY5 software. The displacement and velocity of the piston rod were obtained based on the dynamic model built in ADAMS software. Parameters relation of the dynamic model and hydraulic system model was shown in Figure. 6.

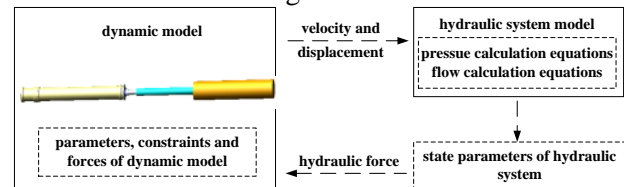

Figure 6 Parameters relation of the dynamic model and the hydraulic system model

4 Simulation analysis of test bed

Based on the mechanism-hydraulic co-simulation model, co-simulation analysis was developed. When the pressure of the high pressure accumulator was 12MPa, the plug-in valves 6 and 11 were open, and the stroke stage started. When the counterrecoil rod reached a certain position, the return stage started.

4.1 Displacement and velocity of piston rod

Based on the co-simulation model, displacement and velocity curves of piston rod in one work

process were obtained by simulation analysis, shown in Figure 7 and Figure 8.

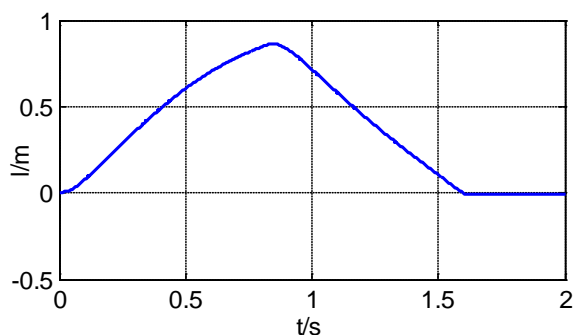

Figure 7 Displacement of piston rod

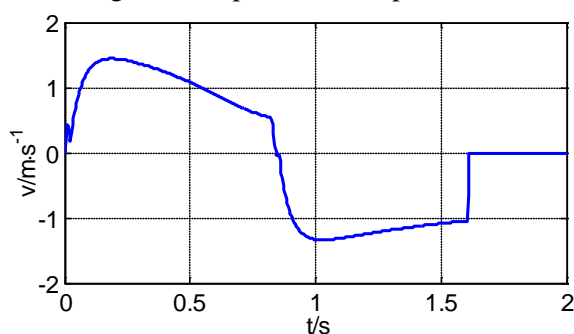

Figure 8 Velocity of piston rod

The piston rod of hydraulic cylinder and counterrecoil rod were fastened together, so the two parts had the same displacement and velocity. To save the simulation time, the initial pressure of high pressure accumulator was set to 12MPa, so the stroke stage started firstly. As can be seen from Figure 7 and Figure 8, the maximum recoil velocity of counterrecoil rod was 1.443m/s in the stroke stage(0~0.848s), and the maximum counterrecoil velocity of counterrecoil rod was 1.339m/s in the return stage(0.848~1.613s), which were greater than 1m/s. The test bed spent 1.613 second to complete one test process.

4.2 Accumulator pressure

During the simulation process, the initial pressure of high-pressure accumulator was set to 12MPa, based on the co-simulation model, the pressure curves of high-pressure accumulator and low-pressure accumulator in one work process were obtained by simulation analysis, shown in Figure 9 and Figure 10.

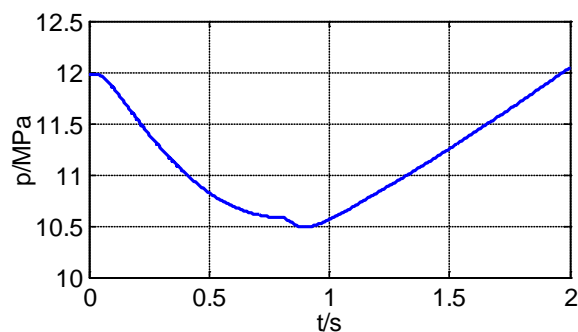

Figure 9 Pressure of high-pressure accumulator

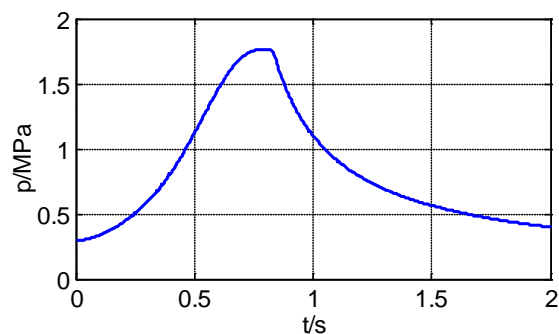

Figure 10 Pressure of low-pressure accumulator

As can be seen from Figure 9 and Figure 10, during the stroke stage, the pressure of high-pressure accumulator was reduced from 12MPa to 10.49MPa, and the pressure of low-pressure accumulator was raised from 0.3MPa to 1.76MPa. When the stroke stage finished, two hydraulic pumps simultaneously provided oil to the high-pressure accumulator, which was raised to 12MPa at 1.982s. at the same time, the pressure of low-pressure accumulator was reduced to the initial pressure. From the simulation analysis above, the test bed spent about 2s to complete the recoil and counterrecoil process.

5 Conclusion

The structure and operational principle of the test bed of recoil mechanism were discussed, which consisted of the the mechanical system, the hydraulic system and the electrical system.

Based on the ADAMS software and EASY5 software, the dynamic model and hydraulic system model of the test bed were built. Then the mechanism-hydraulic co-simulation model of test bed was built, and co-simulation analysis was developed. The maximum recoil and counterrecoil velocity of counterrecoil rod were greater than 1m/s, which indicated that the test bed design met the initial performance index. The test bed spent about 2s to complete the recoil and counterrecoil process. The test bed can be used to improve the

performance detection and maintenance support, and the study will provide a theoretical basis for the engineering application of test bed.

References:

- [1] Changzhi JIA, Renxi HU, Xiuju DU, et al. Study on Design Evaluation of Recoil System of Guns Based on Virtual Prototyping Technology[J]. Journal of System Simulation. 2007, 19(12): 2746-2749.
- [2] Ruilin WANG, Yongjian LI, Junnuo ZHANG. Modeling Technology and Application of Small Arms Based on Virtual Prototype[M]. National Defense Industry Press, 2014.
- [3] Jianrong ZHENG. Introduction and Rise of Adams Virtual Prototyping Technology [M] Beijing: Mechanical Industry Press, 2002.
- [4] Wei LI, Jisheng MA, Changchun DI, et al. Simulation Research on Dynamics of Ramming System and Action Reliability Considering the Randomness of the Parameters[J]. ACTA ARMAMENTARII, 2012, 33(6): 747-752.
- [5] Msc Company. Adams/ View user guide[DB/CD]. California: Msc Company, 2005.
- [6] Peilin ZHANG, Guozhang LI, Jianping FU. Fire System of Self-propelled Artillery [M]. Beijing: Weapon Industry Press, 2002.
- [7] Shuzi GAO, Yunsheng CHEN, Yuelin ZHANG, et al. Gun Recoil System Design [M]. Beijing: Weapon Industry Press, 1995.
- [8] Lin LIU. Conceptual Design and Simulation of Power System of Recoil Test Machine with Muzzle Impact [D]. Shijiazhuang: Ordnance Engineering College, 2010.