

THE CHARACTERISTICS OF COOLING ON HEAT SINK USING A CROSS FLOW SYNTHETIC JET ACTUATED BY VARIATION OF WAVE FUNCTION

HARINALDI, ARIEF RANDY, ALDY ANDIKA, DAMORA RHAKASYWI

Department of Mechanical Engineering
University of Indonesia
Kampus UI-Depok, Jawa Barat 16424
INDONESIA
harinald@eng.ui.ac.id

Abstract: - Synthetic jet which is based on zero netto mass input but non-zero momentum is a new approach utilized for cooling system. The synthetic air jet was generated by vibrating membranes which pushed out the air from the cavity through the exit nozzles with oscillatory motion. This research investigated the forced cooling characterization of a cross flow synthetic jet using double membrane actuator with two different variations of sinusoidal and square wave and was conducted in computational as well as experimental stage. Computational stage was conducted by a commercial CFD software of Fluent[®] with a turbulence model $k-\omega$ SST with meshing elements quad type pave, while in the experimental work the function generators was used to drive the membranes with the variation of sinusoidal and square wave in three oscillation frequencies i.e 80 Hz, 120 Hz, and 160 Hz at fixed amplitude of 0.002 m/s. The experimental results show significant effect of the reduction of the confinement effect phenomena by using the cross flow synthetic jet. The best heat transfer rate, hence the optimum cooling effect was obtained at a lower oscillation frequency; in this study at *sinusoidal 120 Hz – sinusoidal 120 Hz*.

Key-Words: - Cross Flow Synthetic Jet, Double Membranes, Confinement Effect, Heat Transfer Rate, $K-\omega$ SST

1 Introduction

Today's technologies in electronic devices need an improved cooling technology. Until recently, most common method to overcome heat of the devices is by using cooling system, such as fans and heat sinks. However, conventional fans have limitation in their dimensions, because the fans operate based on electromagnetic principle which requires a minimum space in order to assemble the coil. The new promising cooling system is to overcome these limitations of a cooling system based on the effect called "synthetic jet".

Synthetic jet is a fluid flow in the form of a series of vortex rings, which is formed due to the oscillatory movement of the membrane in a cavity [1]. Due to pulsating nature of the flow, the entrainment of ambient fluid into the jet is high as compared to that in a continuous jet, which helps in effective cooling [2].

Synthetic jet is driven by a piezoelectric actuator (membrane) and will create a zero-net mass input but produce a non-zero momentum output [3]. Visually, synthetic jet can be described as in Fig.1.

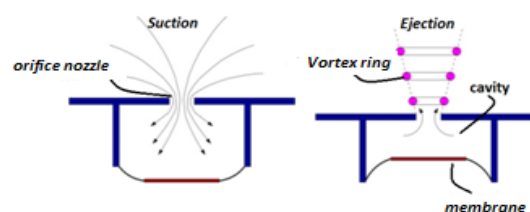

Fig.1 Sketch of the synthetic jet formation [3]

The synthetic jet forming process has been shown in some work which has been done by Jagannatha et al. [4] and Zhang & Tan [5]. The synthetic jet is formed as follows. Inside the cavity there is a diaphragm or membrane. Membrane will be moved periodically and form a vibration so that the air inside the cavity moves too. The air inside cavity is forced to move through two phases, namely suction and ejection. These two phases are formed due to the orifice on the side of the cavity. At the orifice exit flow separation occurs because of those two phases and forms a vortex ring pair. These vortex rings are used to produce convective heat

transfer effect that has better thermal control to the heat sink.

Synthetic jet is continuously developed because it has advantages over conventional cooling systems such as fan. For fan system, the need of air supply is filled by flow the air from one place to another. Synthetic jet system offers major advantages which only use the same air that continuously moving by the system [6]. Also refers to the amount of heat removed due to the volume of flow, fan is considered less efficient (Mahalingam et al. [7]). Another advantages of using synthetic jet cooling system compared with fans for the same heat transfer performance include [8]: Lower noise level, efficiency (thermodynamic) is much better, the need for power is only half or less, have a better form factor so it's "design-friendly", higher reliability, etc. Synthetic jet is divided into two models, impinging jet [9] and cross-flow jet [7].

Impinging and cross-flow models have a difference in the field of fluid flow direction. In impinging jet, the vortex flow is directed towards the heated wall so that the vortex flow hit the heated wall and then the vortex flow moving along the wall, while the cross-flow vortex which directs the vortex flows directly through the wall components and moving parallel to the wall. There are three main variables that affect heat transfer at the impinging synthetic jet such as excitation frequency, step length and height of the orifice toward the surface [10].

Synthetic jet has been investigated by many people, but the knowledge of the synthetic jet is still extremely limited. As in the study of synthetic jet by using a sinusoidal and non-sinusoidal wave studied [11] where they say that heat transfer coefficients show better result about 5-10% for the non-sinusoidal wave. Furthermore they have shown that research on synthetic jets using a non-sinusoidal wave is still lacking, although the use of non-sinusoidal waveform for synthetic jet heat transfer coefficients show better. Harinaldi [12] has proved, both computationally and experimentally, that the impinging type of synthetic jet could produce the cooling effect on the heat sink by using the modes variation of excitation

However, synthetic jet also has a weakness, especially for the impinging type. For the impinging type, the fluid is sucked back during the suction phase when membrane of synthetic jet oscillating. If the air is discharged at discharge phase and there is hot air is sucked back into the cavity, it will make accumulation of heat in the synthetic jet cavity [13]. Harinaldi [14] also reported that the confinement effect that occurs in impinging type of synthetic jet

will reduce the cooling effect and makes the optimum cooling period only happened in first 30 minutes of cooling period.

This research was conducted to find a formulation for improving and optimizing the process of synthetic jet cooling due to the confinement effect by using a cross flow type, and also to determine the duration of the optimum cooling period of the cross flow synthetic jet. Therefore, the use of another common wave like triangle and square needs to be done

2 Methods

The present investigation was done comprehensively by computational and experimental works. The prototype of synthetic jet actuator designed and used in the experiments is depicted in Fig.2 shows the detail of synthetic jet actuator, Fig.3 shows the heat sink detail, Fig.4 synthetic jet actuator and heat sink.

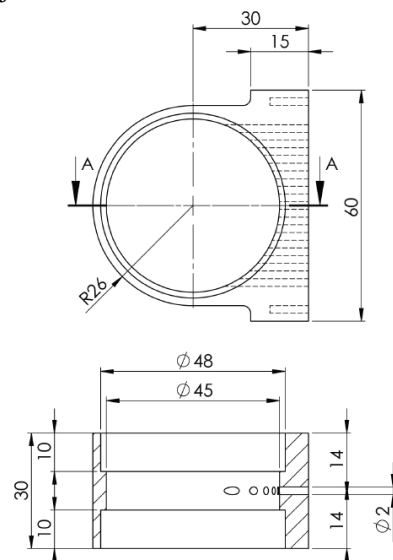

Fig.2 The detail of synthetic jet actuator

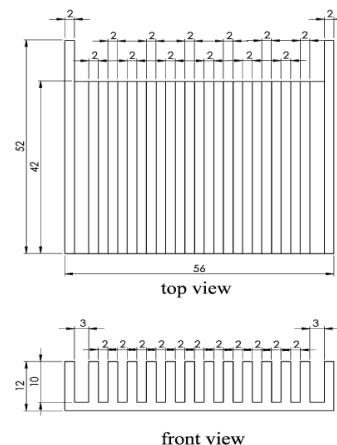

Fig.3 The heat sink detail

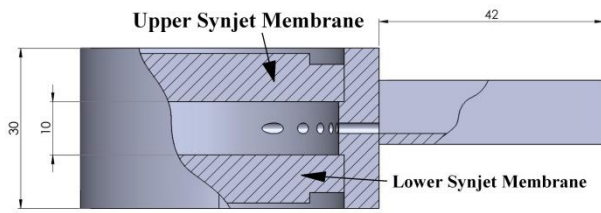

Fig.4 synthetic jet actuator and heat sink

The arrangement comprised a piezoelectric membrane that was set in motion back and forth forcing fluid inside the cavity to flow through a nozzle of synthetic jet. In its inward motion, the membrane imparted the ejected air of high-speed into the surrounding fluid while the retreating membrane drew fluid back from the surroundings into the cavity. The membrane operation over one cycle depends on the selected frequency. The jet delivered very high net outflow of fluid momentum, in the form of vortice train and consequently very intense cooling rates could be expected while having no net change of fluid mass within the cavity.

2.1 Computational Work

In this research, computational stage was conducted in order to get a picture of the flow and thermal fields on the cross flow synthetic jet configuration. The work was conducted by using GAMBIT 2.4 software to generate the grid as show in Fig.5 and FLUENT 6.3 for the computational solver. The computational model was derived from an originally designed synthetic jet actuator configuration along with the heat sink as the heated wall.

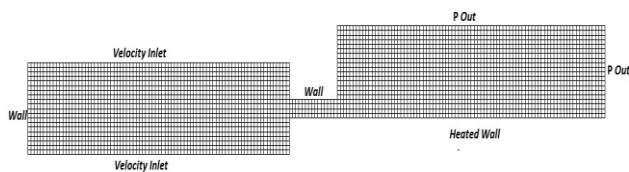

Fig.5 synthetic jet computational domains

The computational model used to analyze the thermal flow at synthetic jet adopted mathematical model of $k-\omega$ SST (Shear Stress Transport). The model use 2D Double Precision mode. The SST $k-\omega$ model is similar to the standard $k-\omega$ model, but includes some refinements [15].

The SST $k-\omega$ model has a similar form to the standard $k-\omega$ model as expressed (1) and (2).

$$\frac{\partial}{\partial t}(\rho k) + \frac{\partial}{\partial x_i}(\rho k u_i) = \frac{\partial}{\partial x_j} \left(\Gamma k \frac{\partial k}{\partial x_j} \right) + \tilde{G}_k - Y_k + S_k \quad (1)$$

$$\frac{\partial}{\partial t}(\rho \omega) + \frac{\partial}{\partial x_i}(\rho \omega u_i) = \frac{\partial}{\partial x_j} \left(\Gamma_\omega \frac{\partial \omega}{\partial x_j} \right) + G_\omega - Y_\omega + D_\omega + S_\omega \quad (2)$$

Where the constants:

$$\alpha_\infty^* = 1, \quad \alpha_\infty = 0.52, \quad \alpha_0 = \frac{1}{9}, \quad \beta_\infty^* = 0.09, \\ \beta_1 = 0.072, \quad R_\beta = 8, \quad R_\xi = 6, \quad R_\omega = 2.95, \quad \zeta^* = 1.5, \\ M_{t0} = 0.25, \quad \sigma k = 2.0, \quad \sigma \omega = 2.0$$

The parameters used at this simulation include model arrangement, fluid properties and the boundary conditions. Ambient temperature was assumed 27 °C and the temperature at the bottom of heated wall was maintained at isothermal condition of 60 °C. Boundary walls on both sides of the actuator were assumed to have a constant static pressure with a pressure of 1 atm. Other details of computational conditions are written in Table 1.

TABLE 1. Computation Condition

Computation Condition		
Model Settings	2D, Unsteady	
Fluid	Air	
Fluid Properties	Density	1.225 kg/m ³
	Viscosity	1.7894 e ⁻⁵ kg/m-s
	Specific Heat	1006.43 J/kg-K
	Thermal Conductivity	0.0242 W/m-K
Boundary Condition	Velocity Inlet 1,2	UDF
	Pressure Outlet (Gauge Pressure)	0 Pascal
	Heat source	60 °C
	Frequency Excitation	80 Hz, 120 Hz and 160 Hz
	Excitation Amplitude	1 m/s

Furthermore, the movement of the diaphragm was modeled with a user defined function (UDF). In this model, at the beginning ($t = 0$), the position of the diaphragm is at the bottom of the cavity. The diaphragm movement was assumed equal to the movement of the piston in a cylinder. The upper membrane was oscillated with sinusoidal wave, which the velocity function is expressed below:

$$V = V_0 + A \sin(2\pi f) t \quad (3)$$

Meanwhile the bottom membrane was oscillated with a square wave, which the velocity function is expressed below:

$$V = V_0 + \frac{A}{\pi} \sum_{n=1,3,5,\dots}^{\infty} \frac{1}{n} \sin(n\pi f) t \quad (4)$$

Where A is the maximum speed which was formed due to the movement of the diaphragm inside the cavity, t is the time progress of membrane fluctuation and V_o is the initial velocity .

2.2 Experimental Work

Experiment stage was conducted to obtain temperature data of a heat sink which was cooled using synthetic jet. Experimental setup of the present study is described in Fig.6. Data was collected by measuring the temperature of the heat sink at six points as described in Fig.7 by using data acquisition module (Advantech 4718) with an accuracy of measurement ± 0.01 °C. Prior to the experiment, a heat sink temperature setting was performed. Heat source at the heat sink was obtained by placing the heater mat at the bottom of the heat sink with a regulated temperature of 60 °C using a thermostat and measurements was performed at ambient temperature of 27 °C and ambient humidity is 70% - 84%. Furthermore, a two-channel function generator was used to excite sinusoidal and square wave signals to upper and lower membrane respectively with excitation frequencies of 80 Hz, 120 Hz and 160 Hz. The temperature data were picked by thermocouples at six points on the heat sink through the DAQ which connected with a computer. Data retrieval in this experiment was carried out for 1 hour at data rate of 1 Hz.

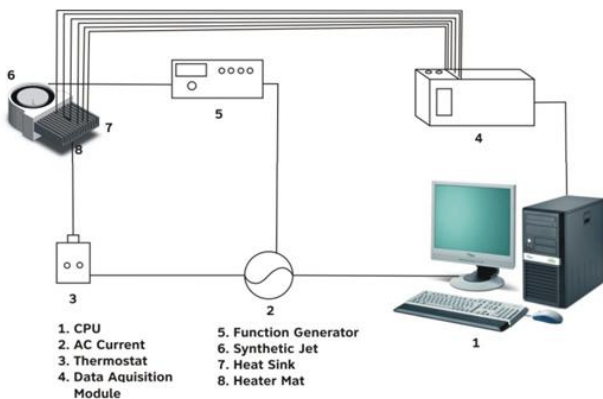

Fig.6 Experimental Set-up

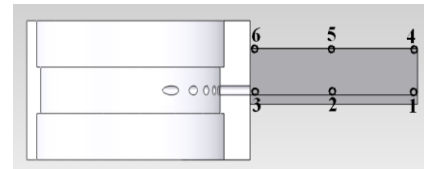
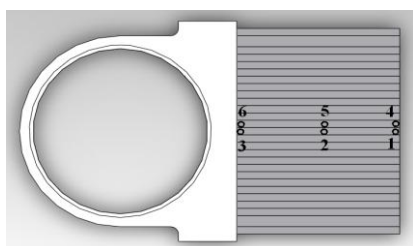

Fig.7 Points of temperature measurement

3 Results and Discussion

3.1 Computational Stage

Computational stage is done by analyzing the temperature, velocity, and turbulence intensity contour by performing the flow simulations.

3.1.1 Temperature Contour

The analysis of temperature contours are used to elucidate the cooling effect of the heat sink by a synthetic jet produced by two membranes that driven by sinusoidal and square function during one period. By using this analysis, we can see the evolution of the contours of temperature changes and movement of cooling flow in the heat sink.

Series of pictures in Fig.8 show the change of temperature during the process of cooling by the synthetic jet. It can be seen that after a quarter of the cycle for both sinusoidal and square wave at all frequency, the low temperature air starts to flow from the nozzle of synthetic jet actuator and extends to the heat sink to create the cooling process. When the phase has reached the half of the cycle, the cooling effect continues and spreads throughout the heat sink until one full wave. The simulation also shows that the difference of frequency and excitation are greatly affecting the cooling effect that occurs on the heat sink. As seen in the Fig.6, the sinusoidal has a better cooling effect than the square wave, and the result also reveals that the lower frequency appears to demonstrate the better cooling effect than the higher frequency

This cooling effect will continue until a stagnant condition in which the temperature difference between ambient and around synthetic jet actuator is almost equal and the cooling effect is no longer effective. This stagnant condition, where the accumulation of hot air in the cavity happened, is called as confinement effect. Further observation discussed latter indicates that the effect of confinement effect in cross flow jet is not as much as occurred in impinging jet type.

3.1.2 Turbulence Intensity

Characteristics of turbulence intensity level during a complete cycle can be seen in the series of contour plots at the Fig.9. In the Fig. it can be observed the

turbulence intensity variation from a phase to another phase. At quarter of the cycle the maximum intensity of turbulence occurs and the most intense turbulence occurs on the orifice. This is due to a sudden change of momentum of the air flow air in the cavity which is initially calms. However, the levels of the turbulence intensity in orifices continue to decrease in the next phase until the end of a wave. Although the intensity of turbulence decreases at the

nozzle after quarter of the cycle, the distribution of turbulence with high intensity has already spread to the area around the heat sink. This spread will occur continuously as the number of waves increase as the cooling process progresses. At first peak (quarter cycle) the turbulence starts entering and spreading into the heat sink, and at the end of one full cycle, the turbulence has spread to the sides of heat sink. According to the result of the simulation, we can see

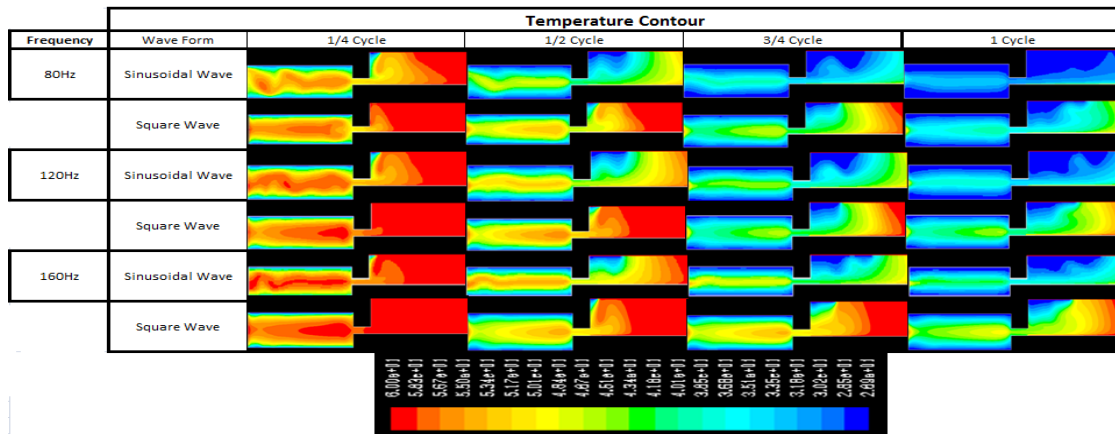

Fig.8 Temperature Contour

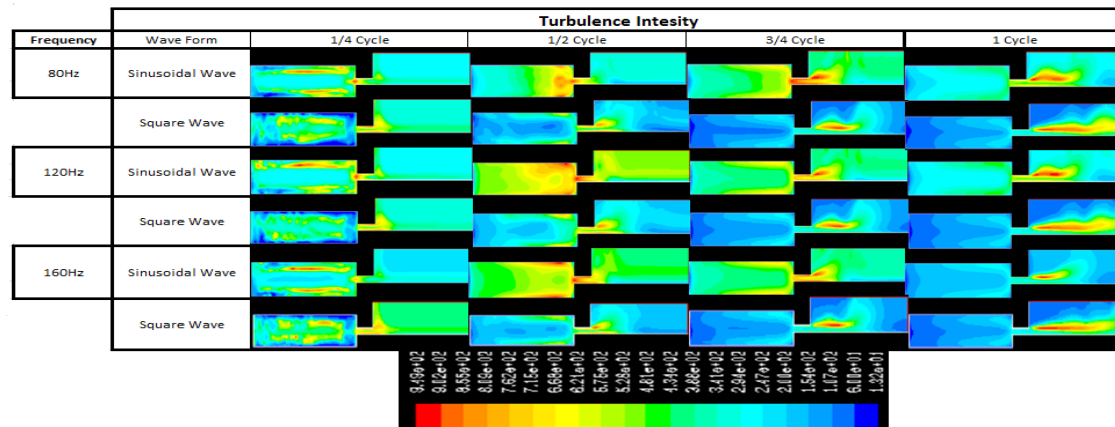

Fig.9 Turbulence Intensity

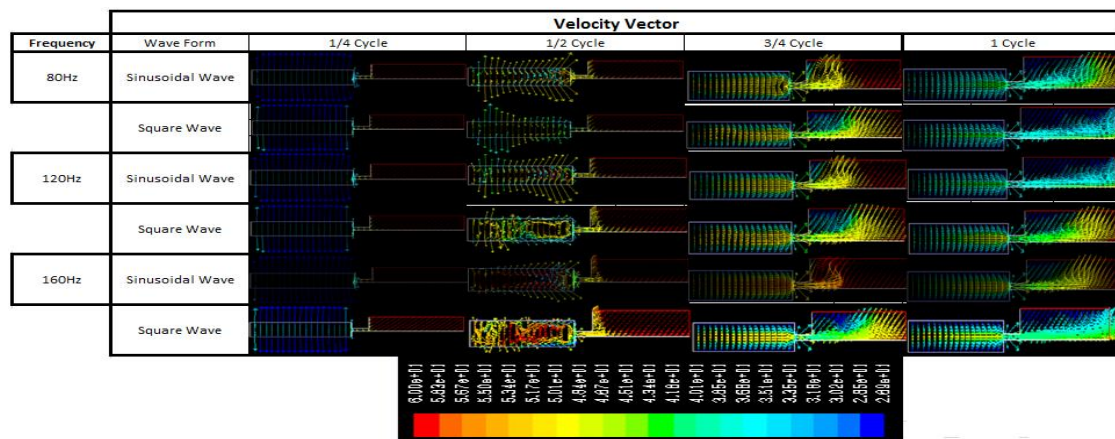

Fig.10 Velocity Vector

that the sinusoidal wave has the higher value of turbulence for all frequency rather than the square wave.

3.1.3 Velocity Vector

In Fig.10 series of velocity vector plots indicate the dynamics of the flow field during a cycle of synthetic jet operation for all frequency and excitation. A significant increase of the velocity of the air flow from the synthetic jet cavity towards the heat sink through the nozzle can be seen in the first quarter of the cycle. The movement of fluid then propagates into heat sink continuously with the increase of velocity. At the third quarter of the cycle the movement of the air flow has arrived at the side of the heat sink evenly and after a complete cycle the flow of low temperature air rises to all side of the heat sink. This flow field dynamic indicates that synthetic jet flow will be more effective for cooling after a certain time period since the synthetic jet flow was initiated

3.2 Experimental Stage

Temperature data obtained in the six points of measurement at the heat sink generally show similar characteristics and trend in every points. Hence, in the following paragraphs only the data series taken at three points (point 1 at end of the heat sink channel, point 2 at halfway of the heat sink channel and point 3 at near to the nozzle exit) which will be discussed in detail to represent results at other points. The results are presented and analyzed into two kinds of graphs, specifically temperature changes versus time and convective heat transfer coefficient versus time.

3.2.1 Temperature history of the heat sink

Fig.11 shows the temperature history of the heat sink at point 3 (near to the nozzle exit) being cooled by the synthetic jet for 60 minutes with all combination of excitation mode of the two membranes. From Fig.10 it is observable that a rapid decrease of heat sink temperature takes place from the beginning of cooling process until the minimum temperature is achieved and then the temperature slightly rebound to increase. For all excitation variations it can be understood that the temperature decreases are remarkably seen for the first 30 minutes.

Meanwhile at half way of the heat sink channel (point 2) as shown in Fig.12, it appears that the variation of synthetic jet wave excitation still significantly give impact to the reduction of temperature on the heat sink, but no longer show a

tendency of such rapid temperature drop like at the start of cooling process begin.

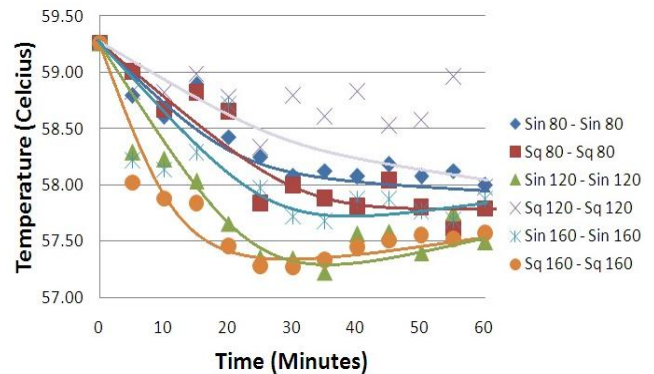

Fig.11 Temperature history of the heat sink at point 3 being cooled by the synthetic jet within period of 60 minutes

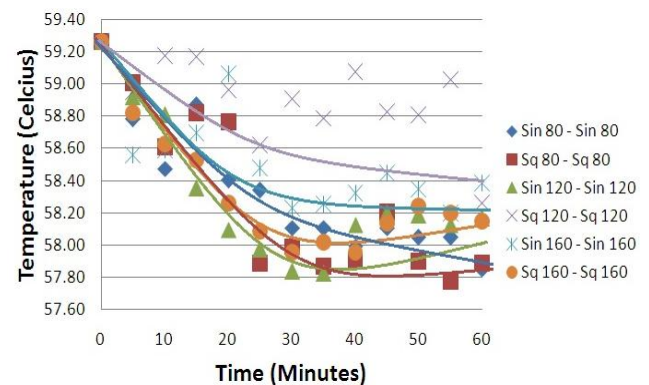

Fig.12 Temperature history of the heat sink at point 2 being cooled by the synthetic jet within period of 60 minutes

Moreover, in Fig.13 shows the result of heat sink measurement at the farthest point from the nozzle (point 1), it is obvious that the influence of the

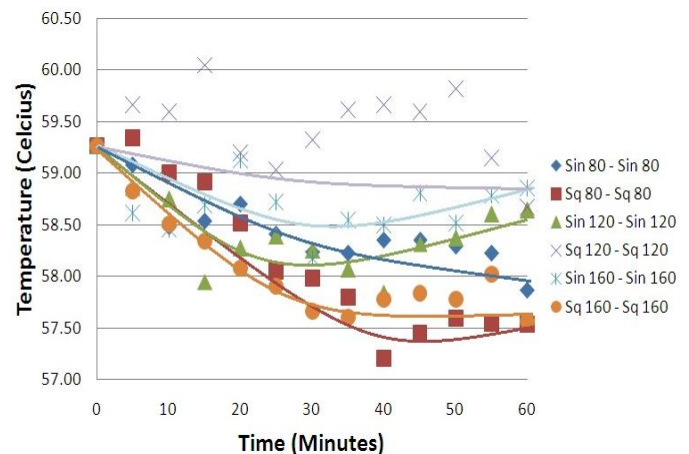

Fig.13 Temperature history of the heat sink at point 1 being cooled by the synthetic jet within period of 60 minutes

distance from the nozzle result in a decrease of cooling effect produced by the synthetic jet, as indicated by relatively small temperature drop compared to the temperatures drop at point 2 and 3.

Closer looks at the above three figures reveal that the variation of sin 120 Hz - sin 120 Hz appears to demonstrate the best cooling effect suggested by the decrease of the temperature of the heat sink up to 2.04°C, which is then followed by a 160 Hz square - 160 Hz square wave variation with temperature drop up to 1.99 ° C. The lowest cooling rate is produced by the variation of sin 80 Hz - sin 80 Hz with the temperature drop of 1.26°C.

After an optimum cooling period of 30 minutes, there seems no significant variation of temperature change which indicates the heat transfer has reached its equilibrium condition. This result shows that the cross-flow synthetic jet cooling method experienced less the confinement effect or the effect of chaff which means that the effectiveness of this cooling period is better and longer.

This is in contrast with the results of our previous experiments on impinging synthetic jet [14]. Fig.14 shows the comparison between the performance of impinging synthetic jet and cross-flow synthetic jet, which indicates a trend of increasing in temperature if the synthetic jets continue to operate beyond the optimum cooling period due to the confinement effect in impinging synthetic jet.

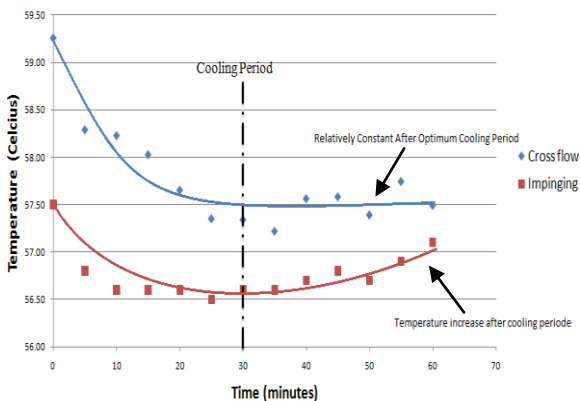

Fig.14 The comparison of performance between impinging synthetic jet and cross-flow synthetic jet at sinusoidal 120 Hz – sinusoidal 120 Hz

3.2.2 Convective heat transfer characteristics

Fig.15 shows the characteristics of heat transfer coefficient with respect to time for all combination of excitation mode of the two membranes. The determination of heat transfer coefficient has been discussed in detail in other report [16]. The Fig. indicates that it takes a time for the system to achieve stability of the heat transfer coefficients at various frequencies of synthetic jet. However, a

similar tendency is remarkably observed. All heat transfer coefficient plots show the trend of increasing heat transfer coefficients at the initial stage of cooling. The heat transfer coefficients rise to peak values, slightly decrease and the trend to be constant at around 25-30 minutes after the membranes vibrating.

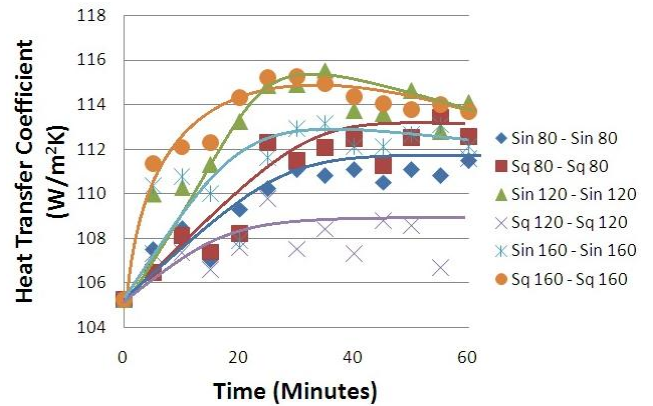

Fig.15 Convective heat transfer coefficient under synthetic jet blowing with sinusoidal - square wave forcing

The highest value of heat transfer coefficient is obtained at the combined excitation of sinusoidal 120Hz – Sinusoidal 120Hz where the heat transfer coefficient up to 115.53W/m²K is achieved at the peak after the cooling process in 30 minutes. On the other hand, the combined excitation of square 120Hz – Square 160Hz gives the worst performance of cooling. The heat transfer coefficient is relatively low and even after 60 minutes of the synthetic jet operation, the heat transfer coefficient is lower than its initial value. It seems that the accumulation of hot air in the cavity of synthetic jet is more pronounced in this combined excitation mode.

4 Conclusion

The investigation of flow and cooling characteristics on heat sink using a cross flow synthetic jet by combined excitation mode has been done. A synthetic jet actuator originally designed with double piezoelectric membranes is oscillated using the combination of excitation sinusoidal wave for upper membrane and square wave for bottom membrane at various frequencies (80Hz, 120Hz, and 160Hz). Computational and experimental works have been carried out and have successfully demonstrated a promising cooling effect on the heat sink.

The results showed that the cross flow synthetic jet could reduce the confinement effect which

occurred in impinging synthetic jet. The suction and discharge of the synthetic jet membrane due to the oscillation frequency plays an important role in the cooling process. The different modes of excitation in membrane as well as the different frequency affect the characteristics of thermal, flow and turbulence field alteration which eventually give significant influence to the rate of heat transfer obtained. Among all the combined excitation modes investigated in the current the best cooling effect is occurred at the combined excitation of sinusoidal 120Hz – sinusoidal 120Hz which gives heat transfer coefficient of 115.53 W/m²K and decreasing the temperature of the heat sink cooling up to 2.04°C and.

References:

- [1]. B.L Smith, A. Glezer, *The Formation and Evolution of Synthetic Jets*. Physics of Fluid 10, 1998, pp. 2281-2297
- [2]. M. Chaudhari, B. Puranik, A. Agrawal, *Heat transfer characteristics of synthetic jet impingement cooling*, International Journal of Heat and Mass Transfer , heat mass transfer. 2009.11.005.
- [3]. Krishnan, Gopi., Mohseni, Kamran. *An Experimental Study of A Radial Wall Jet Formed by the Normal Impingement of A Round Synthetic Jet*. European Journal of Mechanics B/Fluids 29, Elsevier Ltd, 2010, pp. 269-277
- [4]. Jagannatha, D., Narayanaswamy, R., and Chandratilleke, *Performance Characteristics of A Synthetic Jet Module For Electronic Cooling*, The 10th Heat Transfer Conference in International Symposium On phase Change, UK, 2007 pp. 8 – 9
- [5]. Zhang, J.Z., and Tan, X.M., *Experimental study on flow and heat transfer characteristics of synthetic jet driven by piezoelectric actuator*, Science in China Series E: Technological Sciences, vol. 50, 2007 pp. 221-229
- [6]. Sharma, R.N., *Some insights into synthetic jet actuation from analytical modelling*, The 16th Australasian Fluid Mechanics Conference, December 2007 pp. 1248
- [7]. Mahalingam, R., Heffington, S., Lee, J., and Schwickert, M., *Newsy server processor cooling augmentation using synthetic jet ejectors*, IEEE, 2006, pp. 705-709.
- [8]. Lasance, C.J.M., and Aarts, R.M., *Synthetic jet cooling part I: Overview of heat transfer and acoustics*. The 24th IEEE SEMI-THERM Symposium, 2008 pp. 20
- [9]. Persoons, T., O'Donovan, T.S., & Murray, D.B. (2008, July). *Improving the measurement accuracy of PIV in a synthetic jet flow*. Paper presented at the 14th International Symposium on Applications of Laser Techniques to Fluid Mechanics, Lisbon, Portugal.
- [10]. McGuinn, A., Persoons, T., Valiorgue, P., O'Donovan, T.S., and Murray, D.B. (2008). *Heat transfer measurements of an impinging synthetic air jet with constant stroke length*. Paper presented at the 5th European Thermal-Sciences Conference, Netherlands. Pp 6 – 8
- [11]. King, S. J. C. And Jagannatha, D., *Simulation of synthetic jets with non-sinusoidal forcing for heat transfer applications*, proc. 18th World IMACS / MODSIM Congress, Cairns Australia, 2009 pp. 1736 – 1737
- [12]. Harinaldi, Damora Rhakasywi & Rikko Defriadi, July 2011, *The Effect of Oscillation Mode To The Temperature Distribution of a Heated Wall Impinged by a Synthetic Jet*. The International Conference On QiR (Quality in Research). ISSN 114-1284.
- [13]. Tesar, V, Chuan, H.H., and Zimmerman, W.B., *No-moving-part hybrid-synthetic jet actuator*. SNA-4850, 2005, pp. 1-11
- [14]. Harinaldi, Defriadi, R., Rhakasywi, D., *Effect of Cavity Design of Synthetic Jet Actuator to the Heat Transfer Characteristic of an Impinging Flow Configuration*. Int. Review of Mechanical Engineering, vol. 7, 2012
- [15]. P. Mane, K. Mossi, A. Rostami, R. Bryant, N. Castro, *Piezoelectric actuators as synthetic jet: cavity dimension effects*, J. Intelligent Mater. Syst. Struct. 18 (2007) 1175.
- [16]. Harinaldi, Defriadi, R., Rhakasywi, D., *Flow and Heat Transfer Characteristics of an Impinging Synthetic Air Jet under Sinusoidal and Triangular Wave Forcing*, International Journal of Engineering & Technology IJET-IJENS Vol: 11 No: 03, pp. 6-7