

# Weighted Multi Objective Index Based Placement of Power Quality Disturbance Mitigating Devices in DG Environment

VISHWANATH G.  
Research Scholar at VTU  
Department of EEE  
Belagavi  
INDIA  
Vishwanathg@nieit.ac.in

LOKESH M.  
NIEIT  
Department of EEE  
Mysuru  
INDIA  
Lokesh@Nieit.ac.in

MOHAN N.  
JSS Science and Technology University  
Department of EEE  
Mysuru  
INDIA  
Mohannachar@gmail.com

A. D. KULKARNI  
NIE  
Department of EEE  
Mysuru  
INDIA  
Nieadk@gmail.com

*Abstract:* In recent years, the Electrical Distribution system is operated with the integration of various Distributed Generators close to its working limits. Some of the D-facts devices such as D-STATCOM, DVR, and UPQC are placed in the Distribution system to enhance the power quality and to improve the overall stability of the system but the placement of these D-Facts devices in DG environment is essential for the overall power quality improvement. In this paper, a novel technique is introduced based on weighted multi-objective function with power quality indicators for finding the most sensitive bus concerning power quality disturbance in the Distribution system. The optimal sensitive bus is identified for integration of Power quality disturbance mitigating devices with Rotating and Static Distributed Generators.

*Key-Words:* Distributed system, Weight values, Static and Rotating Distributed Generation, Voltage Quality Index, Deviation Index, Weighted Multi objective Power Quality Index [WMOPQI].

Received: January 16, 2018. Revised: March 23, 2020. Accepted: April 27, 2020. Published: May 21, 2020.

## 1 Introduction

In the coming years, there will be a significant advancement in renewable energy sources such as solar PV systems which are connected to the electricity grid. This grid-connected solar panel provides power during day time and the extra electricity is stored in batteries or fed back to the electrical grid network [1]. The pros of the grid-connected PV system are low operating cost, reduction in electricity bills and maintenance costs. The downside is to install a large number of solar panels that are required to generate surplus power. Hence the Diesel generator is used for immediate or sudden load demand since it is easy to install and requires low space and commonly available in the market as per requirements. The diesel generator is a preferred choice even when diesel fuel cost is high as per Kwhr. Similarly, the integration of wind farm to the grid is increasing day by day and when large integration of wind generators to the utility grid then its dynamics and operations get affected [2]. Fuel Cell, on the other hand, is very efficient and low emission levels. It operates or supplies electricity by combining oxygen and hydrogen electrochemically without combustion. The Fuel cell produces DC voltage and converted to AC voltage using inverters and then power is delivered to the Grid [3], [4]. The power quality standards are set by the

Institute of Electrical and Electronics Engineering (IEEE) and the Bureau of Indian Standards (BIS) has set up a technical committee, ET-45, to formulate power quality standards. The power quality improvement in a Distribution system is possible only by detecting the node or bus having maximum distortion and balancing the voltage and frequency at that node concerning the load demand is essential [8]. For optimal placement of Distributed Generator in a Distribution system many optimization techniques are introduced such as particle swarm optimization (PSO), firefly algorithm, weighted technique, bat algorithm (BA) and cuckoo search method (CS) [5]. The weighted sum method was introduced by Zadeh (1963) to provide a Pareto optimal set. However the significance of weight is not explored, there is a different algorithm for selection of weight values for a particular function, but there are no proper fundamental steps for selection of weight. The Ratio weighted value and paired Comparison methods were implemented by Saaty (1977 to 2003), which involves  $x(x-1)/2$  pairwise comparison between objective function. Many authors [1992-2005] pointed weighted Methods inability to capture Pareto optimal solution points, continues change in weight values and drastic change between consecutive solution points. The above three deficiency was overcome as alternative methods which are valuable and effective exist but they are

independent of weighted sum method [6]. In [7], 2011 Zhou Hui and Yang Hongegeng applied [AHP] Analytical Hierarchy process and PCA Principal component Index on Comprehensive evaluation of Power quality and PCA significantly reduces the amount of calculation and retained most information of original data with effective reduction of Dimension in data. [8] Wei Chen and Xiaohong Hao considered both objective and subjective methods for power quality evaluation using the Fuzzy system. [9] Naik R.L and Suresh implemented weighted total harmonic distortion for power quality analysis for VSI in WECS [2014]. THD values of Converter, Grid for two levels and three levels of (VSI) are reduced to the acceptable values of IEC 10000 3-4 regulations [10]. A weighted multi-objective Index is derived for optimal distribution planning in the distribution system, The major objective of this work was voltage improvement, location and allocation of distributed generation with variable DG Penetration levels [11]. In this paper, the sensitive bus is identified based on the maximum disturbance of Power quality indicators with weighted multi-objective function value. The Power quality Index and Weighted Multi-Objective is combined to form an Index know as Weighted Multi-Objective Power Quality Index(WMOPQI). The prime objective of the Index is to find the Sensitive bus for the placement of Facts Devices. Sub objective is to improve voltage at all buses and reduce line losses. A Simulation approach is selected for the finding the sensitive bus, IEEE 5 bus test system is modeled with rotating type and static type distribution generations.

## 2 Weighted Multi-objective optimization Technique with Power quality Deviation Index

### 2.1 Multi-objective optimization Technique

Multi-objective optimization is also known as Pareto optimization or multi objective programming. It is widely used in the area of power system and the multi objective optimization problem is an optimization problem involving multiply objective function

The Mathematical formulation is given by

$$\min [f_1(x), f_2(x), \dots, f_k(x)] \quad (1)$$

Subject to  $x \in X$

Where the integer  $k \leq 2$  is the number of objective and the set  $X$  is the feasible set of Decision

vectors. To maximize objective function then its equivalent value is minimized to negative. An element  $x * X$  is called a feasible solution. A vector  $Z^* = f(X^*) R^k$  for a feasible solution  $x^*$  is called an outcome or objective vector. This technique doesn't minimize all objective function to provide a feasible solution. A Pareto dominate is obtained when a solution that can't be improved without degrading at least one other objective function. A solution  $x * X$  and the corresponding outcome is called Pareto optimal solutions (Fig. 1).

### 2.1.1 Weighted Multi-objective optimization technique

$$U = \sum_{i=1}^k \quad (2)$$

$$\nabla_x * P[f(x)] = \sum_{i=1}^k \frac{\partial P}{\partial F_i} * \Delta_x * F_i(x) \quad (3)$$

$$\nabla_x * U = \sum_{i=1}^k w_i * F_i(x)$$

Each component of the gradient  $\nabla * P$  qualitatively represents how the decision-makers satisfaction changes with a change in the design point and a consequent change in function values.

The weights represent the gradient of U in (3) with respect to the vector function F(x), shown as follows:

$$\nabla_F = \begin{bmatrix} \frac{\partial U}{\partial F_1} \\ \frac{\partial U}{\partial F_2} \end{bmatrix} \quad (4)$$

Objective function with weight Consideration

$$U = W_1 * F_1(x) + W_2 * F_2(x) \quad (5)$$

For U to have a minimum, it is necessary that the gradient of U be equal to zero, as follows

$$\nabla_x * U = W_1 * \nabla_x * F_1 + W_2 * \nabla_x * F_2 \quad (6)$$

### 2.1.2 Deficiency in weight system

The weight value and Preferences are the two important parameters to obtain an accurate solution. The preference function is considered based on the arbitrary or systematic selection of weight value concerning decision-maker which may or may not

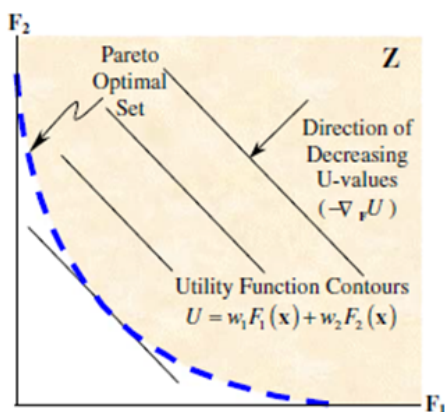

Figure 1:  
Pareto optimal set in the criterion space

be a required output. From the equation (3) the gradient  $\nabla XP$  represents the change in the decision maker's satisfaction with a change in design point and the consequent change in function values. A utility function is a linear approximation (in the criterion plane) of the preference function. The gradient of the utility function is parallel to the gradient of preference function if the weights are properly selected. The value of weight is significant not only relative to other weights but also relative to its corresponding Objective function. Hence the process of selecting weights and thus indicating preferences are complicated.

## 2.2 Importance of Power quality Indicators in Deviation Index

The quality of power supplied by a utility to electricity consumers depends on the availability of supply, Voltage magnitude, and frequency. At steady-state values of voltage and frequency with smooth sinusoidal waveform supplied by the network is considered as good power quality. Some of the problem faced by poor power quality is due to varying electrical demand and faults cause a disturbance in the distribution system which impact in deviation from normal Characteristics. To access the power quality of a Distribution system the major parameters considered are frequency (Hz), Voltage (V), real power (KW) and reactive power (Kvar). So it is important to evaluate the power quality of a distribution system not just based on voltage and frequency but also on other power quality indicators.

### 2.2.1 Frequency Deviation ( $\Delta f$ )

It is defined as the change of supply frequency from the constant value.

$$\Delta F = \sum_{i=0}^{nloadbus} (f_{ref} - f_{actual}) \quad (7)$$

### 2.2.2 Voltage Deviation ( $\Delta V$ )

Voltage deviation is defined as the difference between a reference voltage and operating voltage at a point in the distribution system

$$\Delta V = \sum_{i=0}^{nloadbus} (V_{ref} - V_{actual}) \quad (8)$$

### 2.2.3 Real Power Deviation ( $\Delta P$ )

Real power Deviation is defined as the difference between the real power load connected at  $i$ th bus and actual real power flow at the  $i$ th bus in a distribution system.

$$\Delta P = \sum_{i=0}^{nloadbus} (P_{load(i)} - P_{actual(i)}) \quad (9)$$

### 2.2.4 Reactive Power Deviation ( $\Delta Q$ )

It is defined as the difference between the Reactive power loads connected at  $i$ th bus and actual Reactive power flow at the  $i$ th bus in a distribution system

$$\Delta Q = \sum_{i=0}^{nloadbus} (Q_{load(i)} - Q_{actual(i)}) \quad (10)$$

## 3 Problem formulation

The integration of Different Distribution Generation technology [3] at a different bus in the distribution system results in a deviation of basic power quality parameters that need to be addressed. The behavior of Distribution generation, when connected to a static load compared to an Induction motor load, are to be studied. The type and location, [5], of Distributed Generation play a very important role in the distribution system (Fig. 2).

1. The Voltage Stability Index is not sufficient for identifying the location of DG integration [5].
2. The Necessity to study the impact of the type of DG on distribution system [12], [13].

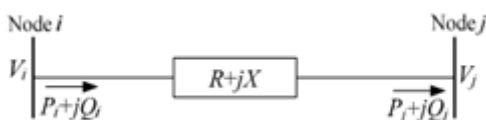

Figure 2:

Two bus systems connected with Distributed line

- From [6] and eq(5) it is clear that identifying the weights for the given system is complicated and the observed output result can not be verified. The sensitivity of the bus depends on voltage and losses in the distribution system [11]. It may also depend on Frequency, real power flow, and reactive power flow.
- Weighted Multi objective Power quality Index equation is represented below.

$$WMO(PQI) = \sum_{i=0}^m \frac{W_1 * \Delta F + W_2 * \Delta V + W_3 * \Delta P + W_4 * \Delta Q}{W_1 + W_2 + W_3 + W_4} \quad (*)$$

## 4 Methodology

The suitable location and maximum number of fixed size Distributed generators Can be integrated to the distribution system to improve voltage stability and the result is obtained by using Simulation method. In this work, Modeling of Radial distribution system and Distributed generators is carried out in Matlab/Simulink software package. The steps as followed (Fig. 3):

- STEP 1: Modeling of IEEE 5 Bus radial distribution system in MATLAB/SIMULINK with Static RL loads and Induction motor load.
- STEP 2: To simulate the test system to find Bus voltage, Real and Reactive power flow, Real and reactive power losses and VQI at each bus.

– VQI-Voltage Quality Index:-

A single line diagram of DS is represented in Fig. 3 given below:

$$P_{loss} = \frac{P_i^2 + Q_i^2}{V_j} * R \quad (11)$$

$$Q_{loss} = \frac{P_j^2 + Q_j^2}{V_j} * X \quad (12)$$

where

$P_i, P_j$  - real power injection at node i and j.

$Q_i, Q_j$  - reactive power injection at node i and j

$V_i, V_j$  - voltage at node i and j

$R, X$  - are the resistance and reactance of the branch connecting nodes i and j.

$$VQI = 2 * V_i^2 - V_j^4 - 2 * V_j^2 * (P_j * R + Q_j * X) - Z^2 (P_j^2 + Q_j^2) \quad (13)$$

"The minimum VQI value is considered for the integration of Distribution system and VQI close to 1 Value is considered a quality voltage bus or less Sensitive voltage bus".

- STEP 3: At Least VQI Bus Connect 500KVA Diesel Generator and Simulate the test system.
- STEP 4: Obtain the simulation results and find the Least VQI Bus for the placement of next 500KVA Diesel generator.
- STEP 5: After the placement of Second diesel generator simulate the test system and record the values of VQI and line Losses.
- STEP 6: Continue the placement of DG's until the line losses are minimized.
- STEP 7: Note down the number of DG's placed and their locations.
- STEP 8: Create various faults such as LG, LL, LLL and LLLG faults at bus 2 to bus 5. Calculate the deviation of frequency, voltage, real power flow and reactive power flow from equation (7), (8), (9) and (10).
- STEP 9: Select the fault which provides maximum deviation value and convert the value in percentage for  $\Delta F, \Delta V, \Delta P$  and  $\Delta Q$ . Find the Normalizing factor  $\alpha$  for the above parameters.
- STEP 10: Weighted Value from the above step is Identified as  $W_1, W_2, W_3$  &  $W_4$ . By this method we have over come the problem of Weigh value and preferences from equation (6)
- STEP 11: run the simulation under normal condition and obtain the Power quality Deviation Index values and substitute the value in the equation (\*).

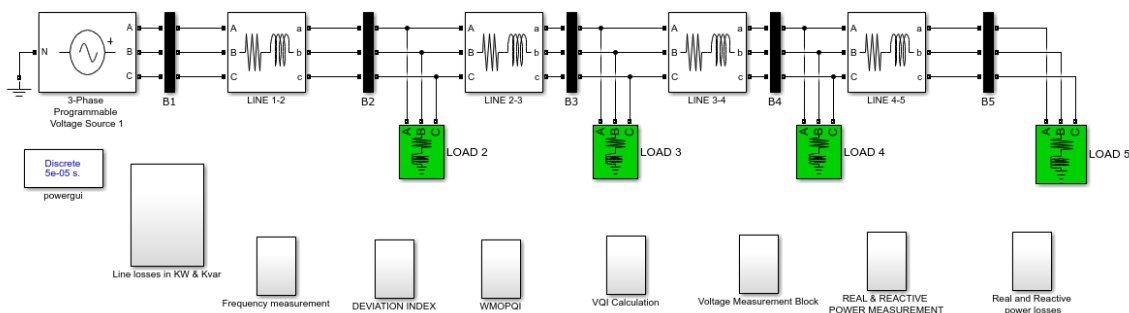

Figure 3: IEEE 5 Bus Test System in Matlab Simulation

- STEP 12: The maximum value obtained from above WMOPQI Index indicates the most sensitive bus.
- STEP 13: Repeat the procedure from Step 3 to step 12 by integrating Rotating DG with RL and Induction Motor Load.
- STEP 14: Compare the Result obtained in each case for Static and Rotating Distributed generator with Static RL load and Induction Motor load.

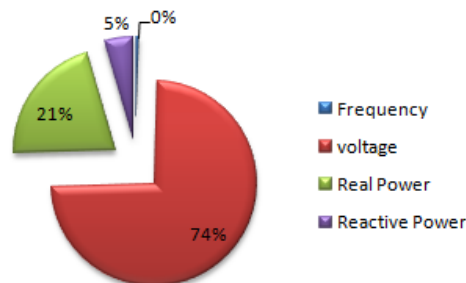

Figure 4:

Deviation Index for Diesel Generator with RL load

## 5 Result and Discussion

Generally, IEEE 5 bus system is a radial distribution system which is operated in voltage level of 11kV. This IEEE 5 bus RDS has 5 bus and 4 branches as shown in Fig. 3. The total reactive and active loads of the 5 bus test system are 1300 KW and 430 Kvar respectively. The Fig. 7 shows the single line diagram of 5 bus RDS. For the RL load the real power and Reactive Power Losses are 26.75KW and 10.19 KVar and For the induction motor Load the line losses are 51.25KW and 22.11KVar.

From Table 1 the distributed generation are classified into 2 types based on real and Reactive Power support

SL NO	Distributed Generation	Type of DG	Description
Type-1	Diesel generator	Rotating Type	Provides Real and Reactive Power Support
Type-2	Solar PV Generator	Static Type	Provide only real Power Support

Table 1: Types of Distributed Generation

### 5.1 CASE 1: Integration of Diesel Generator in Distribution System

In case A the Diesel generator is integrated into the IEEE 5 bus test system Under RL load and IM load. Fig. 4 and Fig. 5 indicate the maximum percentage deviation is considered Power Quality parameters possible for the given test system under the rotating Distributed generation environment.

### 5.2 CASE 2:- Solar PV Generation

Similarly to the above case A, The Solar PV Generators are integrated into the test system Under RL load and Induction Motor load. Fig. 6 and Fig. 7 indicate the maximum Percentage Deviation Possible for the considered power quality parameters in the given test system under Static Distributed Generation Environment.

The power quality Indicators selected are Voltage Deviation, frequency Deviation, Real power flow Deviation, and Reactive Power flow Deviation. From Fig. 4, Fig. 5, Fig. 6 and Fig. 7 it is observed that the frequency deviation with various faults is negligible compared to other Power quality indicators. The voltage deviation has maximum impact due to faults or Disturbances

Generator Type , Size and Location				
Types of Generator	Rating	Type of Load	Number of DG required	DG connected at Bus based on VQI
Diesel Generator (Rotating DG's)	500KVA	Static RL load	03	Bus5-DG1,Bus4-DG3,Bus3-DG2 and Bus5-DG1,Bus4-DG2,Bus3-DG3 and DG4,Bus2-DG5
	500KVA	Induction motor	05	
Solar PV (Static DG)	500KW	Static RL load	02	Bus5-PV1,Bus4-PV2 and Bus5-PV1,Bus4-PV2,Bus3-PV3
	500KW	Induction motor Load	03	

Table 2: The data of Distribution Generation, Location and Size for the Static RL and Dynamic Load

Weighted Multi Objective Power Quality Index								
Load Type	Bus Number	1	2	3	4	5	Max	Bus Selected
RL Load	Base Case	0.083	1.0206	1.7924	2.303	2.6577	2.6577	Bus-5
	Diesel generator	0.3521	0.5729	0.4221	0.3283	0.2401	0.5729	Bus-2
	Solar PV	0.1532	0.5643	0.5321	0.3587	0.7699	0.7699	Bus-5
Induction Motor	Base Case	0.0921	1.4872	2.4568	0.3433	4.2364	4.2364	Bus-5
	Diesel generator	0.1186	0.8835	0.9621	0.9219	0.7234	0.9621	Bus 3
	Solar PV	0.2358	0.6846	0.5372	0.2643	0.5238	0.6846	Bus-2

Table 3: Results of Case 1 and Case 2 for the selection of Sensitive Bus using WMOPQI

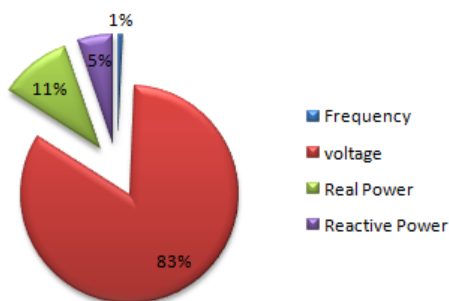

Figure 5:  
Deviation Index for Diesel Generator with Induction Motor load

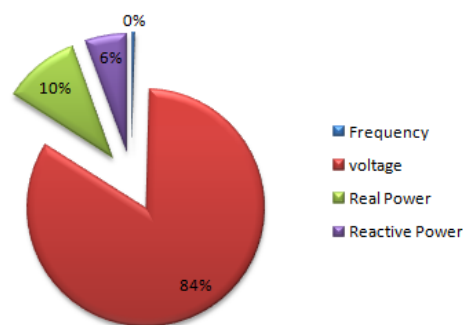

Figure 6:  
Deviation Index for Solar PV Generator with RL load

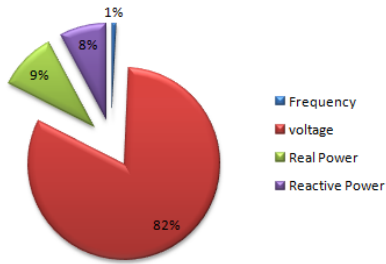

Figure 7:  
Deviation Index for Solar PV generator with  
Induction Motor load

in Case 1 and Case 2. The Rotating DG provides Real and reactive power support hence in Fig. 4 real Power flow deviation is 21% for RL load whereas in Induction Motor Load it is 11%. This is due to the Induction motor load working in 0.85 Power factor. The voltage deviation in the induction motor load case got increased by 10% due to the LLLG fault to compensate for the real power requirement. The difference between reactive power deviation in RL load and Induction Motor load is 0.9%. In the case of B the Voltage deviation, real power Deviation is almost the same for RL load and induction motor load. The Difference in Reactive Power Deviation is less for RL load and Induction motor load due to Grid support. In the absence of Grid support, Reactive power Deviation is high. From Table 3, The Diesel Generator is integrated into the distribution system under the base case the maximum value obtained is 2.655 and the minimum value is 0.083. from [11], [5] and [2] the voltage profile is considered for the detection of a weak node. In the WMOPQI technique, the Maximum value 2.655 at bus 5 is considered as the most sensitive bus and a minimum value of 0.083 at bus 1 is considered as a less sensitive bus that is connected near to Grid. Similarly, the diesel Generator and Solar PV generator connected to the Distributed system is analyzed. From Table 3 it is clear that bus sensitivity depends on the type of DG technology integrated into the distribution system. Lastly, Table 2 presents the data of Distribution Generation, Location and Size for the Static RL and Dynamic Load .

## 6 Conclusion

In Summary, This paper addresses the impact of integrating the static and rotating DG to the distribution system with Grid support and From the reference [5] a VSI [voltage stability Index] method is used to find the location for the integration of DVR which is voltage based analysis hence a

novel approach to finding the sensitive bus with not only voltage but also frequency, real and Reactive power flow is introduced. therefore this method to identify the sensitive bus is known as Weighted multi-objective Power quality Index[WMOPQI]. Since WMOPQI comprises of all the power quality indices, It provides a robust solution to find a sensitive bus for the connection of D-Facts devices. [7] The major disadvantage of weighted multi-objective function is a preference and predicting the coefficient weight value. In this paper by creating various faults in the distribution system, the Maximum permissible deviation value in percentage is obtained. Table 3 shows the result of WMOPQI which shows that the sensitive bus identified changes with respect to the type of DG integrated into the system with Different loads.

## Acknowledgements:

- The authors would like to thank Dr. Archana, HOD NIE Institute of Engineering Mysore for the facility provided in the Department of Electrical and Electronics Engineering.
- We would like to thank Dr. T. Ananthapadmanabha, retd Professor, NIE, Mysuru for the encouraging words that have been extended were a great boost for the completion of this work
- We sincere thank the Doctoral Committee member .Dr. Likith M. V, Associate Professor in Department of EEE, GSSSIETW, Mysuru for continuous guidance
- We would like to thank Mr. Sandeep Kumar K J, Assistant Professor in Department of EEE, NIE Insitute of Engineeering, Mysuru to spend his valuable time encouraging us to do the valuable work

## Conflicts of Interest

The author(s) declare no potential conflicts of interest concerning the research, authorship, or publication of this article.

## References:

- [1] Manjunatha.A, Prathibha.E “Real Time Power Quality Analysis of a Solar Rooftop PV System” International Journal of Electronics Engineering Research. ISSN 0975-6450 Volume 9, Number 7 (2017) pp. 1033-1043.



- [2] B. Wu, Power Conversion and Control of Wind Energy Systems, August 2011, WileyIEEE Press, ISBN: 978-0-470-59365-3.
- [3] Pankaj Gakhar<sup>1</sup>, Tanuj Manglani<sup>2</sup>, Devendra Kumar Doda “Advancement & Role of DG Technology in Distribution System” International Journal of Recent Research and Review, Vol.VI, June 2013 ISSN 2277 – 8322.
- [4] Data Mining for Detection of Sensitive Buses and Influential Buses in a Power System Subjected to Disturbances S. K. Tso, Senior Member, IEEE, J. K. Lin, H. K. Ho, C. M. Mak, K. M. Yung, and Y. K. Ho. IEEE TRANSACTIONS ON POWER SYSTEMS, VOL. 19, NO. 1, FEBRUARY 2004.
- [5] Ram Prakash & B.C. Sujatha “Optimal Placement and Sizing of DG for Power Loss Minimization and VSI Improvement using Bat Algorithm” Department of Electrical Engineering UVCE, Bangalore University Bengaluru.
- [6] R Timothy Marler. Jasbir S. Arora 2010 “The weighted sum method for multi-objective optimization: new insight Struct Multidisc Optim 41:853–862.
- [7] Zhou Hui and Yang Honggeng 2011 “Application of Weighted Principal Component Analysis in Comprehensive Evaluation for Power Quality” IEEE 978-1-4244-9690-7/11: p 369 372.
- [8] Wei Chen and Xiaohong Hao 2011 “Optimal Combination Weights Method Considering Both Subjective and Objective Weight Information in Power Quality Evaluation” Advanced Electrical and Electronics Engineering, LNEE 87, Springer-Verlag Berlin Heidelberg: pp. 97 105.
- [9] Theerachet Soorapanth 2011 “Weighted Deviation Sum Perspective in MultiObjective Geometric Programming “National Electronics and Computer Technology Center, Thailand, IEEE transaction 978-1-61284-857-0/11.
- [10] NAIK R. L, JANGAMSHETTI & SURESH.H. 2014 “Weighted Total Harmonic Distortion and Power Quality Analysis Of Space Vector Modulated Voltage Source Inverters For WECS” International Journal of Electrical, Electronics and Data Communication, ISSN: 2320-2084, Volume-2, Issue-7, July-2014
- [11] Mohan N, Ananthapadmanabha T and A D Kulkarni “A Weighted Multi-Objective Index-Based Optimal Distributed Generation Planning in Distribution System” SMART GRID Technologies, August 6-8, 2015
- [12] R. P. Payasi<sup>1</sup>, Asheesh K. Singh, Devender Singh, Navneet K. Singh 2015 “Multi-objective optimization of distributed generation with voltage step constraint” International Journal of Engineering, Science and Technology, Vol. 7, No. 3, 2015, pp. 33-41
- [13] Vishwanath G, Lokesh M, A D Kulkarni “The Impact of Location and Size of the Wind Technology on Power Quality in a Distribution System with Different Loads” International Journal of Innovative Technology and Exploring Engineering (IJITEE) ISSN: 2278-3075, Volume-9, Issue-1, October 2019

### **Contribution of individual authors to the creation of a scientific article (ghostwriting policy)**

The author(s) contributed in the present research, at all stages from the formulation of the problem to the final findings and solution.

### **Sources of funding for research presented in a scientific article or scientific article itself**

This research was supported by Visvesvaraya Technological University, Jnana Sangama, Belagavi -590018 for Grant of financial assistance. Also, this research was carried out in the "NIE Research Center", Mysore (affiliated to VTU belagavi).

### **Creative Commons Attribution License 4.0 (Attribution 4.0 International, CC BY 4.0)**

This article is published under the terms of the Creative Commons Attribution License 4.0 [https://creativecommons.org/licenses/by/4.0/deed.en\\_US](https://creativecommons.org/licenses/by/4.0/deed.en_US)