

# Thermal modelling and power consumption estimation of a multi floor small scale building using SPICE simulator.

Ph. DONDON<sup>1</sup>, C.A BULUCEA<sup>2</sup>

<sup>1</sup>Université de Bordeaux, IPB, UMR 5218, Av Dr A. Schweitzer 33405 Talence, FRANCE.

<sup>2</sup>Faculty of electrical engineering, University of Craiova, ROMANIA

*Abstract:* This study is a part of a concrete sustainable development project introduced at university. A small scale genuine materials house (1/20 scale) with its green energy sources and electronic circuits management have been designed for educational and research purpose [1]. Thanks to a modular design and optional accessories, many thermal and electronic measurements and modelling are possible, like in a real house. A SPICE equivalent thermal behaviour modelling is proposed. Once validated, a case of study for a three floor small scale building is presented. Power consumption and insulation efficiency are analyzed. Main tendencies are checked after comparison with a real multi floor building. Results are finally discussed.

*Key words:* thermal modelling, SPICE modelling, Education to Sustainable development, Infrared imaging,

Received: April 17, 2021. Revised: December 29, 2021. Accepted: January 14, 2022. Published: February 9, 2022.

## 1. Introduction

This global project was carried out through national collaboration with “the House of the Nature and the Environment” (MNE) of Bordeaux, national french organism ADEME (Agency of the Environment and the Control of Energy) France, the ENSEIRB-MATMECA (33400 Talence), the colleges Chambéry (33140 Villenave d'Ornon) and Henri Buisson (33400 Talence) (professors and pupils) for the realization of the small scale house.

Pure thermal modelling is obviously a complex domain which requires high knowledge level and specialists [2], [3], [4]. Commercial software [5], [6] are still used by architects and houses builders.

However, the aim of this study is not to make competition with existing well tried software but more surely to obtain a quite simple thermal behaviour modelling of a small scale building, in order to have an easy understanding compatible with our electronic culture. Modelling must be just fine to easily understand main tendencies, the effect of double internal or external insulation, thermal inertia and to run simple day/night scenario in order to predict heating power consumption for educational purpose.

## 2. Thermal modelling extraction flowchart

### 2.1 One floor small scale house design

For easy use and pedagogical reasons, we firstly built a small scale one floor house (cf. figure 1). This building with genuine materials required more than 1500 hours of work including pupils, students and teachers work [1].

The dimensions of the 1/20 scale house model are 50cm x 50cm (external walls included). Useful internal surface is 45cm x 45cm. It consists of 3 independent parts encasable like a “turned over shoes box”. First part is external walls. They are made of Autoclaved Aerated Concrete (AAC) 2.5cm thickness (part 1) coated and painted. There are one door (PVC) and 4 windows (three single glazed, and one double glazed).

The floor is made of a wood plate (22mm thickness) covered by a 3mm polyurethane scaled insulation film. The second part is a removable pitched roof. It is made of pine tree wood parallel roof truss, covered with terra cotta tiles. Attic may be filled with mineral wool insulation. A roof solar panel is integrated on one side of the roof.

The third part has an interchangeable interior insulation double wall and ceiling. It is encasable from the top, inside the external walls. Three “boxes” with three types of insulators have been designed to be able to make practical thermal performances comparison. Each “insulation box” consists of 3 parts:

Part 1: 3mm thickness Forex frame (walls and ceiling), for mechanical rigidity

Part 2: 5mm polystyrene layer for the ceiling (ceiling internal surface: 41cmx41cm)

Part 3: wall insulation layers. Depending of the “box”, walls are insulated as follow:

- Mineral wool (6mm thickness + thin aluminium sheet to press lightly the wool) (insulator n° 1).
- Polystyrene insulator 5mm, (insulator n°2).
- Thin cork layer 3mm (insulator n°3).

Figure 1 shows a picture of the finished scale modular small scale house model.



Figure 1: Finished small scale house.

The “underground” is used for electrical wiring and circuit installation (heating circuits, lightning control, “green” power sources management system, and future home automation system).

The scaled installed power heating source is a 20W halogen spotlight. It corresponds to a classical 6KW installation for a 80/90 m<sup>2</sup> “average” house in southwest France. It is controlled by an “on/off” signal with an adjustable duty cycle to regulate the inside temperature.

## 2.2 Practical characterisation

Practical experiments on this one floor small house have been previously described in [7] and [8]. From these measurements, we extracted surface temperature and inside temperature under various scenarios in order to start a modelling.

## 2.3 One floor SPICE Modelling

### 2.3.1 Thermal and electrical equivalence

The equivalence and analogies between electrical and thermal quantities are given in table 1.

Thermal quantities			Electrical quantities		
T	Temperature	°K	U	Voltage	V
J	Heat flux	W/m <sup>2</sup>	J	Current density	A/m <sup>2</sup>
P	Heat	W	I	Current	A
Q	Heat quantity	J=W.s	Q	Charge	C=A.s
$\lambda_{th}$	Conductivity	W/(°K.m)	$\sigma$	Conductivity	1/( $\Omega.m$ )
R <sub>th</sub>	Resistance	°K/W	R	Resistance	$\Omega$
C <sub>th</sub>	Capacitance	W;s/°K	C	Capacitance	F

Table 1: Thermal and electrical equivalence

Thermal to electrical equivalence summarized in table 1, are detailed in [9]. Thus, each “thermal way” can be classically modelled [10], by R, C electronic network circuits, where R represents the thermal resistance and C the thermal inertia of each material layer used in the building. The heating source (in W) is represented by a current generator and temperature by voltage node values in a SPICE simulation.

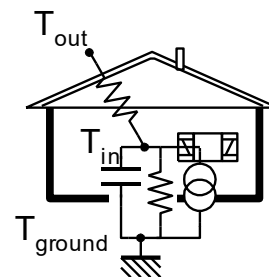

Figure 2: Intuitive ultra simple modelling

### 2.3.2 Thermal paths identification

The most simple and rough localized time constant equivalent circuit is given in figure 2.

Between this ultra simple modelling and a fine modelling, we suggest here a medium complex modelling enough detailed to understand the major thermal aspects.

Six main and parallel “thermal ways” are identified (cf. figure 3):

- Four through the vertical walls (single glazed windows, double glazed window, door and insulated wall)
- One through the ceiling,
- One through the basement.

A typical thermal “equivalent” electrical schematic for one path is given in figure 4. R<sub>int</sub> and R<sub>ext</sub> represent the “in” and “out” thermal resistance of superficial exchange. Each layer is represented by a R, C network. R (°C/W), C (W.s/°C) values are estimated from materials thermal characteristics given in (Louvain catholic university (Belgium) database [11]) and from the geometrical characteristics of the each small house parts (surface and thickness).

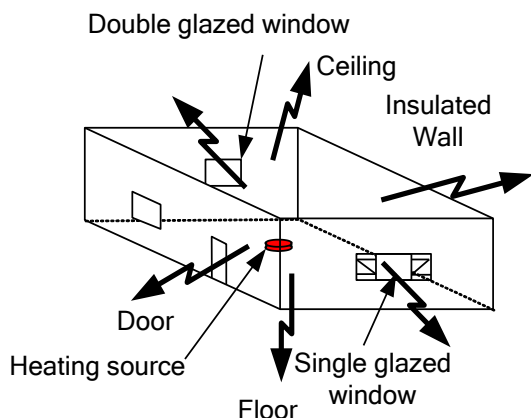

Figure 3: Identified thermal paths

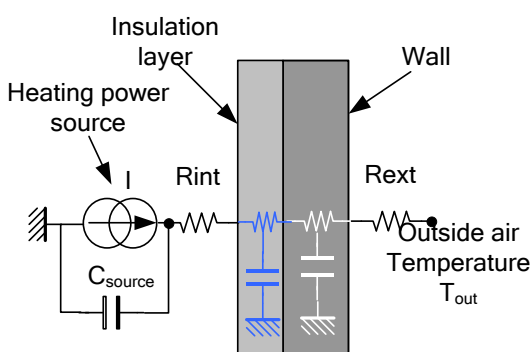

Figure 4: Typical equivalent path

The scaled heating source is sized to 20W. As indicated before, it corresponds to a classical installed power of 6kW for an 80/90m<sup>2</sup> “average” house in South France. This source is thus modelled by a 20A Spice voltage controlled DC current source, with a parallel capacitor representing its thermal inertia.

### 2.3.3 House temperature regulation modelling

Once the thermal equivalent modelling of the small house defined, the electronic temperature control system was included in the schematic.

The principle of temperature control loop is given in figure 5. It is an “on/off” regulation like the common classical electrical heaters in true houses. Thus average heating power is given by the duty cycle  $T_{on}/(T_{on}+T_{off})$ .  $T_s$  is the inside ‘comfort’ temperature set point, tuneable by the user, like in a real house. The measured “in” temperature  $T_{in}$  is compared to  $T_s$  and heating source is turned “on” or “off”, according to a chosen hysteresis of 1°C around the  $T_s$  value.

The heating source and switch are simulated by a Voltage Current Controlled Source (VCCS Spice component) while comparator stage is a simple

LM311 circuit with 2 resistances to make a temperature hysteresis.

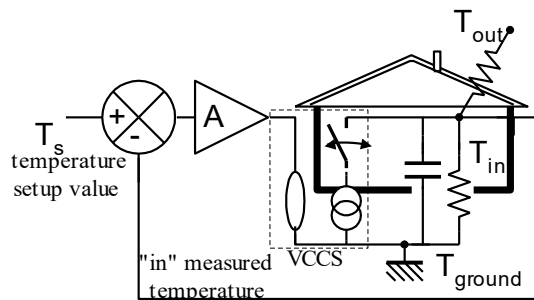

Figure 5: Temperature control principle

Control circuit is merged with the previous schematic presented in §4.4, to built a complete equivalent circuit (cf. figure 6).

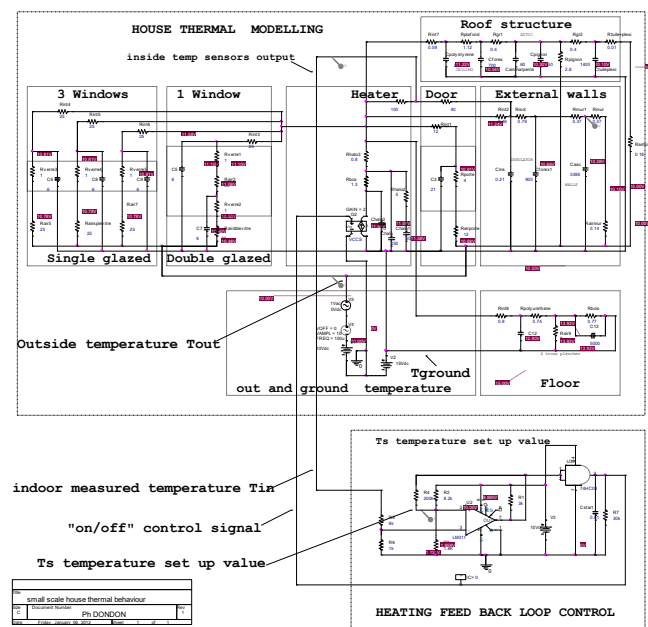

Figure 6: Temperature feed back loop control

### 2.4 Simulation and modelling validation

A complete set of simulations has been done under various conditions for  $T_s$ ,  $T_{out}$  and  $T_{ground}$ , without or with various internal insulations. We give hereafter only the most significant simulation results.

#### 2.4.1 Simplified night and day scenario

Figure 7 shows the regulation efficiency under the following scenario:

- Temperature  $T_s$  set up value: 18°C
- Ground temperature  $T_{ground}$ : 15°C
- House double wall insulation: insulator n<sup>o</sup>2.

- Outside Air  $T_{out}$ : high day/night amplitude temperature from 20°C to 0°C with a sine waveform representing a scaled day night cycle.

Vertical scale: 0 to 20V (i.e. 0°C to 20°C)  
 Horizontal scale: time 0 to 20.000s  
 Upper trace (green): regulated  $T_{in}$  temperature  
 Middle trace (blue): outside air temperature simulated variation  
 Lower trace (red): heating “on/off” control signal

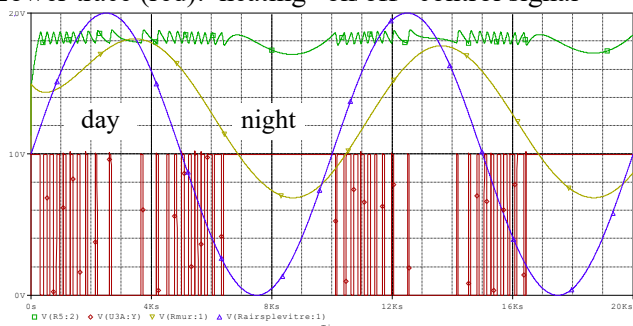

Figure 7: High amplitude outside air temperature variation

$T_{in}$  (green curve) is no more well regulated at the end of the night. It decreases as shown on figure 7: The feed-back control system do not work anymore correctly at the end of the night because the installed heating power (20W) is no more sufficient despite a permanent ‘on’ state (red curve) during low outside temperature.

### 2.4.2 Insulation efficiency and power consumption comparison

Energy efficiency of the house is obviously related to insulation efficiency.

A comparison can be easily done by placing or removing R, C components corresponding to insulator layers on SPICE small scale house modelling given in §4.4.

For these simulations, we set up the following conditions:

- Temperature  $T_s$  set up value: 18°C
- Initial outside Air  $T_{out}$  : 12°C
- Ground temperature  $T_{ground}$ : 15°C

Average power consumption in each situation is then evaluated considering the duty cycle of the “on/off” control signal in steady state situation. Initial condition is  $T_{in} = T_{out}$  while house is not heated. At  $T=0$ , the heating source in turned “on”. And the settling time correspond to the necessary time to reach the  $T_s$  set up value.

Upper trace: regulated  $T_{in}$  temperature  
 Middle trace outside air temperature (12°C)  
 Lower trace: heating “on/off” control signal

Horizontal scale total time: 20.000s  
 Vertical scale: 0V to 20V (i.e. 0 to 20°C)

Figure 8 shows the house behaviour when internal wall and ceiling insulation is totally removed.

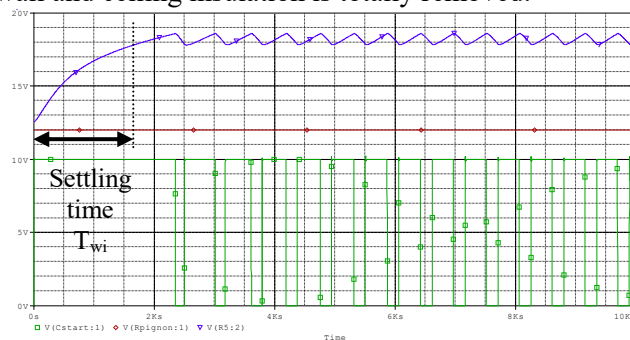

Figure 8: Transient and steady state without internal insulation

In this first case, the duty cycle is 0.72 in steady state situation: Thus, an average heating power of  $20W \cdot 0.75 = 14.5 W$  is required.

The required settling time  $T_{wi}$  to reach steady state (i.e.  $\Delta T=5.3^\circ C$  rise from 12.7°C to 18°C) is around 1620s (i.e 27 minutes).

Figure 9 shows the house behaviour when equipped with internal wall and ceiling insulation  $n^{\circ}2$  (i.e. polystyrene layer).

In this second case, the duty cycle becomes 0.481 in steady state situation. Thus, it requires an average heating power of  $20W \cdot 0.481 \approx 9.62 W$ .

And the required settling time  $T_i$  to reach the same steady state (i.e. from 12.7°C to 18°C) is roughly 3 times less than in the first case for the same temperature elevation (510s against 1620s)

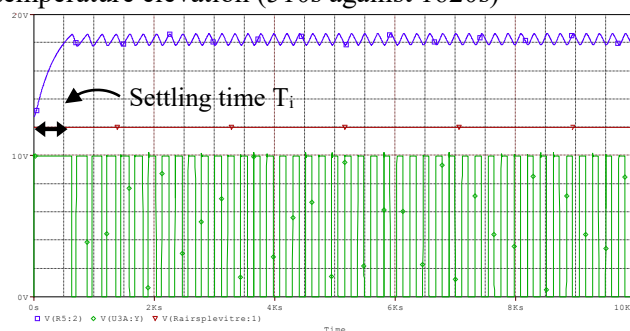

Figure 9: Transient and steady state response with internal insulation  $n^{\circ}2$  (polystyrene)

Thus, between a “non insulated” house and a full well insulated house, a heating power significant reduction of around 30% to 40% can be predicted by SPICE simulation.

Experimental results using this modelling and comparison with simulation were previously published in [12] and [13].

### 3. Extrapolation to a three floors small scale house

Once validated, previous modelling can be extended to a collective housing to analyse the global power consumption of a whole building and also the individual consumption of each flat.

For this purpose we set up the following conditions:  
 The collective housing consists of three identical floors (previously described) with their independent heating sources.

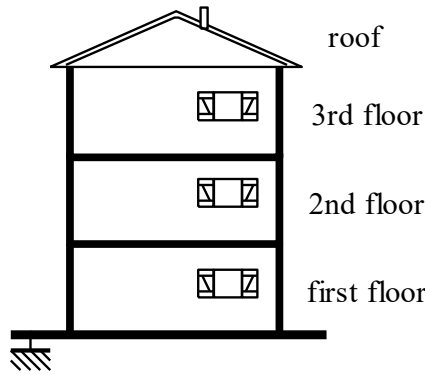

Figure 10: three floor small scale house

#### 3.1 Equivalent SPICE Modelling

For this purpose, previous “one floor small scale house modelling” with its temperature regulation circuit given in figure 6, is slightly adapted. Indeed, this modelling can be seen as a linear black box with four main input/output:

- $T_{out}$  (outside air temperature),
- $T_{ground}$ , ground temperature,
- Ground connexion
- Ceiling connexion.

Thus, it has been transformed in a SPICE sub-circuit. Three identical sub-circuits have been included on a hierarchical design sheet as indicated in figure 21. Roof structure has been connected to the last level. Ceiling of one level is linked to the floor of the above level. External voltage source allow to set up outside air and ground temperature.

Several transient simulations have been performed under the following conditions:

- Temperature  $T_s$  set up value on each floor: 18°C

- Outside Air  $T_{out}$ : 7°C
- Ground temperature  $T_{ground}$ : 15°C
- Power heating source installed in each flat  $P=20W$

Tables 2 to 5 give simulations results for various situations, when the steady state is reached (i.e. temperature regulation locked).

In these tables, period T (first column), “on” state duration (middle column) and duty cycle (right column) of the “on/off” heating control signal of each floor is reported.

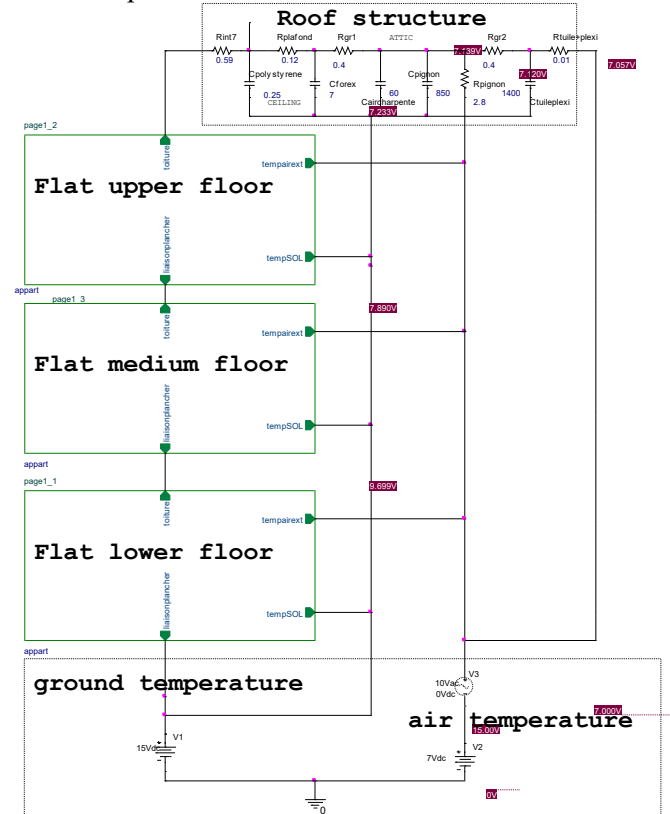

Figure 11: Three floors house modelling

As the installed power P values is the same for each floor, the comparison of respective duty cycle values gives quantitative data on insulation impact and power consumption improvement.

#### 3.2 Simulation of the impact of roof insulation

Tables 2 and 3 compare the impact of roof insulation on power consumption of each flat.

The required heating power to maintain the desired  $T_{in}$  temperature is an image of the duty cycle  $T_{on}/T$  with  $T = (T_{on} + T_{off})$  as described on figure 7 to 9. The duty cycle reported in table 2 to 5 is obtained by running several simulations, and measured with cursors on spice curves similar to figure 7 to 9.

	T(s)	Ton(s)	dutycyle
Upper floor	979	802	0.82
Medium floor	454	193	0.42
Lower floor	496	254	0.51

Table 2: Without roof insulation

with isolation	T(s)	Ton(s)	dutycyle
Upper flat	527	345	0.65
Medium flat	495	202	0.40
Lower flat	481	244	0.50

Table 3: With roof insulation

Analysis of these data leads to the following conclusions:

Insulation of the roof structure generates obviously a global power consumption reduction. Improvement depends logically on the floor:

- the gain on upper floor is around 20% (1-0.65/0.82)
- the gain on medium floor is around 5% (1-0.4/0.42)
- the gain on lower floor is around 2% (1-0.5/0.51)

The lower power consumption is located in the intermediate floor and confirms an intuitive understanding. Power consumption of the upper floor can reach 40% more than an intermediate floor.

### 3.3 Simulation of the impact of walls insulation

Tables 4 and 5 compare the impact of wall insulation with internal insulation n<sup>2</sup> (polystyrene) on power consumption of each flat.

Without insulation	T(s)	Ton(s)	dutycyle
Upper flat	3810	3580	0.93
Medium flat	1018	640	0.62
Lower flat	1360	1054	0.77

Table 4: Without double wall insulation

with insulation	T(s)	Ton(s)	dutycyle
Upper flat	527	345	0.65
Medium flat	495	202	0.40
Lower flat	481	244	0.50

Table 5: With double wall insulation

Analysis of these data leads to the following conclusions:

Insulation of the external walls obviously generates a global power consumption reduction. Improvement depends logically on the floor:

- the gain on upper floor is around 30% (1-0.65/0.93)
- the gain on medium floor is around 35% (1-0.4/0.62)
- the gain on lower floor is around 35% (1-0.5/0.77)

Because of relative losses through the roof mainly supported by the last floor, relative impact of wall insulation on upper floor is less than the others.

## 4. Result analysis

Confirmation of intuitive understanding of the main tendencies in house power consumption and insulation impact can be well demonstrated by SPICE. Simulation time is very short (few seconds) compared to simulation by finite element commercial software such as ANSYS/SILVACO which could take a few hours depending on mesh size and mesh number.

The main advantages of our SPICE modelling are given hereafter:

- Transposing thermal phenomenon into electronic “world” allows an easy understanding of thermal problems for non thermal specialists,
- The “mixed” thermal and electronic simulation for temperature makes the feed back loop design and stability checking easy for electronic specialists. The impact of installed heating power on regulation quality can be precisely visualized,
- Displaying node voltages allows a direct access to surface temperature (walls, windows),
- Possible use for educational purpose and initiation of electronic students during a standard 4 hours practical lesson.

The main disadvantages are given below:

- The modelling is a simple 1D linear modelling. It does not take into account surface and volume effect,
- This is not a parametric modelling: Changing size of the house or material properties requires a recalculation of each R, C cells,
- Natural air movement or forced air ventilation are not simulated,
- No occupation rate scenario
- No global vision over a full year,
- Do not take into account solar fluxes.

## 5. Small Scale to full scale extrapolation

Results obtained on the Spice small scale modelling can obviously not be extended to a true building by a simple homothetic transformation: Indeed, let “f” to be the scale factor, here (x20). At first order, components values in SPICE modelling should be modified as follow:

Thermal resistances should be multiplied by 1/f. Thermal capacitance should be multiplied by f<sup>3</sup>. And R<sub>int</sub>, R<sub>ext</sub> coefficients should be multiplied by 1/f<sup>2</sup>. Moreover, some thermal phenomenons are not linear direct and diffused solar radiation, convection, are not taken into account in Spice simulations.

## 6. Checking main tendencies

Even if Spice simulations on small scale house can not be transposed directly to a true building, we can check the main tendencies: Figure 12 and 13 show infrared images of two old buildings initially built at the same period, with same materials, and side by side: the first one does not have any insulation and the second was

fully renovated with polystyrene external insulation. Effect of insulation is well observed: insulated outside surface of the renovated building is 1.2°C colder than the outside no-insulated surface, for an outside air temperature of -5°C. Moreover, measurements were performed in an apartment located at the last floor of the renovated building. Global insulation has divided by more than 2 the annual heating power consumption for the same comfort temperature (18°C°).

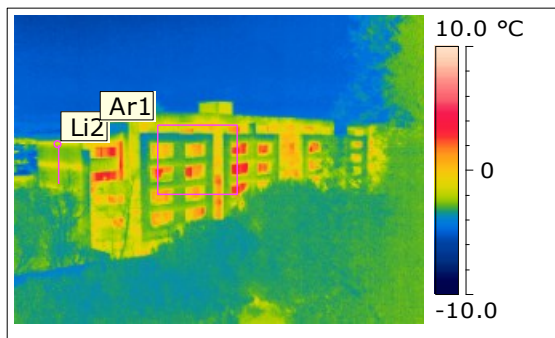

Figure 12: non insulated building

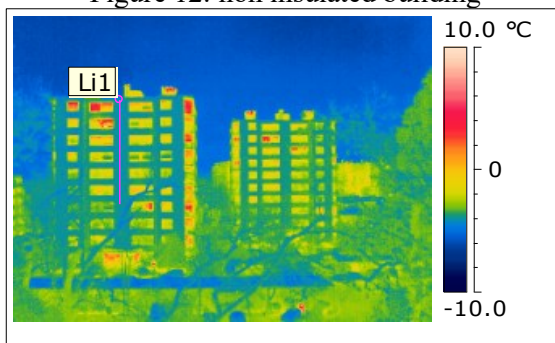

Figure 13: Fully well insulated building

Main tendencies obtained in Spice simulation are thus confirmed with true experiments.

## 7. Future work

Some improvements will be included on our SPice modelling such as an “air-conditioning” fac-simile system, and direct solar flux equivalent input to make our modelling more realistic. Also a comparison with CODYBA software [14] uses and results especially designed for building thermal analysis will be done [ ]. Finally, this work will be now adapted and converted for creating practical lesson included in a sustainable development thematic.

## 8. Conclusion

Three years were necessary to design a fully functional realistic small scale house, built in genuine materials. It was completed successfully within the framework of an innovative sustainable development project. An equivalent SPICE thermal modelling was built and extended to a three floor house. Relative main tendencies were demonstrated like in a true house. Finally, validity of modelling was checked by some experimental thermal measurements. This work will be now transferred for educational purpose.

## Tghgt gpegu

- [1] Ph. Dondon- P. Cassagne- M. Feugas- C.A. Bulucea-D .Rosca- V. Dondon- R.Charlet de Sauvage “Concrete experience of collaboration between secondary school and university in a sustainable development project: design and realisation of a realistic small scale house to study electronic and thermal aspect of energy management in an electronic engineering school.” WSEAS trans. on Environment and Development Vol.7, 2012
- [2] M. Chereches, C.Popovici, N.-C. Chereches “Experimental and Numerical Approach of the Thermal Conductivity of Building Façade Materials” WSEAS Trans. on Heat and Mass Transfer Vol.5, 2010
- [3] D. Popescu, C. Ciufudean “Automatic Control System for Heating Systems in Buildings Based on Measuring the Heat Exchange through Outer Surface” 8th WSEAS Int. Conf. on Simulation, Modelling and Optimization, Sep 23-25, 2008 Santander, Spain
- [4] G. Manioglu, V. De Meulenaer, J.Wouters, H. Jens, “Thermal Performance of a Passive House: Measurements and Simulation”11th Int. Conf. Thermal Performance of the Exterior Envelopes of Whole Buildings, Dec 5-9, 2010 Clearwater Beach, Florida
- [5] <http://www.izuba.fr/logiciel/pleiadescomfie>
- [6] <http://www.designbuilder.co.uk/>
- [7] Ph. Dondon, R. Charlet de Sauvage, C.A Bulucea “Enhancing knowledge on energy saving and insulation efficiency in buildings by analysing thermal transient behaviour of a realistic small scale house” NAUN Int. Conf. on Energy Systems, Environment, Entrepreneurship and Innovation Feb 13-15 2016 Barcelona, Spain
- [8] Ph. Dondon- C.A. Bulucea- R. Charlet de Sauvage “Sustainable development education in an electronic engineer school: experimental study of thermal losses in a realistic small scale house by infrared thermal imaging” WSEAS Trans. on Advances in Engineering Education Vol. 10, p.113 July 2013
- [9] M. Correvon “cours d’électronique de puissance chapitre 9 : modélisation thermique des composants” Institut d’automatisation industrielle HES SO, Suisse
- [10] W. HABRA “Développement de Modèles Thermiques Compacts en Vue de la Modélisation Electrothermique des Composants de Puissance ” Ph.D, june 28 2007, Laboratoire d’Analyse et d’Architecture des Systèmes LAAS-CNRS l’Université P. Sabatier, Toulouse France
- [11] [http://www.energieplus-lesite.be/energieplus/page\\_10252.htm](http://www.energieplus-lesite.be/energieplus/page_10252.htm)
- [12] Ph. Dondon, R. Charlet de Sauvage, C.A Bulucea “Thermal transient behaviour and insulation efficiency analysis of a realistic small scale house” WSEAS Trans on Environment and Development pp. 95-107 vol 12, Mars 2016, ISSN / E-ISSN: 1790-5079 / 2224-3496
- [13] Ph. Dondon- C.A Bulucea- M. Feuga " Power consumption modelling of a realistic small scale house; a sustainable development project in electronic engineer school." WSEAS Trans on Environment and Development pp419-429 Vol 15 2019 E-ISSN: 2224-3496
- [14] J.Noël, J.-J Roux « Présentation du langage de commande de CoDyBa. Application au cas d'une passerelle TRNSYS-CODYBA », IVe Journées TRNSYS, 2001.
- [15] R.Bruno,P. Bevilacqua, V. Ferraro, N.Arcuri “Reflective thermal insulation in non-ventilated air-gaps: experimental and theoretical evaluations on the global heat transfer coefficient” Energy and Buildings Vol 236, 1 April 2021

## Creative Commons Attribution License 4.0 (Attribution 4.0 International, CC BY 4.0)

This article is published under the terms of the Creative Commons Attribution License 4.0  
[https://creativecommons.org/licenses/by/4.0/deed.en\\_US](https://creativecommons.org/licenses/by/4.0/deed.en_US)