

Studies regarding the modeling of a wind turbine with energy storage

GIRDU CONSTANTIN CRISTINEL
School Inspectorate of County Gorj,
Tg.Jiu, Meteor Street, nr.11
ROMANIA

Abstract: This paper presents the modeling in Matlab-Simulink of a stand-alone wind turbine system with energy storage dedicated for small power wind turbines of 3kW with a variable speed permanent magnet synchronous generator (PMSG), diode rectifier bridge, buck-boost converter, bidirectional charge controller, transformer, inverter, ac loads and energy storage devices. Are presented the general system configuration, the Simulink block diagram and the main simulated characteristics resulting from the dynamic performances during the wind speed variation.

Key words: wind energy, Matlab-Simulink modeling, wind turbine, energy storage.

1 Introduction

The renewable resources named also “green resources” are theoretically inexhaustible and permit to replace the use of fossil fuels for coming in order to reduce the greenhouse gases effects. Furthermore, they are present all over the world, free to use, and do not cause pollution. The use of renewable energies will continue to grow, and such plants will become cheaper and more readily accepted by the market. Since, they represent a great alternative to fossil fuels, the European countries start policies to promote renewable energy technologies and to supply electricity using a mix of traditional fossil fuels and “green resources”.

Among these resources, wind is the cheapest on a large scale to transform into electrical energy.

That is why much attention is paid nowadays to wind energy conversion systems.

2 Wind turbine system configuration

The wind turbine studied is a small power one with a rated power of 3kW and the blade diameter of 4m.

It contains a permanent magnet synchronous generator (PMSG), buck-boost converter, transformer, inverter, ac load, and lead acid batteries (LAB) and supplies single-phase consumers, at 230V and 50Hz, as shown in Fig.1.

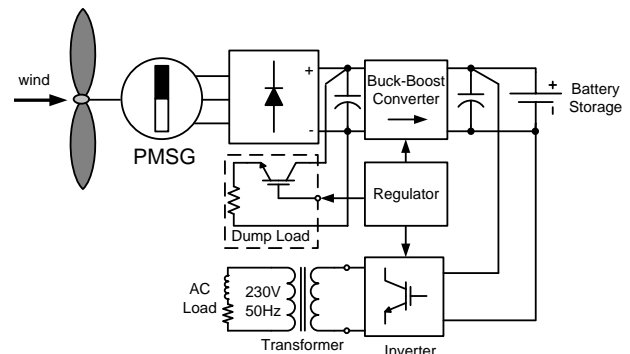

Fig.1 Wind turbine system configuration

This topology is built in order to obtain a maximum efficiency for the system. The regulator measures the main system’s parameters – wind speed, battery voltage and current, PMSG’s rotor speed – and controls the buck-boost duty-cycle, commands the dump load and gives the inverter’s modulation index.

The main advantage of variable speed operation is that more energy can be generated for a specific wind speed regime. Although the electrical efficiency decreases, due to the losses in the power electronics that are essential for variable speed operation. There is also a gain in aerodynamic efficiency due to variable speed operation. The aerodynamic efficiency gain exceeds the electrical efficiency loss, overall resulting in a higher energy yield. There is also less mechanical stress, and noise problems are reduced as well, because the turbine runs at low speed when there is little wind.

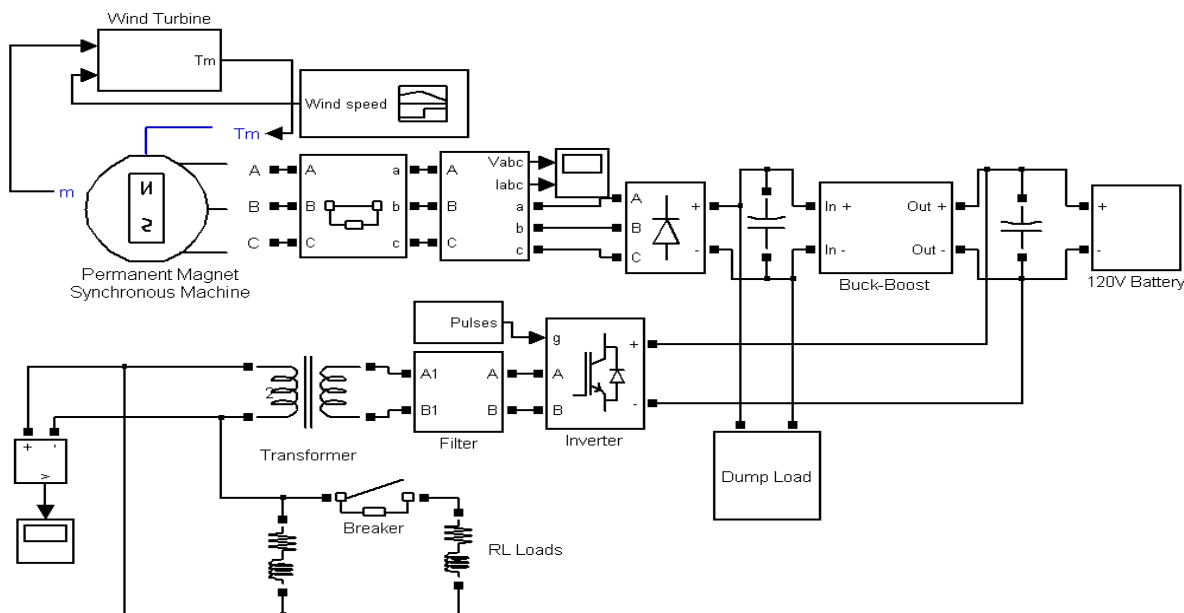

Fig. 2 Simulink diagram of the wind system

3 Matlab – Simulink system modeling

The proposed system has been modeled and simulated using the Matlab - Simulink software and is depicted in Fig.2. The wind variation for a typical site is usually described using the so-called Weibull distribution. The statistical distribution of wind speeds varies from place to place around the globe, depending upon local climate conditions, the landscape, and its surface. The wind speed variation is best described by the Weibull probability distribution function [6].

To obtain the Simulink whole wind system diagram, has been considered the models for the wind turbine, PMSG, buck-boost converter, diode bridge rectifier, inverter and the storage LAB presented in [1,2,3,4,5].

The electrical part of the wind turbine modeled is composed by a 3kW PMSG, diode bridge rectifier, converter, transformer, inverter, ac loads and storage devices. The turbine Simulink model (see Fig. 2) is based on the Maximum Power Point Tracking (MPPT) method used in order to maximize the electric output power extracted from the wind energy conversion [1]. In this case, the tip speed ratio λ in pu of λ_{nom} is obtained by the division of the rotational speed in pu of the base rotational speed and the wind speed in pu of the base wind speed. In this aim we consider the output power of 3kW, the base wind speed of 12 m/s, the maximum power at base wind speed of 0.9 pu ($k_p = 0.9$) and the base rotational speed equal 1 pu). The output is the torque applied to the generator shaft T_m , is based on the nominal generator power and speed.

The mechanical power P_m as a function of generator speed, for different wind speeds and for the blade pitch angle $\beta = 0$ degree, is illustrated in Fig.3.

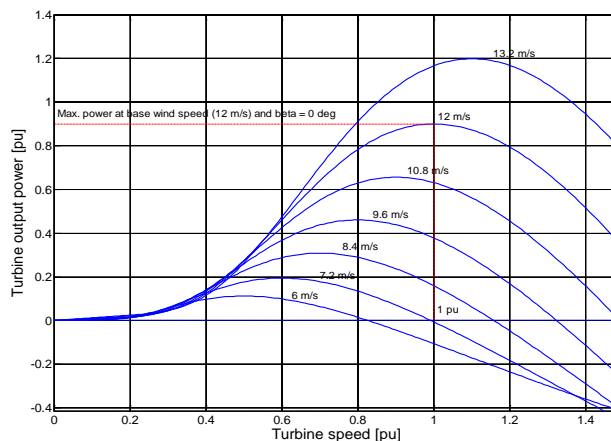

Fig. 3 Wind turbine characteristics at 3 kW

This figure is obtained with the default parameters (nominal mechanical output power = 3kW, base wind speed = 12 m/s, maximum power at base wind speed = 0.9 pu ($k_p = 0.9$) and base rotational speed = 1 pu). The wind turbine power curve permits a maximum power of 3.5kW [8].

For the system modeling, the main library used was Sim-PowerSystem.

The PMSG has a sinusoidal flux distribution, 4 pole pairs, per-phase stator resistance $R=0.458 \Omega$, $L_d = L_q = 0.00334$ H, flux induced by permanent magnets in the stator windings $\Psi = 0.171$ Wb.

The battery bank consists in five 24V batteries series connected.

A $P=1\text{kW}$ and $Q=500\text{var}$ ac load is considered and it's switched on and off in order to analyze the system's dynamic behavior.

4 Dynamic behaviour simulations

Simulations were carried out in the following situations:

- start-up process;
- variable wind speed behavior;
- variable load behavior.

The **start-up process** takes place at a wind speed of 4m/s . The PMSG is considered connected at $t = 1\text{s}$, when the generator operates under steady-state condition. In the Fig. 4 are shown the rotor speed and the electromagnetic torque.

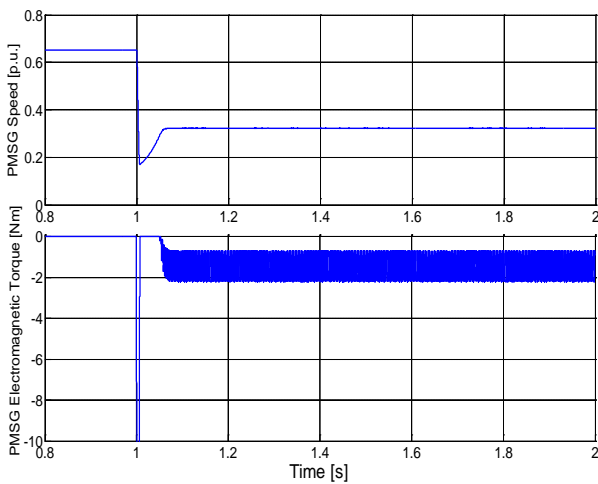

Fig. 4 PMSG rotor speed and electromagnetic torque

The initial disturbance is amplified by the inertia moments of the rotating elements.

In the Fig.5 is depicted the electromagnetic torque variation around its steady-state value.

The electromagnetic torque has an initial sharp step.

The transitory regime lasts about 0.2s and after that, another steady-state regime is established.

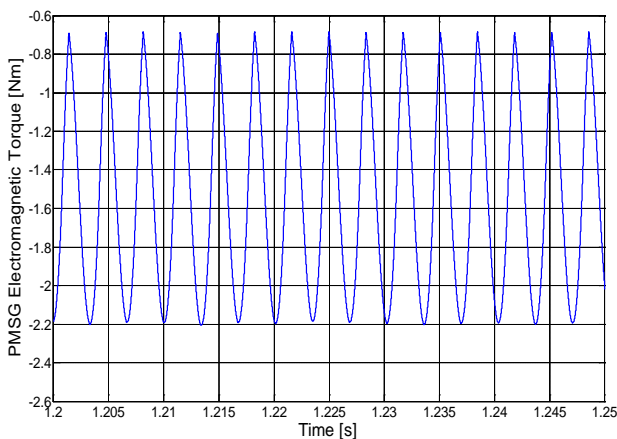

Fig. 5 PMSG electromagnetic torque variation

The dc rectifier bridge voltage link, is about 85V according to the wind speed and is depicted in the Fig.6.

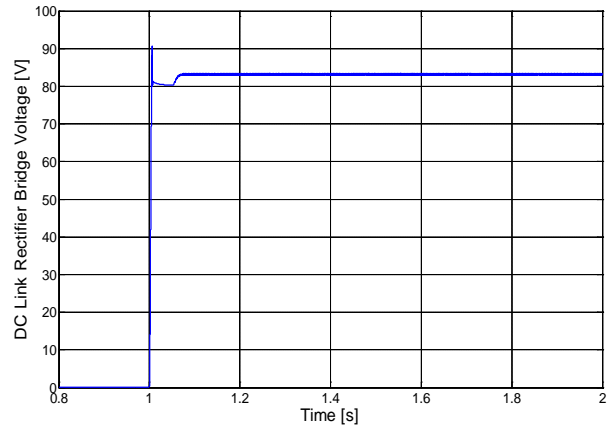

Fig. 6 The dc link rectifier bridge voltage

During the PMSG non-operating moments, the loads are fed by the battery bank.

For the **variable wind speed behaviour**, is considered a wind speed decrease from 10m/s to 7m/s at the moment $t = 1\text{s}$, which affects the system's power balance. In the Fig.7, the rotor speed is shown.

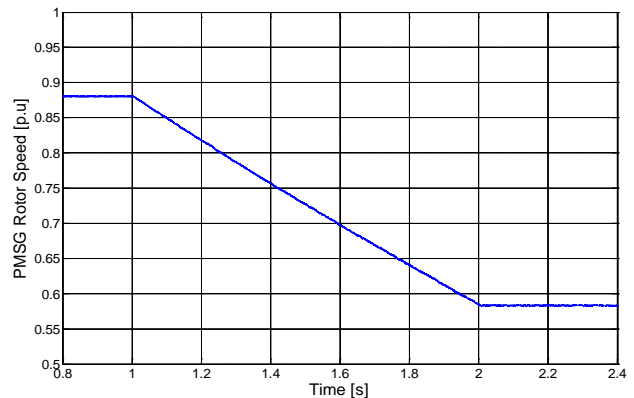

Fig. 7 The PMSG rotor speed

The system is initially in steady-state. The battery voltage is about 135V . The PMSG's operating point depends on the wind speed and on wind characteristics.

This change affects the system power balance.

The PMSG's electromagnetic torque (Fig.8) decreases to about 60% (negative is generating), consequently the generated power decreases also.

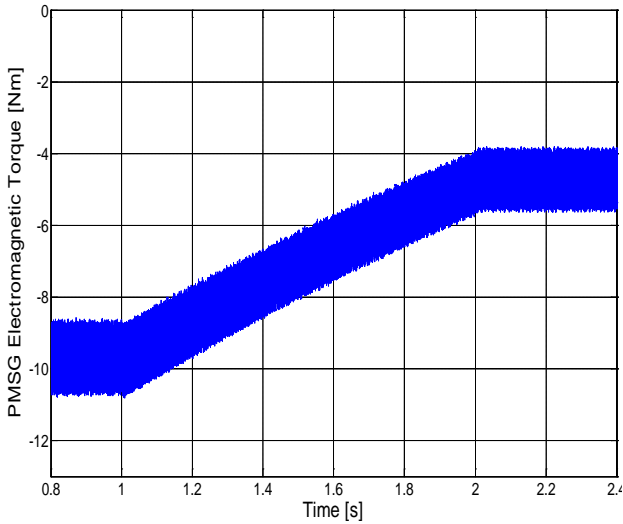

Fig. 8 The PMSG electromagnetic torque

The dc link rectifier bridge voltage, depicted in the Fig.9, decreases from 205V to about 145V.

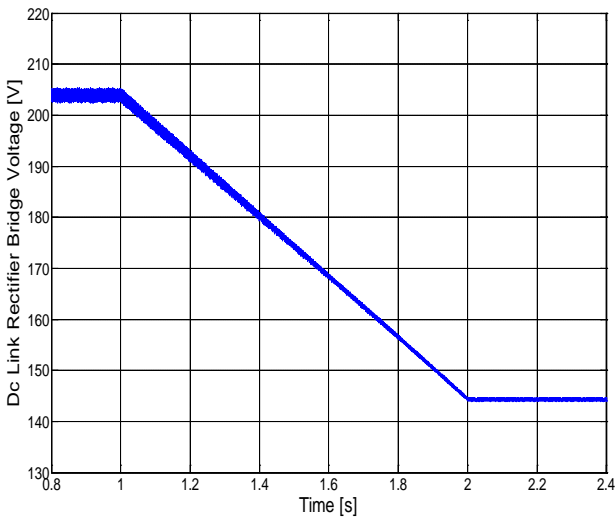

Fig. 9 The *dc* link rectifier bridge voltage

During this process, the average battery current falls from 6.5A to about -1.5A, as shown in the Fig.10. In order to provide a loads permanent supply, the battery will pass from charging to discharging mode.

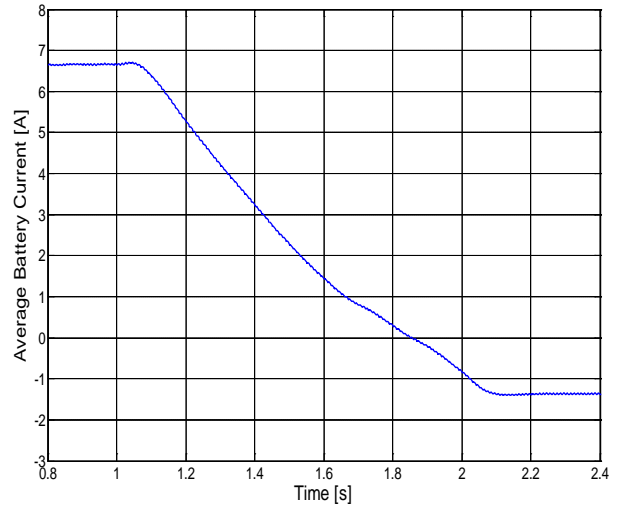

Fig.10 The battery average current

At *variable load behavior*, the wind velocity is assumed constant at 10 m/s, the initial load has $P = 500W$ and $Q = 100VAR$ and the PMSG is operating in steady state conditions.

At the moment $t = 2s$ an initial load is suddenly connected.

Then, after $t = 3s$, this load is disconnected. In this case, in Fig.11, the ac voltage's shape is depicted.

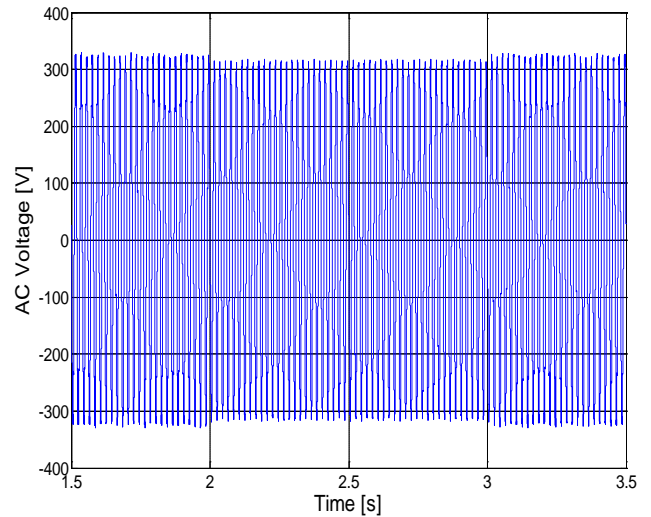

Fig. 11 The *ac* link voltage

During the transitory time, the voltage shape presents small sags. Because the mechanical power delivered to the PMSG is constant, the power balance is maintained by varying the battery's charging current, as shown in Fig.12.

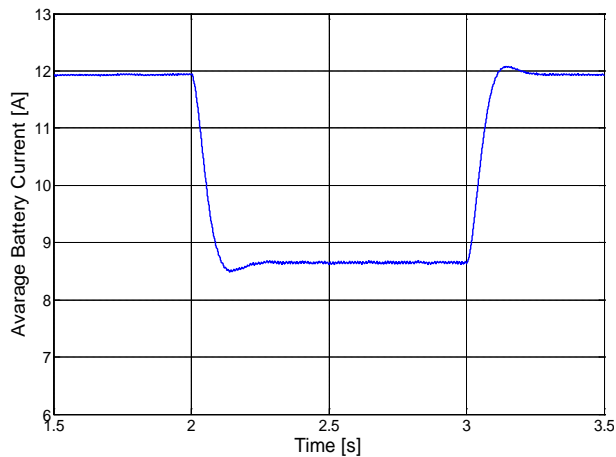

Fig. 12 The average battery current

While an additional load is connected, the average battery current decreases from 12A to about 8.5A.

5 Conclusion

The proposed wind stand-alone system is dedicated to a residential location and is able to supply single-phase consumers of 230V and 50Hz. The control of a variable speed PMSG for wind generation system is based on the MPPT method and has been presented in this paper. The start-up process begins when the wind velocity exceeds the threshold value of 4m/s. The turbine-generator speed is controlled by the buck-boost converter, which acts as a maximum power point tracker. The balance between the generated power and the consumed power is maintained by an electrical battery or by the dump load. The load variations are well managed and the dynamic performance is good.

References:

- [1] L. Barote, L. Clotea, "MPPT control of a variable - speed wind turbine", Bulletin of the Transilvania University of Brasov, vol. 13, series A1, ISSN 123-9631, Brasov, Romania, pp. 195-201, 2006.
- [2] L. Barote, C. Marinescu, M. Georgescu, "VRB modeling for storage in stand-alone wind energy systems", Proc. of the Power Tech'09 IEEE Conference, ISBN: 978-1-4244-2235-7, Bucharest, Romania, pp. 1-6, June/July, 2009.
- [3] L. Barote, M. Georgescu, C. Marinescu "Smart storage solution for wind systems", Proc. of the Power Tech'09 IEEE Conference, ISBN: 978-1-4244-2235-7, Bucharest, Romania, pp.1-6, June/July, 2009.

- [4] M. Georgescu, "Electrical energy storage systems", Romanian Research National Center, Tech. Rep., Projects IDEI 134/2007 and e-FARM 22134/2008, Nov. 2008A1, ISSN 123-9631, Brasov, Romania, pp. 195-201, 2006.
- [5] L. Barote, R. Weissbach, R. Teodorescu, C. Marinescu, M. Cirstea, "Stand-Alone Wind System with Vanadium Redox Battery Energy Storage", IEEE, International Conference on Optimization of Electrical and Electronic Equipments, OPTIM'08, 22-24 May, Brasov, Romania, 2008, pp. 407-412.
- [6] Energy output, *The Weibull distribution*, Danish Wind Industry Association, 19 September 2003, <http://www.windpower.org/en/tour/wres/weibull.htm>
- [7] Ned Mohan, *Power electronics converter, application and design*, 2nd edition, chapter 5 pages 79-114, John Wiley & Sons Ltd, ISBN 0-7923-7270-0.
- [8] L. Barote, *Small Wind Generation System with Storage*, Scientific report, Aalborg University, June, 13st 2008, Denmark.

Creative Commons Attribution License 4.0 (Attribution 4.0 International, CC BY 4.0)

This article is published under the terms of the Creative Commons Attribution License 4.0
https://creativecommons.org/licenses/by/4.0/deed.en_US