

Circular and Dual Polarized Antenna for Self-Interference Cancellation in the Next Generation of Mobile Communication Networks

MOHAMED B. EL-MASHADE & EHAB A. HEGAZY

Electrical Engineering Dept., Faculty of Engineering, Al Azhar University, Nasr City, Cairo, EGYPT

Abstract: The interference phenomena is actually appeared in all current wireless communication systems. This problem has different forms and impacts the performance of any wireless system. At the present time, a new technology, that is called fifth generation (5G), of mobile communications knocks the doors to be commercial within few days. Conventional wireless communication systems use two separate channels, one channel to transmit and another to receive. Achieving single channel full duplex (FD) is one of the key challenges for 5G implementation. Single channel FD provides the capability of sending and receiving concurrently over the same channel, along with assuring efficient utilization of the available spectrum. With this newest technology, another sort of interference will be generated which is called self-interference (SI). SI cancellation techniques represent an awesome solution for the development of next generation. These techniques have two types: passive and active cancellation. Antenna cancellation approach can be characterized as a passive cancellation. In our proposed work, antenna with two feedings is employed as a cancellation procedure. A patch antenna is simulated and tested for two resonance frequencies, 2.45GHz and 28.0GHz. Both frequencies are candidates of frequency channel proposed by ITU for the fifth generation of mobile networks. Finally, the complete design and simulation of dual polarized, with series-fed 3 by 3 patch array on 3.3GHz, is provided.

Keywords: Self-Interference Cancellation, Fifth Generation, Dual Polarized Antenna, Antenna Design, Patch Array Antenna.

Received: September 28, 2020. Revised: February 6, 2021. Accepted: February 19, 2021. Published: February 25, 2021.

1. Introduction

Since the initiation of the first generation in 1980, mobile communication technology has numerous expansions till the appearance of fourth generation in 2010. Through these years, the end user has different kinds of wireless services. The current versions of mobile communication systems offered many services such as voice calls, text message, video conference, web browsing, and HD mobile TV with higher data rates. Nevertheless, there is a growing request for that rate to be better and higher. Hence, seeking for next evolution is necessary to reply the customer needs. Fifth generation is predicted to empower the service providers to establish a complete connection with network [1-2]. Additionally, it has more services that must be provided, as advanced data volume per region, massive number of connected handset, and decreasing the end-to-end latency. Moreover, user data rate is expected to be 10 to 100 times higher than the present models.

Usually, the existing wireless communication systems use two different channels to complete their processing of operation. Transceiver process, as in all available mobile systems, can't send and receive on the same frequency channel/time slot. In addition, transmission mode isn't evolved, even LTE (long term Evolution) is still continuing via frequency division duplex (FDD) or time division duplex (TDD). Achieving single full duplex will give us a great chance for the future of 5G to be more practicable. Also, it leads to adequate utilization for the allowable spectrum. Unfortunately, through exploiting the pronounced merits of single channel and eliminating the frequency and time

constraints, self-interference(SI) is emerged as a surprising challenge. Transmitted antenna is the source of this kind of interference due to its high power [3].

The intensity of SI is an important factor due to its worse impact on the wireless communication system performance. Hence, it is of great importance to cancel or even mitigate the effects of this unwanted phenomena. For this objective, the self-interference cancellation (SIC) techniques propose a smart approach to overcome this problem and enhance the usage of the current spectrum. Generally, SI cancellation techniques act as a backbone for the deployment of single channel in the forthcoming versions of mobile networks. The cancellation of SI should be executed via antenna scheme, RF fragment, and analogue as well as digital signal processing. SI cancellation can be formulated in two main forms. The first one is correlated to electromagnetic separation and is termed as passive cancellation, whilst the second one can be called as active cancellation [4].

An antenna system can be considered as the eye of each wireless communication system. Here, with the existing of self-interference problem, an antenna acts as a foremost part in passive self- interference cancellation procedure. According to the summary in [5], an antenna has been implemented in each model of cancellation. Here, our proposal offers two different designs: one is devoted to a single antenna with dual feed and the other is concerned with a cross or dual polarized patch array antenna. In this research, we select three resonance frequencies. They are 2.45GHz, 28GHz, and 3.3GHz. These frequencies are considered as candidates in the channel

frequency band proposed by international telecommunication union (ITU) for the future of fifth generation.

The remainder of this paper is organized as follows. In Section 2 self-interference cancellation techniques are overviewed. In Section 3, the proposed technique, design, objectives and physical parameters of patch antenna are discussed. Section 4 presents the outcomes and simulation results. Finally, our conclusions are summarized in section 5.

2. Classification of self-interference Mitigation

At the start, we will give a global picture for the first category of SI management which is called domain based [6] as Fig.(1) depicts.

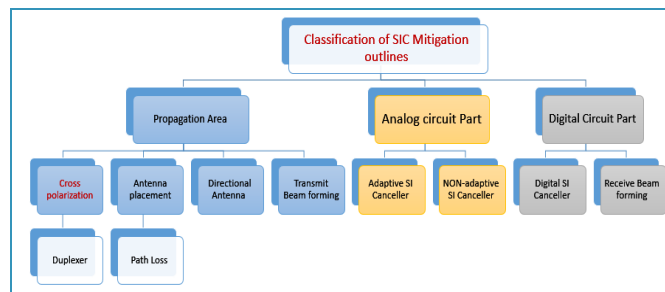

Fig.1 Outlines of SI classification

2.1 Propagation Area

In wireless-propagation-area, the isolation techniques are to electromagnetically isolate the transmit chain from the receive chain. In other words, the self-interference mitigation must be done before it makes plain in the received chain circuitry. The most important advantage of carrying out self-interference mitigation in the propagation area is that the downstream receiver hardware doesn't requisite to faithfully process signals with a big dynamic range [5, 6]. In this state of SI mitigation, an antenna is playing a vital role and it can be allocated into different forms or it can be used in different arrangements. In this regard, a single antenna can be employed for transmitting and receiving, and implement some forms of duplexing based on the direction of travel of signals at the antenna port. In addition, multi-antenna model can be deployed through the use of separate transmitting and receiving antennas to obtain isolation due to the propagation loss between the antennas. Moreover, there is another antenna based isolation technique via using several transmitting antennas, and organizing the receiving antennas in such a way that they are placed in positions where the signals from the transmit antennas interfere destructively [7]. Furthermore, cross-polarization introduces a supplementary mechanism to electromagnetically isolation. Polarization diversity can give the terminal the chance to transmit only horizontally polarized signals and receives only vertically polarized signals with the goal of avoiding interference between them [8].

2.2 Analog Circuit Part

In analog-circuit-part, the mitigation techniques aim to reduce SI in the analog circuitry of the receiving chain and before the ADC. This reduction may arise either before or

after the down converter and the LNA. Analog circuit models can be categorized as either adaptive or non-adaptive depending on their abilities to respond to changing effects of the environment [9]. The adaptive active analogue mitigation techniques dynamically regulate their parameters conferring to the reflected channel and are capable to mitigate both direct-path and reflected SI signals. RF Balun can be considered as an example for the adaptive analogue scheme, as this procedure uses signal inversion technique for SI mitigation [10]. On the other hand, the non-adaptive schemes are not environment aware. In other words, they are sensitive to reflected paths of SI because they aren't aware of the changes in the environments [11]. Hence, it is of importance, through the using of these schemes, to perform some manual tuning as well as use fixed parameters such as gain, delay and phase in predicting SI. The noise canceller chip QHx220 is playing an interesting role and can be considered as an example for non-adaptive analog circuit mechanism.

2.3 Digital Circuit Part

In digital part, the mitigation techniques aim to deal with the self-interference after the ADC through introducing sophisticated digital signal processing (DSP) techniques to the received signal. It is identified in collected work in which digital SI canceller (DSC) and transmit beam forming are procedures that could be assumed in digital part to actively suppress residual SI that might have escaped from the passive and analogue circuitry. The main merit of working in the digital area is that sophisticated processing is relatively easy. Digital mitigation is one of the lowest complexity self-interference mitigation techniques in full-duplex systems. However, its mitigation ability is very limited, mainly due to transmitter and receiver circuit's impairments [12].

SI cancellation techniques familiarize as a best solution to upcoming version of the next generation of mobile communication, through achieving single channel. Traditional editions of mobile communication systems have the proficiency of choice since it can turn as transceiver concurrently either on the same frequency segment with time varying (TDD) or on another frequency resource (FDD) [13]. SI cancellation techniques have several types. However, most research work announced that cancellation techniques have two forms which are termed as passive and active cancellations [14]. Passive cancellation technique is employed on the level of an antenna module. Meanwhile, active cancellation technique employs a major part which includes both analogue and digital processes. Active cancellation can be implemented via combination of RF segment and digital processing. This scenario can be considered as collation technique that relies on subtracting the SI signal from the received one. The subtraction method will be employed via digital samples and analogue signal. Several types of active SI cancellation are found in literature [15]. In FD system, an active SIC can be achieved via balanced to unbalanced transformation, which is termed as a balun. An inverse SI signal, which is the amount produced by balun, will be expedient to revoke SI. Balun will obtain a positive signal

from transmitted antenna, which causes SI signal. In order to match the received signal, a combination process will be applied for both received and inversed signals. In addition, some adjustments, such as delay and attenuation, can be employed on an inverse signal. According to [16], Table I displays a small summary for RF solution in SIC approaches.

Table 1. Antenna used in accordance with specified technique

RF SIC Techniques	NO, of Antennas
Combination of a variable attenuator and phase shifter	One general
Fed-forward cancellation with two fed	One specific
Balanced/unbalanced (balun) transformer	2Antennas
Antenna cancellation using two transmit and one receive antennas	3 Antennas
1) QHx220 noise cancellers 2) annulling transmit antenna	2 Antennas
1) QHx220 noise cancellers 2) Transmit antenna 3) digital cancellation	3Antennas

QHx 220 noise suppression chip is used to eliminate known analogue interference signal from the received signal [10]. This chip takes the recognised self-interference and received signals as inputs and outputs the received signal with the self-interference subtracted out. It permits changing in the amplitude and phase of the interference reference signal to contest the interference in the received signal. It is required to feed the signal from the transmit antenna, via a wire, to the QHx220 and connected it to the receiving antenna. Through the employment of QHx220 noise canceller, a subtraction process is applied to both interfering signal and received signal to improve the beneficial signal [17]. Other method for self-interference cancellation is implemented to eliminate SI in the analogue signal stage according to the phase of the two signals.

3. Antenna cancellation

An antenna system can be considered as the backbone of each wireless communication system. Here, with the existing of self-interference problem, an antenna acts as a foremost part in passive self-interference cancellation technique. According to the summary presented in table 1, we can see that an antenna plays a very important role in the deployment of each model for self-interference cancellation. In our proposed work, two different designs are presented. They include a single antenna with dual-fed in addition to employ a cross or dual polarized patch array antenna. Three resonance frequencies are selected in our design. They are 2.45GHz, 28GHz, and 3.3GHz. These frequencies are candidates in ITU frequency band devoted to the future of fifth generation.

An antenna has the ability for transmitting and getting signals by means of polarization diversity. It is significant to note that feeding spots are orthogonal and have similar amplitude. Aiming that our proposed work will be useful for future of 5G via feeding an antenna with 2 orthogonal amplitude. Also, according to spectrum consideration of 5G and since a cross polarization can support in the mitigation of SI on antenna level, we will employ a cross or dual polarization patch array antenna with 3.3GHz.

3.1 Working Mechanism of SI Mitigation through a balanced feed network

This subdivision specifies the operation of a single antenna bi-directional configuration employed with a balanced feed network which is capable of simultaneously mitigating the antenna reflection and circulator leakage. As Fig.(2a) shows, the feed network consists of two quadratic hybrids connected to a single CP patch antenna and two circulators. In this regard, we are interested in that type which provides an equal power split and 90° relative phase difference.

At first, we will give a global picture of the working principle of quadrature hybrid. Generally, hybrid couplers are special cases of directional couplers, where the coupling factor is 3dB, which implies that $\alpha = \beta = 1/\sqrt{2}$. Quadrature hybrid has 4 ports which are defined as 1, 2, 3 and 4. In this vein, if port 1 acts as an input, then the output will accomplished through ports 2 and 3 with 90° phase difference, while port 4 is isolated. The balanced feed network (BFN) is constructed to combine reflected signals from the two antenna ports in such a way that these signals are 180° out of phase when they arrive at the Rx output and cancel each other [18]. As Fig.(2b) depicts, the input Tx signal is equally divided into two separate paths and travels through the network. This separation process is done through the 1st quadrature hybrid, which it will give two equal-amplitudes with 90° phase shift, and then the Tx signals pass through the two circulators and enter the antenna.

1st path: highlighted in dashed line

a) Via quadrature hybrid #1 = $\frac{j}{\sqrt{2}}V$

b) continue through top circulator = $\frac{j}{\sqrt{2}}V \sqrt{1 - |B|^2}$

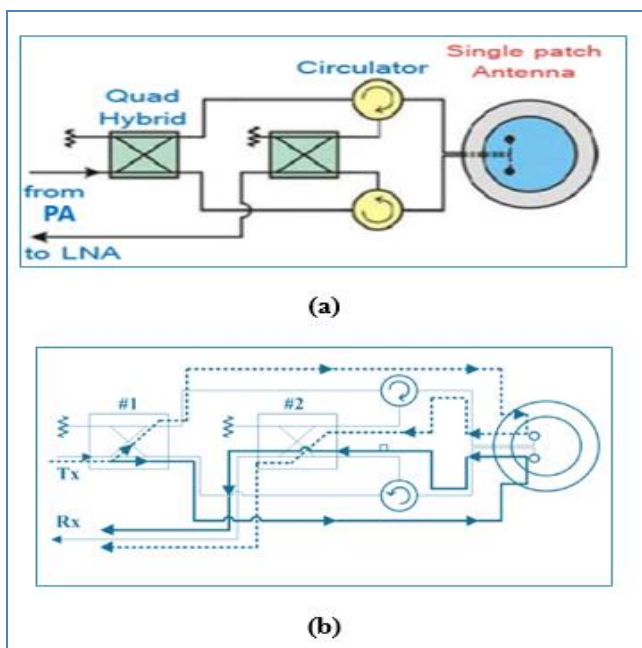

Fig. 2 Patch antenna for passive cancellation with two feds

- c) reflected from antenna = $|\Gamma|e^{j\phi} \left(\frac{j}{\sqrt{2}}V\sqrt{1-|B|^2}\right)$
d) back through the top circulator = $|\Gamma|e^{j\phi} \left(\frac{j}{\sqrt{2}}V(1-|B|^2)\right)$
e) continue through hybrid #2 to Rx = $|\Gamma|e^{j\phi} \left(\frac{j}{\sqrt{2}}V(1-|B|^2)\right)$

2nd path: highlighted in solid line

- a) Via quadrature hybrid #1 = $\frac{1}{\sqrt{2}}V$
b) continue through Bottom circulator = $\frac{1}{\sqrt{2}}V\sqrt{1-|B|^2}$
c) reflected from antenna = $|\Gamma|e^{j\phi} \left(\frac{1}{\sqrt{2}}V\sqrt{1-|B|^2}\right)$
d) back through the Bottom circulator = $|\Gamma|e^{j\phi} \left(\frac{1}{\sqrt{2}}V(1-|B|^2)\right)$
e) continue through hybrid #2 to Rx = $|\Gamma|e^{j\phi} \left(\frac{1}{\sqrt{2}}V(1-|B|^2)\right)$

Thus, the total power of SI output at Rx can be written as:

$$-|\Gamma|e^{j\phi} \left(\frac{1}{\sqrt{2}}V(1-|B|^2)\right) + |\Gamma|e^{j\phi} \left(\frac{1}{\sqrt{2}}V(1-|B|^2)\right) = 0$$

On the other hand, a percentage part of the Tx signals is reflected back into the network with a reflection coefficient $|\Gamma|e^{j\phi}$. The reflected signals pass through the two circulators and are routed to the two inputs of the second quadrature hybrid. The second hybrid combines the two signals which are now 180° out of phase at the output port of the hybrid connected to the Rx. In the following portion, the analysis for the mitigation of the reflected signals at the output to the network is illustrated.

Firstly, let us consider that the antenna port reflection coefficient is defined as $|\Gamma|e^{j\phi}$ and the amplitude of the leakage through the circulators is defined as |B|. Also, for simplicity of the analysis, it is assumed that the quadrature hybrids, circulators and connecting transmission lines are lossless. Additionally, the transmission phases of the direct and reflected paths are assumed to be zero even though any entered phase value will still work as long as the phase balance is maintained through the network.

4. Proposed Antenna Design Configuration

With referring to design specification, three factors are vital in order to complete the plan of a patch antenna. They are the operating frequency (f_r), the substrate dielectric constant (ϵ_r) and the dielectric substrate height (h).

Firstly, we will calculate the antenna width which can be expressed as:

$$W = \frac{c_9}{2f_r} \sqrt{\frac{1}{\epsilon_r}} \quad (1)$$

The effective dielectric constant ϵ_{reff} expression can be estimated as:

$$\epsilon_{reff} = \frac{\epsilon_r + 1}{2} + \frac{\epsilon_r - 1}{2} \left(\frac{1}{\sqrt{1 + 12 \frac{h}{W}}} \right), \quad \frac{W}{h} > 1 \quad (2)$$

For a given resonance frequency f_r , the effective length is given by:

$$L_{eff} = \frac{c_0}{2f_r \sqrt{\epsilon_{reff}}} \quad (3)$$

The extension in length (ΔL_{eff}) can be estimated as:

$$\frac{\Delta L_{eff}}{h} = 0.412 \frac{(\epsilon_{reff} + 0.3) \left(\frac{W}{h} + 0.264\right)}{(\epsilon_{reff} - 0.258) \left(\frac{W}{h} + 0.8\right)} \quad (4)$$

Then, the actual length calculation becomes:

$$L = L_{eff} - 2\Delta L_{eff} \quad (5)$$

The proposed antenna feeding is accomplished through a micro strip line technique. In our proposed antenna, we will calculate both the length and width of the matching transmission line which are defined as **Lm1** and **Wm1** for port one. Meanwhile, both the calculated length and width of feed micro strip line are computed and are defined as **Lt1** and **Wt1** for the same port. The design is performed according to Micro strip patch antenna rules in [12-15]. Also, similar processing is done for port 2.

4. 1 Simulation results of the proposed antenna

The analysis and performance of the antenna are carried out by using CST software [16].

Subdivision 1

The proposed patch antenna operates at 2.45GHZ with 1.5mm substrate height.

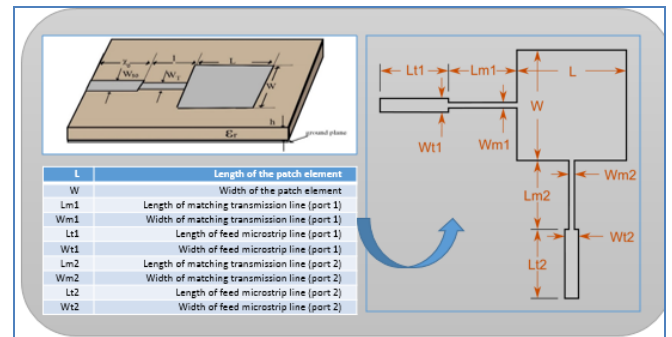

Fig. 3 Dual micro strip-edge-fed circularly polarised rectangular patch

Fig.(3) illustrates the design specifications of the tested patch antenna. It shows dual-fed circularly polarized patch design with objectives, indicated in Table 1. Table 2 describes the physical parameters of our proposed design.

Table 1 Dual-fed circularly polarised patch design objective

Name	Description	Value
f_0	Centre frequency	2.45 GHz
R1	Input resistance at port 1	50 Ω
R2	Input resistance at port 2	50 Ω
P	Polarization (transmitting)	linear
Name	Substrate: the substrate material name	FR-4

Table 2 Dual-fed circularly polarised design parameters

Name	Description	Value
L	Length of the patch element	26.11 mm
W	Width of the patch element	29.01 mm
Lm1	Length of matching transmission line (port 1)	18.18 mm
Wm1	Width of matching transmission line (port 1)	159.7 μm
Lt1	Length of feed micro strip line (port 1)	16.84 mm
Wt1	Width of feed micro strip line (port 1)	2.892 mm
Lm2	Length of matching transmission line (port 2)	18.18 mm
Wm2	Width of matching transmission line (port 2)	159.7 μm
Lt2	Length of feed micro strip line (port 2)	16.84 mm
Wt2	Width of feed micro strip line (port 2)	2.892 mm

Scattering parameters of an antenna can be defined as the correlation or the relationship between ports. For case in point, the S12 represents the power transferred from Port 2 to Port 1 and S21 denotes the same thing from Port 1 to Port 2. Fig.(3) shows S12 and S21 of the reference antenna, as function of frequency. In other way, this figure presents a high isolation between the two ports. S12 and S21 are of values around 34dB. The antenna bandwidth and average values of S12 and S21 are indicated in Table 3.

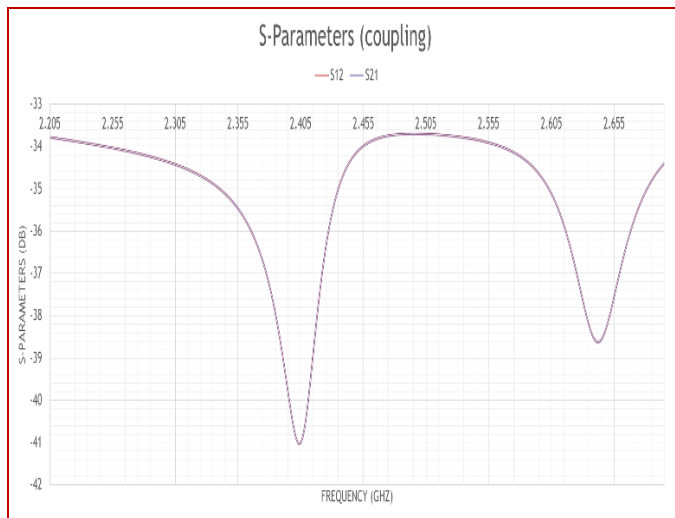

Fig.3 S12 and S21 of the patch antenna resonating at 2.45GHz

Table 3 Average S-parameters Dual-fed circularly polarised antenna

Dual port antenna 2.45GHz		
	S12	S21
Average S-parameters	-35.17 dB	-35.17 dB
Bandwidth below(-10dB level)	490MHZ	490MHZ

In the upcoming part, we will explore the antenna performance parameters such as radiation pattern, gain and axial ratio. The radiation pattern of an antenna is an indication of the far-field radiation characteristics of that antenna as a function of the angle of elevation θ and the azimuth angle Φ . More specifically, it is a plot of the radiated power from an antenna per unit solid angle. Figs.(4a & 4b) depict the far field gain of a proposed antenna at $\Phi = 0^\circ$ and $\Phi = 90^\circ$. As demonstrated in Fig.(5), the proposed antenna achieves an accepted radiation pattern with directivity of about 7.221dBi.

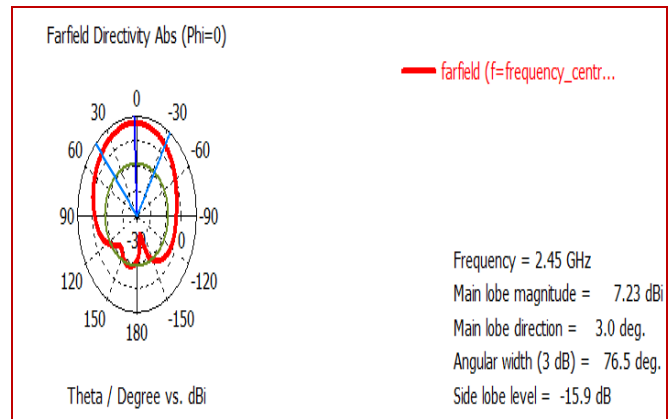

Fig.4a Dual microstrip-edge-fed circularly polarised patch antenna radiation pattern for 2.45GHz at $\Phi = 0^\circ$

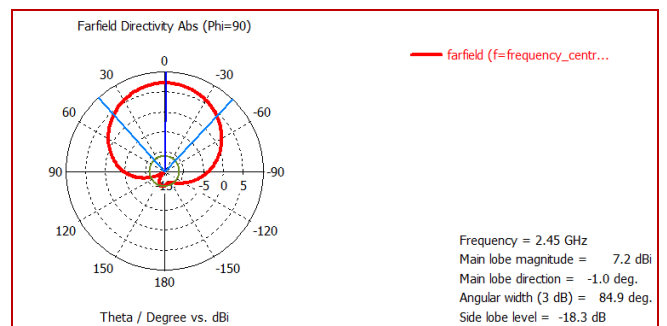

Fig.4b Dual microstrip-edge-fed circularly polarised patch antenna radiation pattern for 2.45GHz at $\Phi = 90^\circ$

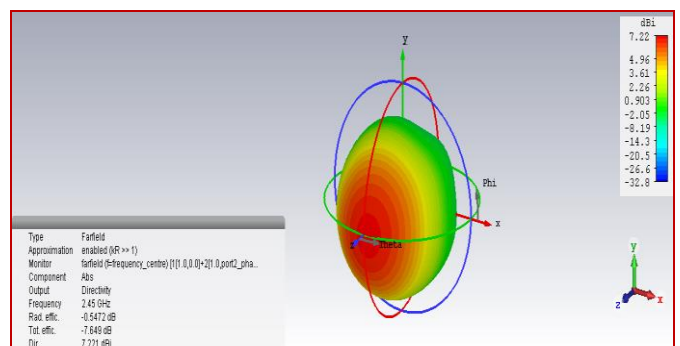

Fig.5 Dual micro strip-edge-fed CP radiation pattern plot

Figs.(6a & 6b) show far field versus angle for the designed frequency at $\Phi = 0^\circ$ and $\Phi = 90^\circ$.

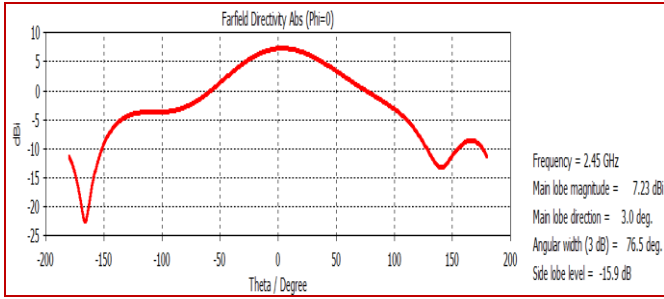

Fig.6a Far field versus angle plot at $\Phi = 0^\circ$

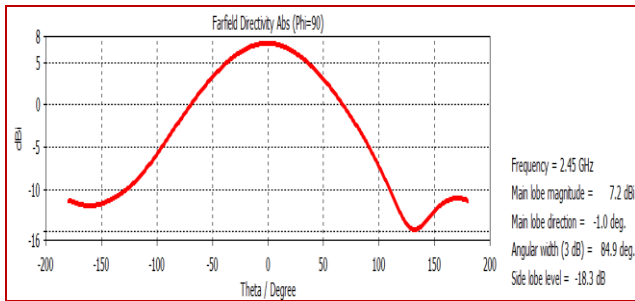

Fig.6b Far field versus angle plot at $\Phi = 90^\circ$

Subdivision II

Fig.(8) displays the proposed patch antenna designed at 28GHz resonance frequency, through the same design objectives as in the case of 2.45GHz, with 100 μ m substrate height.

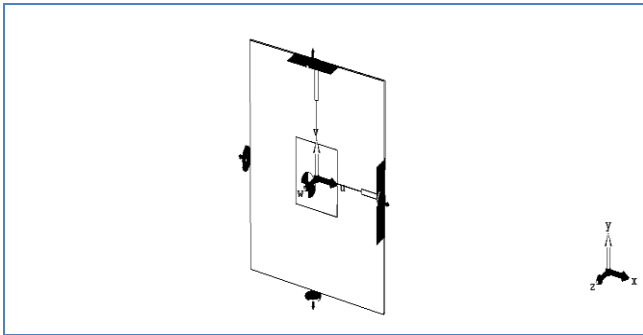

Fig.8 Dual micro strip-edge-fed CP patch antenna preview

The proposed antenna physical parameters are planned as Table 4 demonstrates.

Table 4 Design parameters of dual-fed circularly polarised antenna at 28GHz.

Name	Description	Value
L	Length of the patch element	2.503 mm
W	Width of the patch element	2.750 mm
Lm1	Length of matching transmission line (port 1)	1.592 mm
Wm1	Width of matching transmission line (port 1)	10.14 μ m
Lt1	Length of feed micro strip line (port 1)	1.474 mm
Wt1	Width of feed micro strip line (port 1)	192.8 μ m
Lm2	Length of matching transmission line (port 2)	1.592 mm
Wm2	Width of matching transmission line (port 2)	10.14 μ m

Lt2	Length of feed micro strip line (port 2)	1.474 mm
Wt2	Width of feed micro strip line (port 2)	192.8 μ m

Fig.(9) illustrates the estimated scattering parameters, S12 and S21, versus frequency of the proposed patch antenna. The values of these s-parameters are around 36.762dB. The polar plots at $\Phi = 0^\circ$ and $\Phi = 90^\circ$ are shown in Figs.(10a & 10b). In Table 5, we indicate the antenna bandwidth and average values of S12 and S21.

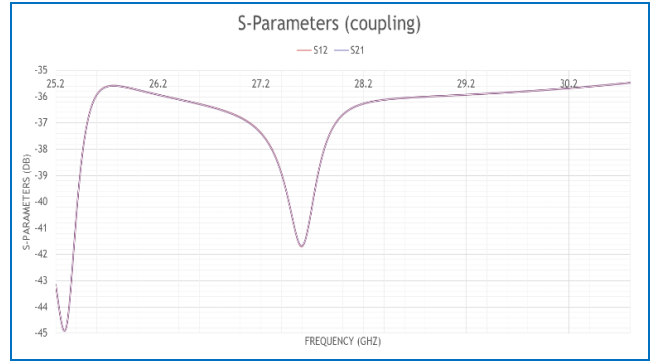

Fig.9 Scattering parameters (S12, S21) of circularly polarised patch antenna radiation pattern at 28GHz

Table 5 Average S-parameters Dual -fed circularly polarised antenna

Dual port Antenna 28 GHZ		
	S12	S21
Average S-parameters	-36.75 dB	-36.75 dB
Bandwidth below(-10dB level)	5.6GHZ	5.6GHZ

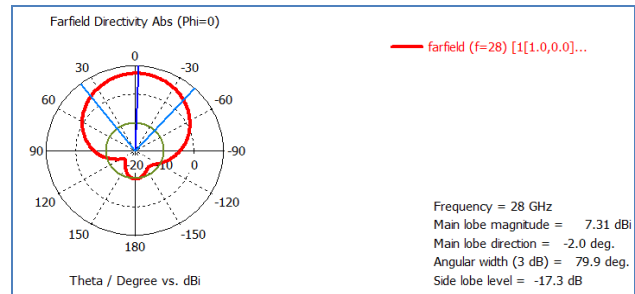

Fig.10a Dual microstrip-edge-fed circularly polarised patch antenna radiation pattern for 28GHz at $\Phi = 0^\circ$

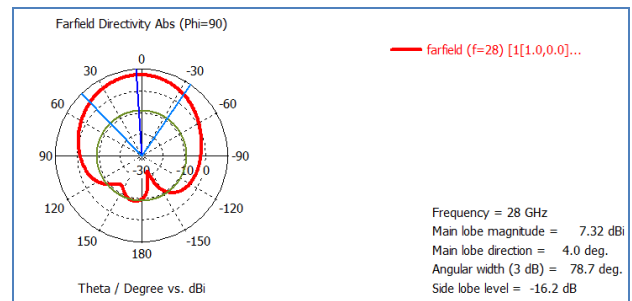

Fig.10b Dual microstrip-edge-fed circularly polarised patch antenna radiation pattern for 28GHz at $\Phi = 90^\circ$

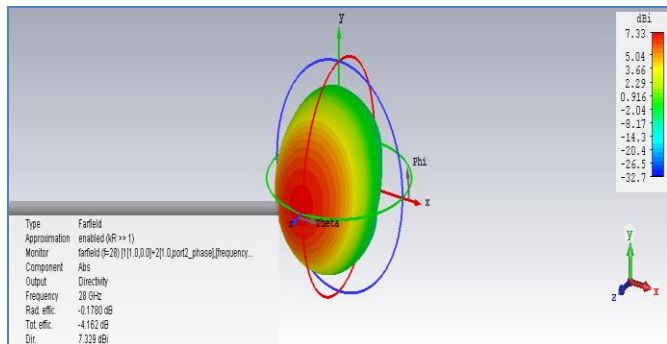

Fig.11 Dual micro strip-edge-fed CP radiation pattern plot

As revealed in Fig.(11), the proposed antenna attains an acceptable radiation pattern with directivity of about 7.329dBi.

Fig.(12a) and Fig.(12b) illustrate far field versus angle for the designed frequency at $\Phi = 0^\circ$ and $\Phi = 90^\circ$, respectively.

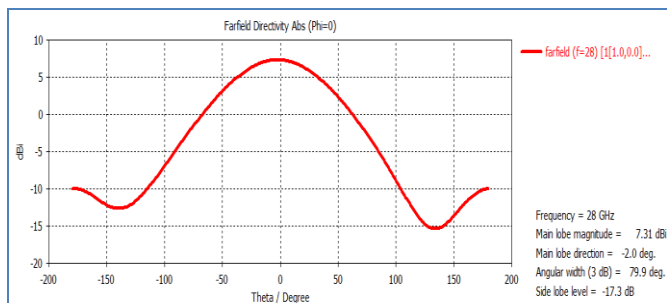

Fig.12a Far field versus θ at $\Phi = 0^\circ$

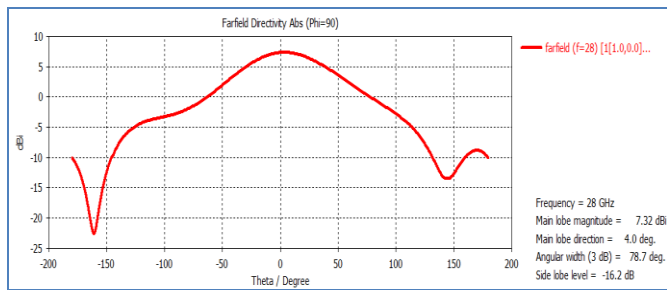

Fig.12b Far field against angle θ at $\Phi = 90^\circ$

Our proposed antenna has the ability to transmit and receive signals by means of polarization diversity. It is significant to note that feeding spots are orthogonal and have similar amplitude. Table 6 summarizes the main parameters used in our design along with the gain of each antenna in terms of the resonance frequency.

Table 6 Directivity for Dual-fed circularly polarised antenna

Dual port Antenna		
	2.45GHz	28GHz
Dielectric substrate	FR-4	FR-4
Substrate permittivity (ϵ_r)	4.35	4.35
substrate height	1.5mm	100 μ m
Antenna gain(directivity)	7.221dBi	7.329dBi

Proposed work is considered as one of SIC techniques which is already used to reduce the intensity of SI in wireless systems and to overcome the limitations of full duplex communication via effective propagation isolation between the transmitted and received signals. Numerous dissimilar cancellation practices are shortened in [18], which emphasized on the amount of self-interference that can be annulled for each approach. They revealed that, through their type of SIC which is called antenna isolation technique, they can provide isolation in the range from 20dB to 30dB. In our proposed antenna, we succeeded to achieve isolation between ports around 34dB at 2.45GHz, and around 36dB at 28GHz.

Subdivision III

According to 5G spectrum consideration, most mobile and wireless systems currently operate on below 6GHz Spectrum. Besides achieving high data rates, it is also necessary to guarantee wide area and outdoor to indoor coverage in 5G. Therefore, spectrum below 6GHz represents a very important part of the 5G spectrum solution. Moreover, federal communications commission (FCC) takes action to make additional spectrum available for 5G services. Furthermore, the main challenge encountered in implementing full duplex wireless devices is that of finding techniques for mitigating the performance degradation caused by self-interference. Self-interference suppression will represent one of the main problems that must be overcome in the 5G Networks. In the existing version of mobile networks, the available spectrum is not sufficiently used. Whilst in the predicted version, the spectrum is required to be employed in a more efficient manner in such a way that it will be approximately full all of the operating time.

Cross-polarization is suggested as a solution to some of the above mentioned problems. It is a mechanism of electromagnetically isolation for the in-band full duplex (IBFD) transmit and receive antennas. In other words, one may build an IBFD terminal that transmits only vertically polarized signals and receives only horizontally polarized ones with the objective of avoiding interference between them. Also, the mm-wave technology permits the improvement of a compact antenna, which significantly reduces the antenna's size. The resulting compact antenna allows us to use multi-elements for transmission and several ones for receiving which in literature known as multi-inputs multi-outputs (MIMO) technology. There are numerous performance challenges in the mm-wave MIMO antenna design such as mutual coupling, greater gain, comprehensive bandwidth, and extraordinary radiation efficiency. On the

other hand, MIMO mm-wave antenna has some merits such as spatial multiplexing which is the responsible of increasing capacity and link stability.

Conferring to design specification, there are three vital parameters to complete the plan of a patch array antenna. They are the operative frequency f_r , substrate dielectric constant ϵ_r and the dielectric substrate height h . The proposed patch antenna operates at 3.3GHz using FR-4 with 1.5mm and 4.35 for substrate height and dielectric constant, respectively. Also, the loss tangent ($\tan\delta$) is 0.01. The dual polarized with series-fed 3 by 3 micro strip patch array lay out is depicted in Fig.(13).

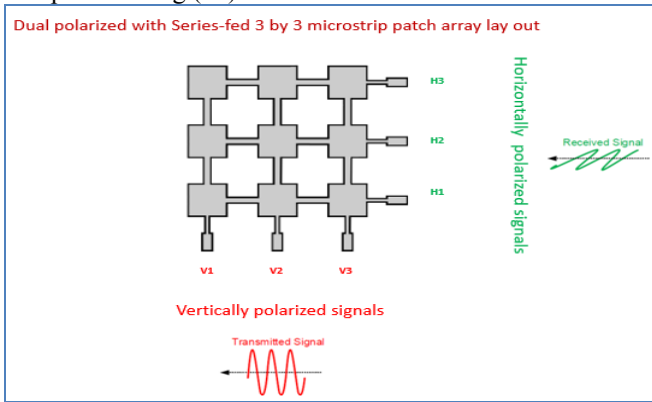

Fig.13 Dual polarized micro strip patch array lay out

The objectives of such antenna configuration are presented in Table 7 and the physical parameters of our proposed design is tabulated in Table 8.

The performance of the proposed antenna configuration, which is intended to achieve high isolation and it can support to MIMO mm-wave application, is explicitly assessed in terms of simulation results. This MIMO antenna's performance includes return loss, mutual coupling, gain and directivity.

Table 7 Dual polarized patch design objective

Name	Description	Value
f_0	Centre frequency	3.3 GHz
Rin	Input resistance	50 Ω
P	Polarization (transmitting)	linear
Name	Substrate: The substrate name.	FR-4
Dielectric constant	Dielectric constant of FR-4 Substrate	4.35
$\tan\delta$	Loss tangent	0.01

Table 8 Dual polarized design parameters (3.3GHz)

Name	Description	Value
Lh	Patch length horizontal	21.10 mm
Lv	Patch length vertical	21.10 mm
Wm	Matching line width	417.4 μm
Lm	Matching line length	13.27 mm
Wf	Feed line width	2.892 mm
Lf	Feed line length	12.51 mm
Ll	Line length	24.73 mm
Wl	Line width	2.109 mm
H	Substrate height	1.5 mm

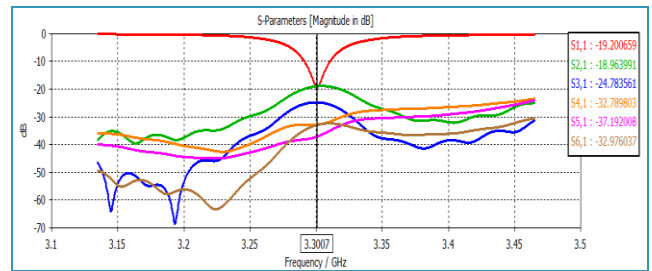

Fig.14 Scattering parameters for dual polarized micro strip patch array

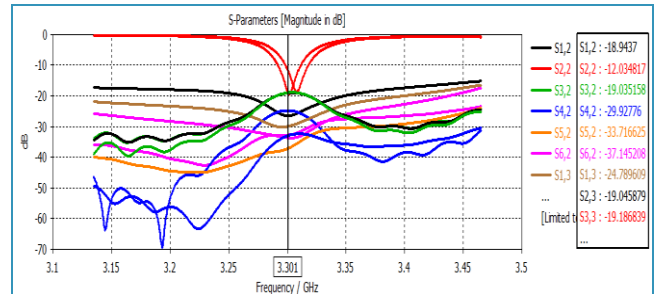

Fig.15 Scattering parameters for dual polarized micro strip patch array

As figures 14 and 15 presented, the simulated S-parameters of the proposed dual polarized with series-fed 3 by 3 micro strip patch array antenna achieve an accepted values for each port. Also, the mutual coupling values (S_{21} , S_{31} , S_{41} , S_{51} , S_{61}) of the proposed antenna configuration are acceptable and of highly isolation.

Usually, return loss (RL) can be defined as a measurement of how well the antenna and the transmission lines are matched. In the matched system, high return loss and lower insertion loss are desirable. The return loss is formulated as $(dB) = 10 \log_{10} (P_i / P_r)$ with P_i as the incident power and P_r as the reflected power. The return loss is related to standing wave ratio (SWR), where increasing return loss corresponds to lower SWR. In other words, return loss for an antenna is very important parameter, which specifies the lost in the amount of power. RL value is reliant on the matching impedance

between transmitter and antenna. Hence, RL is similar to VSWR parameter and indicates how proficiently an antenna operates over the designed range of frequencies to ensure accepted performance.

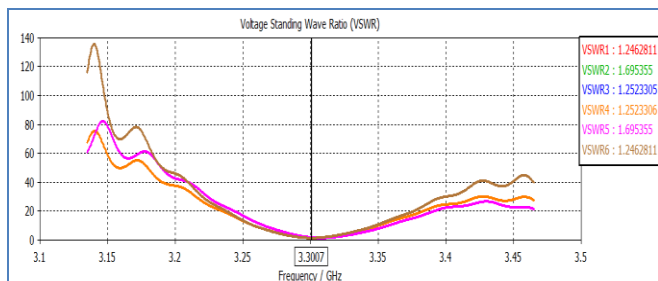
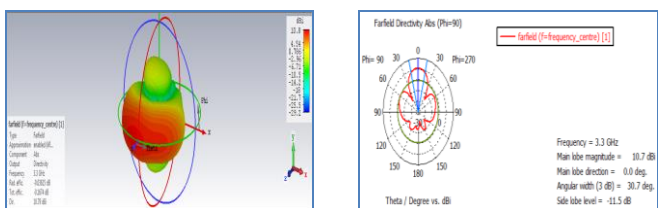

Fig.16 VSWR values for dual polarized micro strip patch array

In general, a VSWR range is less than or equal to 2. Also, the acceptable range for the return loss is greater than or equal to -9.5 dB. These values are standards to ensure acceptable performance for antenna design. In our design at 3.3GHz, it is noted that the obtained values of VSWR are within the acceptable range as Fig.(16) demonstrates.

In the upcoming portion, the far field gain of the proposed dual polarized with series-fed 3 by 3 micro strip patch array antenna at $\Phi=90^\circ$ in conjunction with the constructed radiation pattern (3D) along with directivity for each port are portrayed in Figs.(17-22).



(a) 3D pattern of dual polarized micro strip patch array (b) Dual polarized patch array radiation pattern at $\Phi=90^\circ$
 Fig.17 Dual polarized micro strip patch array far field for port 1

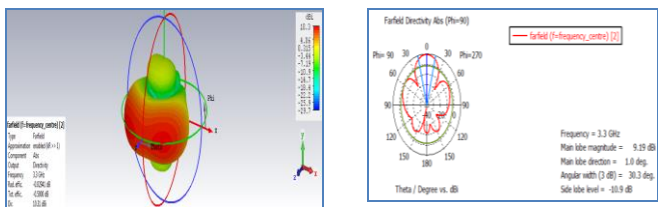

(a) 3D pattern of dual polarized micro strip patch array (b) Dual polarized patch array radiation pattern $\Phi=90^\circ$
 Fig.18 Dual polarized micro strip patch array far field for port 2

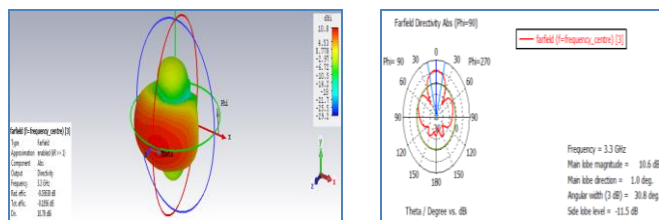

(a) 3D pattern of dual polarized micro strip patch array (b) Dual polarized patch array radiation pattern at $\Phi=90^\circ$
 Fig.19 Dual polarized micro strip patch array far field for port 3

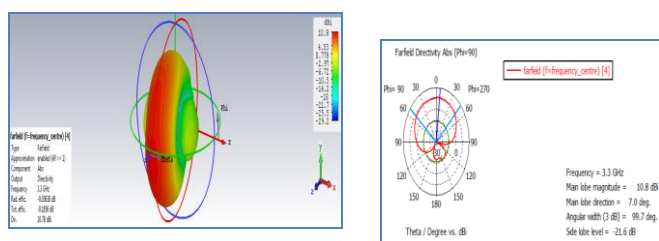

(a) 3D pattern of dual polarized micro strip patch array (b) Dual polarized patch array radiation pattern at $\Phi=90^\circ$
 Fig.20 Dual polarized micro strip patch array far field for port 4

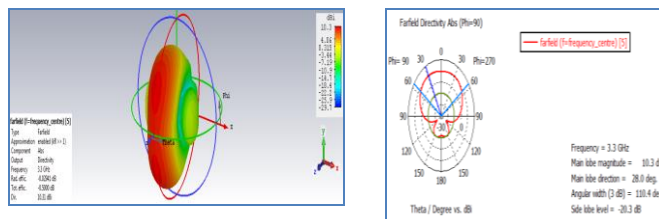

(a) 3D pattern of dual polarized micro strip patch array (b) Dual polarized patch array radiation pattern $\Phi=90^\circ$
 Fig.21 Dual polarized micro strip patch array far field for port 5

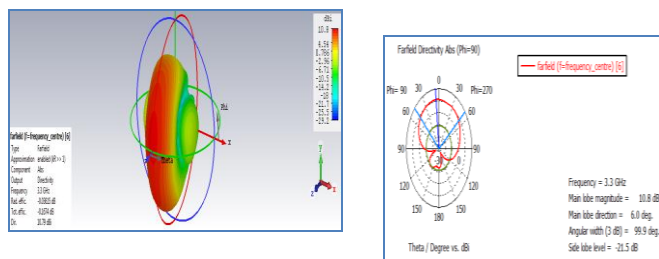

(a) 3D pattern of dual polarized micro strip patch array (b) Dual polarized patch array radiation pattern $\Phi=90^\circ$
 Fig.22 Dual polarized micro strip patch array far field for port 6

5. Conclusion

5G is predicted to provide attractive landscapes such as huge connections, reducing the latency down to 1ms and increasing data rate up to 10Gbps. Widening full duplex communication to a longer range could remain a primary challenge due to increasing the spectral efficiency along with more utilization of frequency spectrum. Achieving single channel full duplex remains one of the major challenges in 5G future. Self-interference cancellation is a mandatory and attractive solution for more utilization of the current spectrum. Numerous self-interference cancellation techniques are deployed in wireless systems, such as WIFI solution. Our proposed solution proved good results at 2.45 and 28GHz.

References

- [1] Kanupriya Singh, Sanjeev Thakur, Somya Singh, "Comparison of 3G and LTE with other Generation", *International Journal of Computer Applications*, Vol. 121, No.6, July 2015.
- [2] J. G. Andrews et al, "What will 5G be?" *IEEE J. Sel. Areas Commun*, Vol.32, pp.1065–1082, Jun. 2014.
- [3] J. Choi et al., "Achieving Single Channel, Full Duplex Wireless Communication", *ACMMOBICOM 2010*, Chicago, IL, 2010.
- [4] Michael. E. Knoxl, "Single Antenna Full Duplex Communications using a Common Carrier", *Wireless and Microwave Technology Conference (WAMICON)*, IEEE 13th Annual, April. 2012.
- [5] Laughlin L., Beach M. A., "Antennas and Radio Frequency Self-Interference Cancellation", Springer, Singapore, 2020. https://doi.org/10.1007/978-981-15-2969-6_1
- [6] E. Ahmed, A. M. Eltawil, and A. Sabharwal, "Self-Interference Cancellation with Phase Noise Induced ICI Suppression for Full-Duplex Systems", *Global Telecommunications Conference (GLOBECOM2013)*, Dec. 2013.
- [7] Jung II Choisy et al, "Achieving Single Channel, Full Duplex Wireless Communication", *Stanford University* 2010.
- [8] M. Jain et al, "Practical, Real-time, Full Duplex Wireless", *Proceeding of the ACM Mobicom*, Sept.2011.
- [9] N. Phungamngern, P. Uthansakul and M. Uthansakul, "Digital and RF Interference Cancellation for Single-Channel Full-duplex Transceiver Using a Single Antenna", *School of Telecommunication Engineering, Suranaree University of Technology Muang, Nakhon Ratchasima, Thailand* 2013.
- [10] Changyoung An, Heung-GyoonRyu, "Double Balanced Feed Network for the Self-Interference Cancellation in Full Duplex Communication System", *Wireless Pers Commun* (2017) 92:1599–1610 DOI 10.1007/s11277-016-3624-y.
- [11] Zhongshan Zhang et al, "Full Duplex Techniques for 5G Networks Self-Interference Cancellation, Protocol Design, and Relay Selection", *IEEE Communications Magazine* 2015.
- [12] Li Wang et al, "Exploiting Full Duplex for Device-to-Device Communications in Heterogeneous Networks", *IEEE Communications Magazine* 2015.
- [13] Balanis, C. A., "Antenna Theory: Analysis and Design", John Wiley & Sons, Inc New Jersey, 1997.
- [14] Yi. Huang and K. Boyle, "Antennas from Theory to Practice", John Wiley & Sons 2008, ISBN 978-0-470-51028-5
- [15] Mohamed B. El-Mashade, Ehab A. Hegazy, "Predicted Characteristics of 5G Version of Mobile Communication and Self-Interference Cancellation in Full Duplex Radio", *Electrical & Electronic Technology Open Access Journal*, Volume 1, Issue 1, pp. 1-8, 2017. DOI: 10.15406/eetoaj.2017.01.00005.
- [16] M. Jain, J. I. Choi, T. Kim, D. Bharadia, K. Srinivasan, S. Seth, P. Levis, S. Katti, and P. Sinha, "Practical, Real-time, Full Duplex Wireless", *Proceeding of the ACM Mobicom*, Sept. 2011.
- [17] A. Sabharwal et al, "In-Band Full-Duplex Wireless: Challenges and Opportunities", *IEEE Journal on Selected Areas in Communications*, Vol. 32, No. 9, pp. 1637-1652, Sept. 2014, doi: 10.1109/JSAC.2014.2330193.
- [18] Pramono, Subuh Basuki, S. Hidayat, Sidiq Syamsul, "A compact design eight element multiple input multiple output millimeter-wave antenna", *Journal of Engineering Science and Technology*, 14, 265-278, 2019.

Creative Commons Attribution License 4.0 (Attribution 4.0 International, CC BY 4.0)

This article is published under the terms of the Creative Commons Attribution License 4.0
https://creativecommons.org/licenses/by/4.0/deed.en_US