

Performance evaluation of MC-CDMA and DS-CDMA schemes in satellite communications based on VSAT networks

¹Mohammed EL JOURMI, ²Hassan EL GHAZI, ¹Abdellatif BENNIS, ³Hassan OUAHMANE

¹Physics Department, Hassan II University, FSBM, Casablanca, Morocco

²Telecommunications Department, INPT, Rabat, Morocco

³Networks and Telecommunications Department, ENSA, El jadida, Morocco

Abstract: - The purpose of this paper is to model and evaluate the performance of a satellite communication system based on VSAT networks. In this study, the envisaged system adopts the Direct Sequence Code Division Multiple Access (DS-CDMA) scheme and Multi-Carrier Code Division Multiple Access (MC-CDMA). To improve the performance of the modeled system, and get a low bit error rate, we proposed the use of Forward Error Correction (FEC). In this paper, the performances of the satellite communication system based on VSAT network have been examined over AWGN channel. The simulation results are obtained for uncoded and coded system in the uplink case. The performance of the system is given in terms of Bit Error Rate (BER). The results analysis shows that the coded system performance is better compared to uncoded system performance. Under AWGN channel, particularly in uplink case, the DS-CDMA scheme works better than MC-CDMA in the satellite applications based on VSAT networks.

Key-Words: - VSAT Network, MC-CDMA, DS-CDMA, Convolutional Code, Uplink, Ku band.

1 Introduction

Satellite communications are the outcome of research in the area of communications and space technologies whose objective is to achieve ever increasing ranges and capacities with the lowest possible costs. Satellites are used extensively for a variety of communication applications and provide an essential ingredient to many businesses and governments worldwide.

The ground segment is that half of a satellite communication system which, quite naturally, resides on the ground. The ground segments of satellite communication systems employ a variety of node designs and network configurations in order to provide and manage services delivered to end users. In this work, the ground segment is designed to fit in the description of a Very Small Aperture Terminal (VSAT), which requires antenna dimensions less than 2.4 m in diameter [1].

The objective of this paper is to design a new satellite ground segment component for use in

telecommunications and evaluate its performance. The envisaged system adopts Direct Sequence CDMA and Multi-Carrier CDMA techniques over AWGN channel. To reduce signal errors introduced by the effect of the transmission channel, we adopted the channel coding system and specifically convolutional coding to correct errors and improve the performance of the proposed system.

In the framework of this paper, the envisaged system uses a geostationary satellite and the variations of Carrier-to-noise ratio (C/N) are dominated by atmospheric attenuation and free space path loss between the satellite and earth station. The High Power Amplifier (HPA) of Rapp's model which is based on a Solide State Power Amplifier (SSPA) is used to be able to transmit signals through great distance. The low noise amplifier (LNA) is used to amplify very weak signals captured by an antenna.

In this study, each VSAT uses a different PN sequence and each user associated to an earth station uses the Walsh codes to generate a spread signal.

The interference among the users is eliminated in AWGN channel, because the Walsh codes are orthogonal. Therefore, the inter-VSAT interference will be present because the PN sequences are not completely orthogonal.

This paper is organized as follows. In Section 2 the VSAT Network are briefly described with its two main configurations. The principles of DS-CDMA and MC-CDMA schemes are presented in Section 3. Section 4 shows the principle of convolutional coding. Characteristics of the HPA which is used in this study are illustrated in Section 5. In section 6 the link budget and simulation model are presented. Simulation results are presented in Section 7, and conclusions are drawn in Section 8.

2 VSAT Network

Traditionally, satellite dishes measured over 5 meters in diameter, were accompanied by complex electronic equipment, cost a small fortune and were used only by large telecommunications companies. With technological advancements in the satellite industry, it became possible to use smaller and cheaper dishes, which were named VSATs. VSATs are a relatively new phenomenon and have been around for about 25 years now. VSATs are parabolic dishes together with electronic equipment, used to transmit and receive information, in the form of voice, video or data via a satellite in space. Because they rely on the satellite in space to make the connection among two or more locations, VSAT systems bypass the terrestrial telecommunications infrastructure to provide direct connection to the international telecommunications network and to the Internet. They offer the ability to connect urban and remote areas without incurring huge upfront capital investments, and can claim the additional advantage of very fast turn-around times for installation.

The VSAT network can be physically configured in various ways called network topologies and there are two main network topologies:

2.1 Meshed configuration

In this network topology, shown in figure 1, VSAT terminals have the ability to communicate directly with one another without going through a central Hub. This topology requires relatively larger and more sophisticated VSAT terminals and indoor equipment which increases the start up costs. However, it is ideal for real time communications, such as telephony, among two or more locations in the same network [9][13].

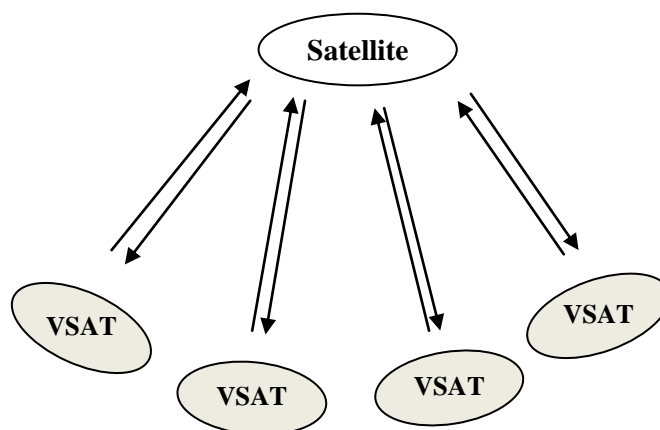

Fig. 1 Meshed topology of VSAT Network

2.2 Star configuration

This is similar to a wheel's hub and spokes with several VSAT stations communicating through a central facility (the Hub) which regulates and controls communications. This is the more common network topology in use and is shown in Figure 2. The advantage of this topology is that the individual VSAT terminals can be kept relatively small (leading to lower start up costs) provided that a large dish (typically over 5 meters) is used at the Hub [14][17].

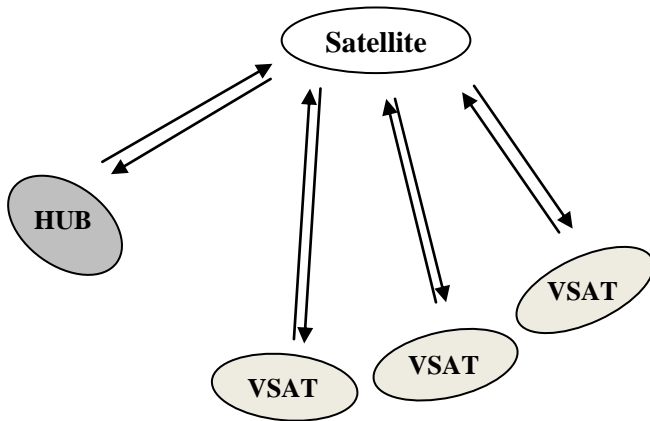

Fig. 2 Star topology of VSAT Network

In conclusion, star configuration is imposed by power requirements resulting from the reduced size and hence the low cost of the VSAT earth station in conjunction with power limitation of the satellite. Meshed configuration is considered whenever such limitations do not hold, or are unacceptable. Meshed networks have the advantage of a reduced propagation delay (single hop delay is 0.25 sec instead of 0.5 sec for double hop) which is especially of interest for telephone service [12].

3 DS-CDMA and MC-CDMA schemes

The Code Division Multiple Access (CDMA) is a multiple access scheme where several users share the same physical medium, that is, the same frequency band at the same time. In an ideal case, the signals of the individual users are orthogonal and the information can be recovered without interference from other users. Even though this is only approximately the case, the concept of orthogonality is quite important to understand why CDMA works. It is due to the fact that pseudorandom sequences are approximately orthogonal to each other or, in other words, they show good correlation properties. CDMA is based on spread spectrum, that is, the spectral band is spread by multiplying the signal with such a pseudorandom sequence [4].

In this section we briefly describe the principles of both multiple access techniques “Direct Sequence CDMA” and “Multi-carrier CDMA”.

3.1 DS-CDMA System

This sub-section explains the basic principles of operation in a DS-CDMA scheme. The block diagram of DS-CDMA system transmitting over a Gaussian channel is shown in Figure 3.

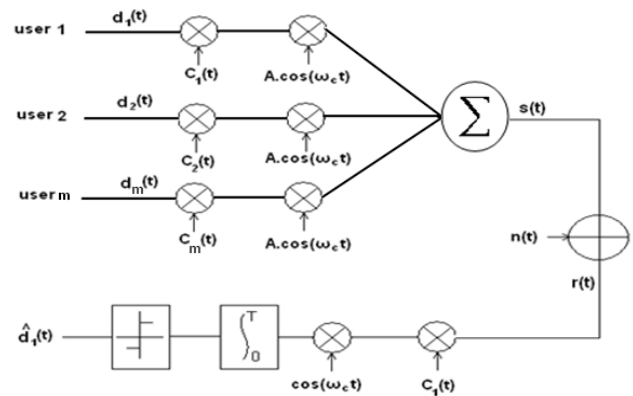

Fig. 3 Block diagram of DS-CDMA system transmitting over a Gaussian channel

This system supports M users, each transmitting its own information. The users are identified by $m = 1, 2, \dots, M$. The modulation scheme used is Binary Phase Shift Keying (BPSK). The noise signal $n(t)$ is added to the received signal. Each user’s data signal is denoted by $d_m(t)$, and each user is assigned a unique pseudo-random code also known as a spreading code denoted by $c_m(t)$. Each spreading code consists of Q pulses, commonly known as chips.

In this paper, the wanted signal is the signal of user $M = 1$ and all the other $(M - 1)$, signals are considered to be interfering signals.[2]-[3]-[4].

3.1.1 Transmitter model

Transmitted signal $S(t)$ corresponding to the l th data bit of the m th user is defined by:

$$S(t) = \sqrt{\frac{2P_{\alpha,m}}{N}} \sum_{v=0}^{S-1} \sum_{n=0}^{N-1} W_{\alpha,m}[n] b_{\alpha,m}[1] \cos(2\pi f_c t) C_{\alpha}[v] U_{T_b}(t - IT_b) \quad (1)$$

Where $P_{\alpha,m}$ is the power of data bit, $U_{T_b}(t - IT_b)$ is the rectangular pulse defined in the $[0, T_b]$. Every user has a spreading code $W_{\alpha,m}[n]$ with $n = 0, 1, \dots, N - 1$ and N is the length of the sequence chip. α denote the number of VSATs with $\alpha = 1, 2, \dots, K$ and K is the maximum number of VSATs. The same signature sequence chip is used to modulate each of the N carriers of the m th user. The maximum number of users in the system is M . Every VSAT has a signature $C_{\alpha}[v]$ with $v = 0, 1, \dots, S - 1$ and S is the length of the spreading code.

3.1.2 Receiver model

The receiver signal of M active users in the VSAT-MC-CDMA system can be written as:

$$R(t) = \sum_{\alpha=1}^K \sum_{m=0}^{S-1} \sum_{n=0}^{N-1} \sqrt{\frac{2P_{\alpha,m}}{N}} W_{\alpha,m}[n] b_{\alpha,m}[1] \cos(2\pi f_c t) C_{\alpha}[v] U_{T_b}(t - IT_b) + n(t) + \xi(t) \quad (2)$$

Where $n(t)$ is the additive white Gaussian noise (AWGN) with double sided power spectral density of $N_0/2$ and $\xi(t)$ is the inter-VSAT interference.

3.2 MC-CDMA System

Multi-carrier CDMA system is based on a combination of the CDMA scheme and orthogonal frequency division multiplexing (OFDM) signaling. OFDM is a digital multicarrier transmission technique that distributes the digitally encoded symbols over several subcarrier frequencies in order to reduce the symbol clock rate to achieve the good robustness. Even though the spectra of the individual subcarriers overlap, the information can be completely recovered without any interference from other subcarriers. This may be surprising, but from a

mathematical point of view, this is a consequence of the orthogonality of the base functions of the Fourier series [4].

MC-CDMA transmitter spreads the original signal using a given spreading code in the frequency domain. In other words, a fraction of the symbol corresponding to a chip of the spreading code is transmitted through a different subcarrier.

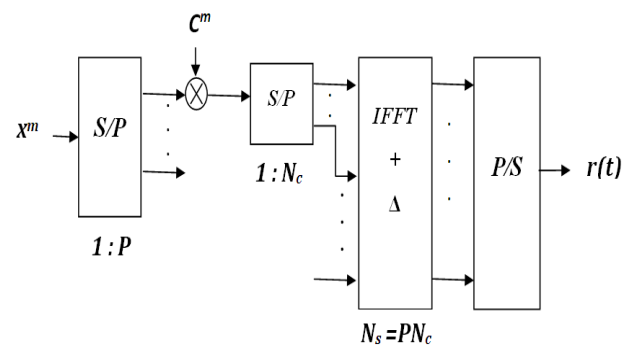

Fig. 4 MC-CDMA Transmitter

The figure 4 shows the MC-CDMA transmitter for the m th user. The input information sequence is first converted into P parallel data sequences, and then each Serial/Parallel converter output is multiplied with the spreading code with length L_c . All the data in total $N = P \times L_c$ (corresponding to the total number of subcarriers) are modulated in baseband by the inverse Fast Fourier transform (IFFT) and converted back into serial data. The guard interval Δ is inserted between symbols to avoid intersymbol interference, and finally the signal is transmitted.

Figure 5 shows the MC-CDMA receiver. It requires coherent detection for successful despreading operation and this causes the structure of MC-CDMA receiver to be very complicated. In figure, the k -subcarrier components ($k=1, 2, \dots, L_c$) corresponding to the received data y^m is first coherently detected with FFT and then multiplied with the gain G to combine the energy of the received signal scattered in the frequency domain [7]-[8].

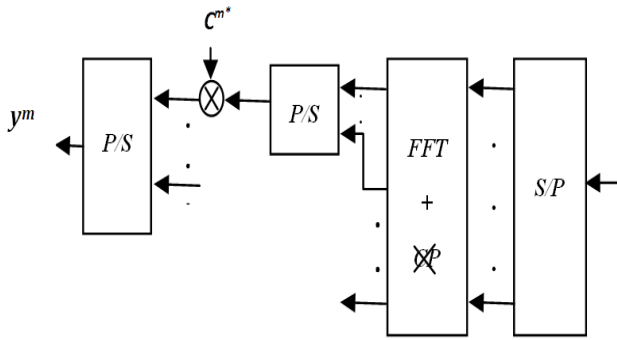

Fig. 5 MC-CDMA Receiver

3.2.1 Transmitter model

Transmitted signal $S(t)$ corresponding to the l th data bit of the m th user is defined by:

$$S(t) = \sqrt{\frac{2P_{\alpha,m}}{N}} \sum_{v=0}^{S-1} \sum_{n=0}^{N-1} W_{\alpha,m}[n] b_{\alpha,m}[l] \cos\left(2\pi\left(f_c + \frac{n}{T_b}\right)t\right) C_{\alpha}[v] U_{T_b}(t - lT_b) \quad (3)$$

Where $P_{\alpha,m}$ is the power of data bit, $U_{T_b}(t - lT_b)$ is the rectangular pulse defined in the $[0, T_b]$. Every user has a spreading code $W_{\alpha,m}[n]$ with $n = 0, 1, \dots, N - 1$ and N is the length of the sequence chip. The same signature sequence chip is used to modulate each of the N carriers of the m th user. The maximum number of users in the system is M . Every VSAT has a signature $C_{\alpha}[v]$ with $v = 0, 1, \dots, S - 1$ and S is the length of the spreading code. α denote the number of VSATs with $\alpha = 1, 2, \dots, K$ and K is the maximum number of VSATs.

3.2.2 Receiver model

The receiver signal of M active users in the VSAT-MC-CDMA system can be written as:

$$R(t) = \sum_{\alpha=1}^K \sum_{v=0}^{S-1} \sum_{m=0}^{M-1} \sum_{n=0}^{N-1} \sqrt{\frac{2P_{\alpha,m}}{N}} W_{\alpha,m}[n] b_{\alpha,m}[l] \cos\left(2\pi\left(f_c + \frac{n}{T_b}\right)t\right) C_{\alpha}[v] U_{T_b}(t - lT_b) + n(t) + \xi(t) \quad (4)$$

Where $n(t)$ is the additive white Gaussian noise (AWGN) with double sided power spectral density of $N_0/2$ and $\xi(t)$ is the inter-VSAT interference.

4 Convolutional codes

Channel coding is a common strategy to make digital transmission more reliable, or, equivalently, to achieve the same required reliability for a given data rate at a lower power level at the receiver. This gain in power efficiency is called coding gain. For wireless communication systems, channel coding is often indispensable. This section gives a brief overview over the strategy of the channel coding "convolutional codes" that is commonly applied in OFDM and CDMA systems.

A convolutional encoder generates code symbols for transmission utilizing a sequential finite-state machine driven by the information sequence. Decoding these codes then amounts to sequentially observing a corrupted version of the output of this system and attempting to infer the input sequence. From a formal perspective, there is no need to divide the message into segments of some specific length.

Figure 6 illustrates one of the simplest nontrivial convolutional encoders. It is implemented by a shift register of memory (number of delay elements) $m = 2$ and three summers \oplus over Galois field $GF(2)$. The rate of the code is $r = 1/2$. The information sequence $\dots \beta_0, \beta_1, \dots, \beta_n, \dots, \beta_n \in \{0, 1\}$, is the input sequence of the encoder. The encoder is a finite-state machine that can be described in terms of its state transition diagram. This is shown in Figure 7, where the nodes refer to the contents of the register just before the next input bit arrives. The encoder inputs $\dots \beta_0, \beta_1, \dots, \beta_n, \dots$, and outputs $\dots \alpha_0, \alpha_1, \dots, \alpha_n, \dots, \beta_n, \alpha_n \in \{0, 1\}$ (2 output symbols per input bit for the rate $r = 1/2$ encoder) are shown as labels on the transition branches[6].

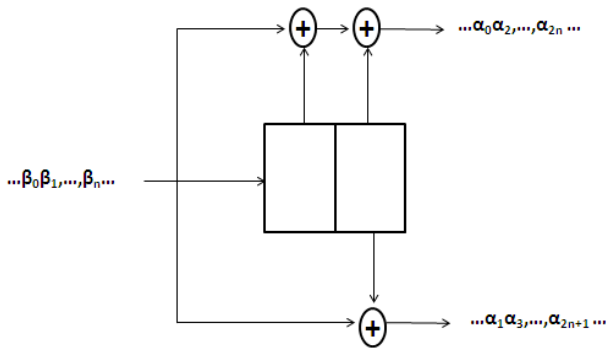

Fig. 6 A rate $r = 1/2$ memory $m = 2$ convolutional encoder

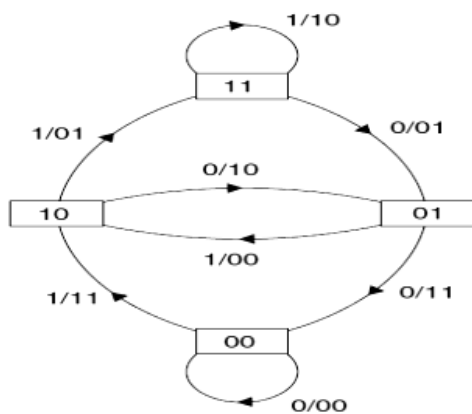

Fig. 7 The state-transition diagram for the encoder in Fig. 6

Decoding of convolutional codes is a more difficult problem than encoding. The function of a convolutional decoder is estimating the encoded input information using a method that results in the minimum possible number of errors. Unlike a block code, a convolutional code is a finite state machine. Therefore, the output decoder is a “maximum likelihood estimator” and optimum decoding is done by searching through the trellis for the most probable sequence. Depending on whether hard decision or soft decision decoding is used, either the Hamming or Euclidian metric is used, respectively.

Convolutional coding can be decoded with several different algorithms. The Viterbi algorithm is the most commonly used [5], and for this reason we adopted the Viterbi decoder to decode the data encoded with Convolutional encoder.

5 High Power Amplifier Model

Power amplifiers are typically the most power-hungry components of RF transceivers. The design of PAs, especially for linear, low-voltage operations, remains a difficult problem defying an elegant solution. Two type’s amplifiers are mostly used in satellite communication: Traveling Wave Tube Amplifier (TWTA) and Solid State Power Amplifier (SSPA). TWTA is mostly used for high power satellite transmitters while SSPA is used in many other applications including small size transmitters as VSAT.

The complex output of RF with non-linear distortion can be expressed as:

$$z(t) = f[u_y(t)]e^{-j[\alpha_y(t)+\phi(u_y(t))]} \tag{5}$$

Where $u_y(t)$ and $\alpha_y(t)$ are the modulus and phase of the input signal. The measured AM/AM and AM/PM for SSPA is well presented by Rapp’s model [16] [15] as:

$$f[u_y] = \frac{u_y}{[1 + (u_y / A_{max})^{2p}]^{1/2p}}$$

$$\phi[u_y] = 0 \tag{6}$$

Here A_{max} is the maximum output amplitude and the parameter p controls the smoothness of the transition from the linear region to the limiting region [15]. For these types of amplifiers we can notice that the SSPA adds no phase distortion.

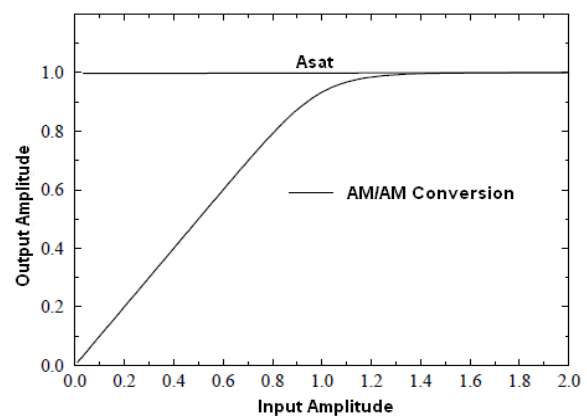

Fig.8 The SSPA characteristics : Normalized AM/AM conversion ($A_{sat}=1$)

6 Simulation model and System Specification

In this section we present the description of the simulation model and we illustrate the main characteristics of our proposed communication system. The figure 9 illustrates the overall simulation model. As we can see the binary input signal to the system is converted to symbol stream after passing through the encoder. The frequency domain spreading is done by using signature sequence of length 32 in the CDMA transmitter [10].

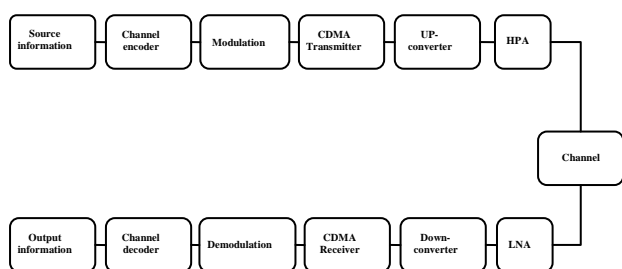

Fig 9. Overall Simulation Block Diagram

The up-converter is capable of outputting its carrier at the desired RF frequency. Signal is amplified with HPA before being transmitted through the transmission channel. LNA amplifies very weak signals captured by the VSAT antenna. Down-converter converts the desired signal band to a convenient IF frequency for digitization. Despreading in the CDMA receiver, demodulation is done before passing through the decoder. The original binary data is recovered after passing through the decoder. In the VSAT MC-CDMA system we considered that the number of subcarriers is equal to the length of the signature sequence. The simulation parameters chosen for this study are the same parameters used in [11]. Thus the parameters that we used are as follows:

Table 1: General information

Satellite orbit radius	42242 km
Earth radius	6370 km
Distance from the VSAT to satellite	38054 km
Free space loss	206.1 dB
Speed of light, c	3.108 ms-1
Boltzmann's constant	-228.6 dBJK-1 (=1.38 × 10 ⁻²³ J/K)

Table 2: VSAT Parameters

up-link frequency F_u	14.25 GHz
VSAT HPA output power P_{TxVSAT}	1 W
Antenna gain	42.84 dBi
Antenna diameter	1.2 m
EIRP	42.84 dBW
VSAT latitude	45.5° N
VSAT longitude	9.5° E
Elevation angle	37.56°
Azimuth angle	183.5°

Table 3: Satellite Parameters

Satellite figure of merit $(G/T)_{SL}$	1 dB/K
satellite receiver effective input noise temperature	500 K
Satellite antenna noise temperature	290 K
uplink system noise temperature	790 K
Power Flux density ϕ	-119.22 dBW/m ²
Transponder bandwidth	54 MHz
Satellite antenna gain	31 dBi
Sub-satellite point longitude	7° E
C/N ₀ in up-link	66.34 dBHz

7 Simulation and comparison

In this section the simulation results are presented to examine and discuss the bit error rate performance of VSAT MC-CDMA and VSAT DS-CDMA receivers over AWGN channel with multiple users. The number of subcarriers used in the simulation system is 32, and this means the case of 32 active users corresponds to the fully loaded case. In our simulations the length of Walsh codes and PN sequences is fixed at 32, the output of S/P (serial to parallel) converter is fixed at 16 and the duration of the guard interval is $0,1953 \mu\text{s}$ (20% of symbol duration).

In this study, the maximum number of earth stations is fixed at eight. Indeed, 8 users are distributed over two VSATs, 16 users are distributed over four VSATs and 32 users are distributed over eight earth stations. However, all users in the VSAT network are uniformly distributed between the ground stations.

7.1 Performance of uncoded systems

At first, we focus on the evaluation of system performance without introducing channel coding. Figure 9 shows the performance curves of uncoded VSAT MC-CDMA and VSAT DS-CDMA systems.

In the figure 9 we can see the system performance for a variable number of users ($m = 1, 8, 16$ and 32). We can notice that the inter-VSAT interference (interference between VSATs stations) is the major source of performance deterioration of the system, because the interference between users is removed by the orthogonality of the Walsh codes. It is also noted that the increased number of users implicate the increased number of VSATs, and that results a penalty on system performance because of inter-VSAT interference.

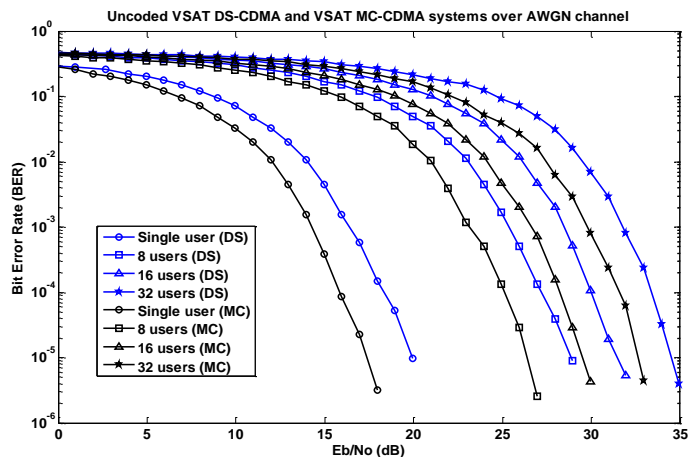

Fig. 9 Performance of uncoded VSAT DS-CDMA and VSAT MC-CDMA systems over AWGN channel

We analyze the results of the figure 9, we note that for single user the BER performance achieves up to 10^{-6} at $E_b/N_0=18$ dB for VSAT MC-CDMA system and at E_b/N_0 beyond 20 dB for VSAT DS-CDMA system. The comparison between the performance of DS-CDMA and MC-CDMA schemes in the VSAT Network shows that the use of MC-CDMA in the VSAT network offer an additional gain of 2.5 dB for a bit error rate of 10^{-5} .

For full loading case, we can see that the performance of both systems is decreased by the influence of the inter-VSAT interference which became present by the increasing of the number of earth stations in the network. Always in the full loading of the VSAT network, it is observed that for a bit error rate of 10^{-5} the MC-CDMA scheme provides a supplementary gain of approximately 2 dB compared with DS-CDMA technique (for a similar number of users).

We can also note that for both systems (VSAT MC-CDMA and VSAT DS-CDMA) the performance is not very good without introducing the channel coding, and it degrades rapidly as the total number of users increase. For this reason we have introduced the convolutional code mechanism to protect the transmitted signal against the errors due to the channel imperfection (see the next subsection).

7.2 Performance of coded systems

In this sub-section we evaluated the performance of VSAT MC-CDMA and VSAT DS-CDMA systems with convolutional code. The simulation results of the system using convolutional code over AWGN channel are shown in figure 10. The decoder type used for convolutional coding is the Viterbi decoder with a code rate of 1/3.

From figure 10, we can note that the channel coding presents an effective way to decrease the number of errors in the received signals. Consequently the VSAT MC-CDMA and VSAT DS-CDMA systems with convolutional code can achieve much better performance compared to uncoded systems.

As we can see, for single user the BER performance achieves up to 10^{-7} at $E_b/N_0 = 11$ dB for VSAT MC-CDMA system. But, for VSAT DS-CDMA system the BER performance achieves up to 10^{-6} at E_b/N_0 beyond 12 dB. In the figure we can observe that the performance difference between MC-CDMA and DS-CDMA in the VSAT network is 1.6 dB at a bit error rate beyond $2.5 \cdot 10^{-6}$.

For 32 users active in the network we observe that the performance difference between the performance curves of the both schemes in the VSAT network at a bit error rate beyond 10^{-5} is 1.5 dB.

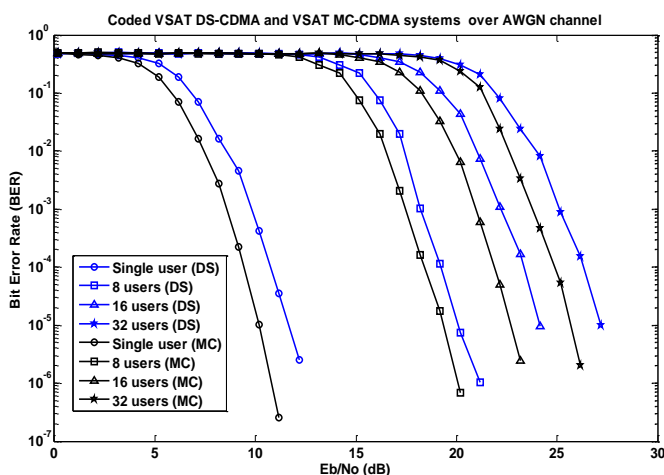

Fig. 10 Performance of coded VSAT DS-CDMA and VSAT MC-CDMA systems over AWGN channel

We can also note that, for coded VSAT MC-CDMA system we obtained a coding gain of 7 dB compared to uncoded VSAT MC-CDMA system. For VSAT DS-CDMA the coding gain obtained is approximately 8 dB. We finally note that the performance of VSAT MC-CDMA system is always better than the DS-CDMA system and that in both cases "uncoded and coded with convolutional code".

From the performance curves shown in figures fig.9 and fig.10, it is obvious that the system which adopts the MC-CDMA technique achieves lower bit error rate than the system which uses the DS-CDMA scheme. Now it is easy to note that the performance improvement is more pronounced for VSAT MC-CDMA system than VSAT DS-CDMA system. It is concluded that MC-CDMA scheme is more suitable for VSAT network applications, as compared to DS-CDMA.

8 Conclusion

In this paper, a satellite communication system, which uses VSATs as the ground terminals and CDMA scheme as a multiple access technique, was examined in the uncoded and coded conditions. To get the lower bit error rate, the most common type of channel coding method "convolutional code" is used to reduce the errors rate in the received signals. By comprehensive computer simulation, it is shown that in uplink case of communication systems based on VSAT network the MC-CDMA scheme can provides a marked performance improvement than DS-CDMA technique and that is showed in coded and uncoded situations.

At last of this work, it is concluded that MC-CDMA has much better performance than DS-CDMA in the VSAT network. Thus, MC-CDMA is more suitable than DS-CDMA for satellite communication system based on VSAT Network.

References

- [1] Jonathon, Y., C. Cheah, M.E. Davis, "Tone Interference in VSAT Sptectrum," IEEE Transactions on Communications, Vol. 45, No. 9, pp. 1035-1038, September 1997.
- [2] S. G. Glisic and P. A. Lepp^ˆannen, Wireless Communications TDMA versus CDMA. Kluwer Academic Publishers,1997.
- [3] R. Prasad, CDMA for Wireless Personal Communications. Artech House, Inc., 1996.
- [4] K. Fazel and S. Kaiser, Multi-Carrier and Spread Spectrum Systems. Chichester: John Wiley & Sons, 2003.
- [5] Rappaport, T.S., Wireless Communications, 2nd ed., Prentice Hall, 2002.
- [6] Kamil,Sh. Zigangirov. Theory of Code Division Multiple Access Communication.Institute of Electrical and Electronics Engineers,2004.
- [7] H. E. Ghazi, "Allocation Algorithm for Optimizing MC-CDMA Over Correlated Channel"accepted by WSEAS Trans. On commun.2010.
- [8] Q. Shi and M. Latva-Aho, "Performance analysis of MC-CDMA in Rayleigh fading channels with correlated envelopes and phases," IEE Proc. Commun., vol. 150, pp. 214–220, June 2003.
- [9] Maral, G. 1996. VSAT Networks. New York: John Wiley & Sons Ltd.
- [10] M. El jourmi, "Performance analysis of channel coding in satellite communicationbased on VSAT Network and MC-CDMA scheme" WSEAS Trans. on commun., issue 5, vol 12, May 2013.
- [11] M. El jourmi, "Performance Enhancement of VSAT MC-CDMA System Using Channel Coding Techniques and Predistortion over Rayleigh Channel" WSEAS Trans. on commun., Volume 13, 2014.
- [12] Elbert, B.R., The Satellite Communication Ground Segment and Earth Station Handbook, Artech House, 2000.
- [13] Elbert, B.R., Introduction to Satellite Communication 3rd , Artech House, 2008.
- [14] Moheb, H., C. Robinson, J. Kijeski, "Design and Development of Co-Polarized Ku-band Ground Terminal System for VSAT Application," IEEE Publications 0-7803-5639-X/99, pp. 2158-2161, 1999.
- [15] R. zayani, S. Zid, R. Bouallegue, « Simulateur des non-lin^ˆarit^ˆes HPA sur un syst^ˆeme OFDM » OHD Conference, septembre 2005.
- [16] A. N. D'Andrea, V. Lottici and R. Reggiannin, «Nonlinear Predistortion of OFDM Signals over Frequency-Selective Fading Channels», IEEE Transactions on Communications. Vol. 49. N^o 5. pp. 837-843. 2001.
- [17] Maral, G., Bousquet, M., "Satellite Communications Systems: Systems, Techniques And Technology, 5th Edition", Chichester : Wiley , cop. 2009.