

Using Piezoelectric Elements to Convert Bio-Mechanical Pulsations into Electrical Energy for Energy Harvesting

ISAO NAKANISHI, HIROYUKI NAKAMURA, MASAYA JYOUKI, YUUMA HATAMOTO
Tottori University,
4-101 Koyama-minami, Tottori-shi, 680-8552,
JAPAN

Abstract: On the Internet of Things (IoT) where all electronic devices are connected to the internet, a secure power supply is necessary. Energy harvesting technology is attracting attention as "enabling technology" that expands the use and opportunities of IoT utilization. This technology harvests energy that dissipates around us, in the form of electromagnetic waves, heat, vibration, etc. and converts it into easy-to-use electric energy. Alternating current signals can be extracted from bio-mechanical pulsations using skin-attached piezoelectric elements with a protrusion, as we reported previously. However, we found that the maximum voltage of the extracted signal was unstable and low. This study demonstrates that piezoelectric elements can be stacked to stabilize and increase the maximum voltage, and that the extracted signal can be used to charge a capacitor, after rectification using a voltage-doubler rectifier circuit with Schottky barrier diodes.

Key-Words: Energy Harvesting, Piezoelectric Element, Pulsation, Protrusion, Schottky Barrier Diode, Voltage Doubler Rectifier Circuit.

Received: September 14, 2023. Revised: August 12, 2024. Accepted: September 11, 2024. Published: October 9, 2024.

1 Introduction

In recent years, smartphones, tablet terminals, and even sensors and home appliances such as televisions and audio equipment have become connected to the Internet. We are now living in an Internet of Things (IoT) world in which many kinds of electronic devices are connected through the Internet.

However, connecting all these electronic devices to the internet requires a corresponding power supply. Primary batteries cause disposal-related environmental problems. Energy harvesting is an alternative that collects and utilizes the unused energy in our surroundings, [1]. Photovoltaic-power generation is a well-known energy-harvesting technology. Floor power generation is also a form of energy harvesting. Piezoelectric elements are embedded in the floor, and electricity is generated when people walk on it. There are other methods that use heat, vibration, moving, radio waves, pressure differences, bioderived materials, etc.

This study focuses on energy harvesting using bio-mechanical signals, [2], [3], [4], [5]. In particular, various attempts have been made to convert human body fluctuations into electrical energy using piezoelectric elements, [6], [7], [8], [9]. However, fluctuations based on human actions generate electricity only when an action is performed. On the other hand, the life-long heartbeat could provide a semipermanent energy source; however, it requires surgery. If the heart's motion would be

sensed outside the body, a semi-permanent energy source could be obtained.

One possible way is to use piezoelectric elements to convert the skin fluctuations caused by the pulsating cardiovascular system to alternating current (AC) signals, which are then rectified, and used to charge a capacitor. Research from this perspective has largely focused on device manufacturing, [10]. Its effectiveness has only been verified using artificial pressure and not in the human body.

In our previous study, [11], a piezoelectric element was attached to the human body, and it was confirmed that the pulsations could be converted to AC signals. However, the peak voltage was approximately 200 mV. To charge the capacitor, it is necessary to rectify the AC signal using a diode-based rectifier circuit, with a diode threshold voltage of approximately 600 mV; therefore, a higher maximum voltage is required.

We attempt to increase the output voltage by stacking the piezoelectric elements. Furthermore, by introducing the lower threshold-voltage diode and rectifier circuit, the capacitor can be charged.

2 Pulsation-Energy Extraction Using Piezoelectric Elements

The purpose of this study is to convert bio-mechanical pulsation energy into electrical energy using piezoelectric elements. The piezoelectric element is placed in close contact with the skin; the mechanical pressure is converted into an AC signal rectified into

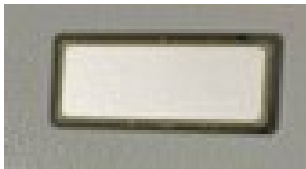

Fig01: Piezoelectric element used

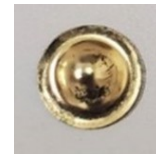

Fig04: Protrusion used



Fig02: Piezoelectric element taped to the wrist

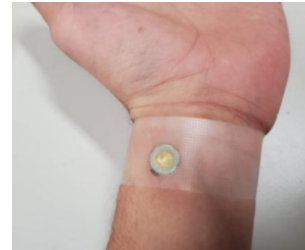

Fig05: The protrusion taped to the wrist, [11]

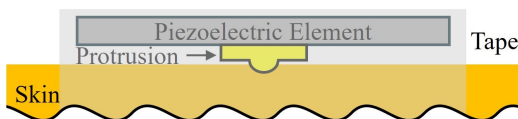

Fig0 3: "Relationship between the piezoelectric element and the skin

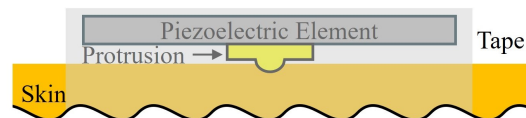

Fig0 6: "The protrusion and the piezoelectric element on the skin viewed from the side

a positive-only signal by a rectifier circuit, and the rectified signal charges a capacitor. Because this technology generates electrical energy, no additional power source is required during the entire process.

2.1 Previous Work, [11]

A piezoelectric element is a passive device based on the piezoelectric effect which generates a voltage when pressure is applied. The piezoelectric elements used in this study are shown in Fig. 1 (K2512BS1 of the THRIVE KINEZ series).

The piezoelectric component and electrode are made of flexible materials and can be placed close to the skin. The piezoelectric element outputs an electric voltage proportional to the change in applied pressure; therefore, no voltage is generated under constant pressure. Because the piezoelectric element in Fig. 1 had no pre-attached lead wires, they were attached by soldering, and the entire device was covered with an insulation tape. The device was

then fixed to the wrist with medical tape (hereinafter referred to as "tape"), at the point where the radial artery passes close to the skin. Fig. 2 shows the location, and Fig. 3 shows the relationship between the element and the skin.

The output signal from the piezoelectric element was observed using an oscilloscope. Consequently, an output signal, corresponding to the pulsations, was observed; however, the maximum voltage was approximately 40 mV. The reason for this was believed to be that the pulsations did not reach the piezoelectric element sufficiently. Therefore, a protrusion (Fig. 4) was inserted between the skin and piezoelectric element.

This is similar to pressing the wrist with a fingertip when examining a pulse. We used a disposable electrode for cardiac electrocardiography with the adhesive pad removed, leaving only the metallic part. If the part of the protrusion that touches the skin is sharp, it is painful; therefore, a rounded electrode was used. (This is not mandatory; alternates can be used.)

Fig. 5 illustrates the placement and fixing (by tape) of the convex portion of the protrusion against the skin. They were then taped over the top. Fig. 6 shows the side view.

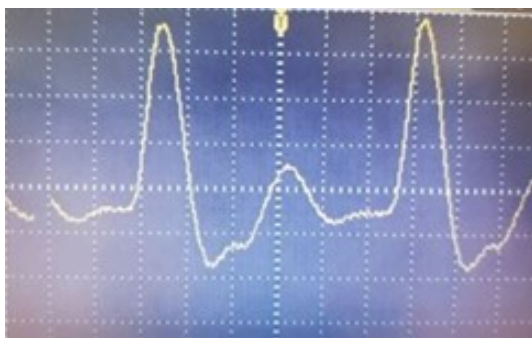

Fig0 7: An example of the extracted waveform obtained by inserting a protrusion (20 mV/div, 322ms/div), [11]

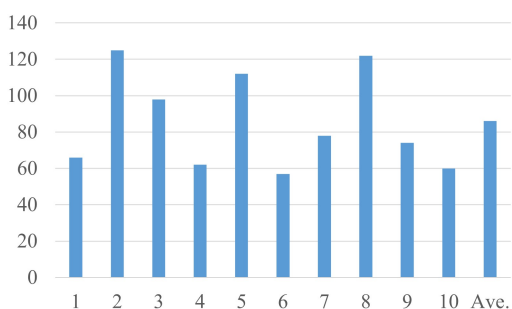

Fig0 8: Maximum voltage (mV) in 10 measurements

The waveform shown in Fig. 7 was obtained when the output signal was observed using an oscilloscope. The period of this signal was approximately 0.7 s, which is almost the same as that of a heartbeat; therefore, the obtained signal was judged to be from pulsation. The maximum voltage of the extracted signal increases to approximately 80 mV.

2.2 Stabilization of Output Signal

The measurements were repeated 10 times. The tape used to fix the protrusion and piezoelectric element was changed for each measurement. The maximum values of the obtained voltage signals, and their average value, are shown in Fig. 8. Although the pulsations could be transduced, there was a large variation in the measurements, as shown in the figure, and a stable output could not be obtained.

The cause of this variation was attributed to the difficulty in maintaining a constant force while fixing the tape. Fixing the protrusion and piezoelectric elements, separately, increased the variation.

Therefore, we first fixed the piezoelectric element and protrusion with insulating tape, as shown in Fig. 9, and then fixed them to the wrist with a single piece



Fig09: Piezoelectric element with protrusion fixed with insulation tape

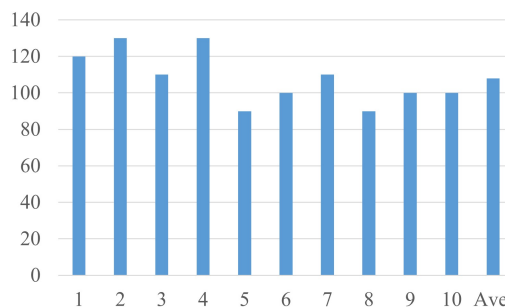

Fig0 10: Maximum voltage (mV) in 10 measurements after devising

of tape. In addition, because the force of the fixation varies with the length of the tape, the tape length was standardized to 20 cm and the wrist angle was fixed. Fig. 10 shows that the output measurement results were more uniform than those in Fig. 8.

3 Attempts to Increase Output

The piezoelectric element converts the bio-mechanical pulsation pressure signal into a voltage signal; which must pass through a diode rectifier circuit. However, the diodes have a threshold voltage (approximately 600 mV for silicon devices), even in the forward direction, and no output is generated unless the voltage exceeds this threshold. As discussed in the previous section, the output-signal voltage was approximately 100 mV and could not be rectified at this level.

However, piezoelectric elements with higher outputs were not available to us; therefore, we attempted to increase the output-signal level using multiple piezoelectric elements. The wrist area where the pulsation can be sensed is small, and even if multiple piezoelectric elements were placed side by side, none of them would detect the pulsation. Therefore, multiple piezoelectric elements were stacked on top of each other.

3.1 Two Piezoelectric Elements Stacked

As shown in Fig. 11, the two piezoelectric elements with protrusions were placed directly above each other. The piezoelectric element closest to the skin

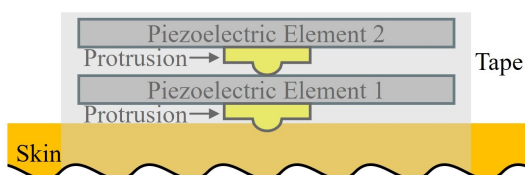

Fig0 11: Two piezoelectric elements on the skin viewed from the side

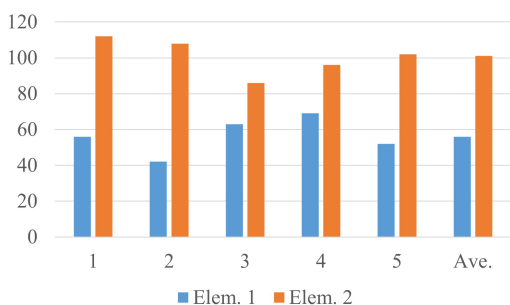

Fig0 12: Maximum voltage (mV) of two piezoelectric elements

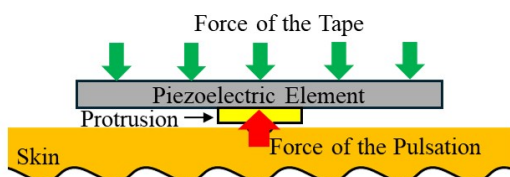

Fig0 13: Force applied to one piezoelectric element

was labeled 1, and the element on top of it was 2. The measurements were performed five times. The results are shown in Fig. 12. The piezoelectric elements were able to output average maximum voltage of 56 mV and 101 mV for piezoelectric elements 1 and 2, respectively. The average maximum voltage of Piezoelectric Element 2 was equivalent to that of a single piezoelectric element, whereas that of Piezoelectric Element 1 was approximately half of that value.

The reasons for this are discussed below: Fig. 13, Fig. 14, and Fig. 15 show the force applied to a single piezoelectric element, and the forces applied to Piezoelectric Element 2 and 1, when stacked. In these figures, the tape is omitted. In the case of Piezoelectric Element 2 in Fig. 14, the force pressing down on the skin with the tape from above and the pulsation force from below through Piezoelectric Element 1 are the same as those in the case of the

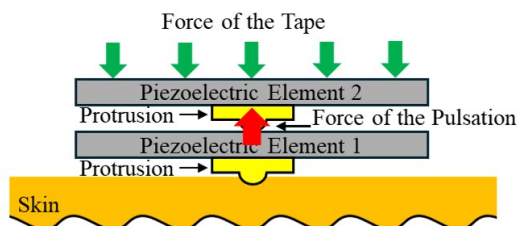

Fig0 14: Force applied to piezoelectric element 2 when two piezoelectric elements are stacked.

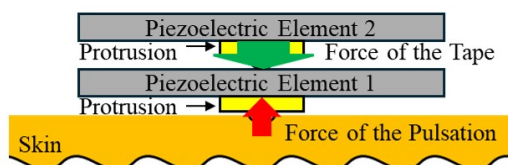

Fig0 35: Force applied to piezoelectric element 1 when two piezoelectric elements are stacked

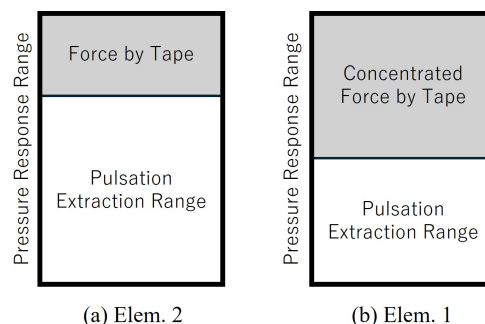

Fig0 16: Illustration of why the output voltage of Piezoelectric Element 1 reduces

single piezoelectric element in Fig. 13. This suggests that the average output value of Piezoelectric Element 2 is equivalent to that of one piezoelectric element. However, in the case of Piezoelectric Element 1 in Fig. 15, the force of the pulsation pushing up the skin is the same as that of Piezoelectric Element 2, but the force to be fixed by the tape is concentrated at one point through the protrusion of Piezoelectric Element 2; thus, a larger force is applied from the top than in the case of one piezoelectric element. The force applied by the tape is constant, and as mentioned earlier, the piezoelectric element only reduces the response range of the piezoelectric element to the pressure and does not generate voltage at constant pressures.

This is illustrated in Fig. 16. The

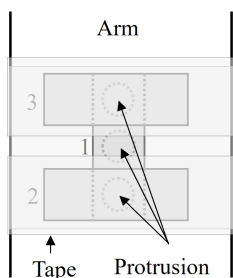

Fig0 17: Arrangement of three piezoelectric elements

pressure-response capability of both piezoelectric elements was finite and identical, as indicated by the bold boxes in the figure. The constant force required to fix them is indicated by the colored area in the figure. The force required to fix Piezoelectric Element 1 is larger than that required to fix Piezoelectric Element 2, as shown in (b). This limited the range that detected the pulsation and the output voltage was low.

3.2 Three 'Piezoelectric' Elements 'Unstacked'

As shown in the previous section, when two piezoelectric elements are stacked, and the protrusions are placed such that their positions overlap, the output voltage of one of the piezoelectric elements decreases. Therefore, we shift the positions of the protrusions.

Although the force applied to the lower piezoelectric element should strictly be the same even if the positions of the protrusions are shifted, the piezoelectric element and electrode are made of a flexible material; therefore, the constant force applied to Piezoelectric Element 1 (by the fixing tape) is distributed and weaker than when it is sandwiched between the upper and lower protrusions. In addition, even if the output values of the two piezoelectric elements are equal, their combined value does not exceed the threshold voltage of the diode.

Therefore, the number of piezoelectric elements is increased to three. Each of them are fixed individually with tape. When we tried to fix them with a single piece of tape, the pulsation did not evenly reach the three piezoelectric elements because the stacked piezoelectric elements tilted.

Fig. 17 shows the arrangement of the piezoelectric elements. Piezoelectric Element 1 was fixed with tape, and Piezoelectric Elements 2 and 3 were then taped to both ends of Piezoelectric Element 1, avoiding the protrusion at the center of Piezoelectric Element 1. A side view of their arrangement is shown in Fig. 18.

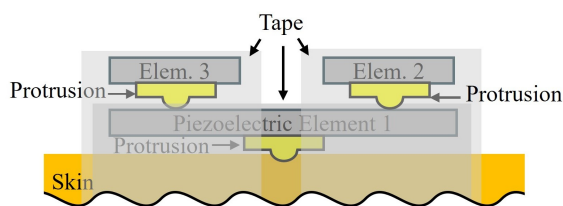

Fig018: Fixing arrangement of three piezoelectric elements

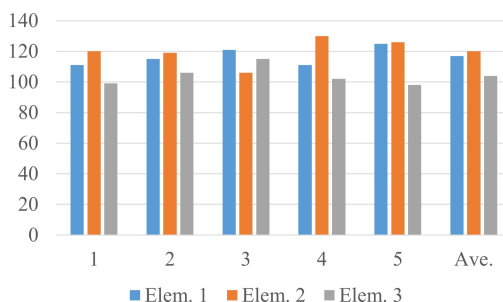

Fig019: "Maximum voltage of three piezoelectric elements

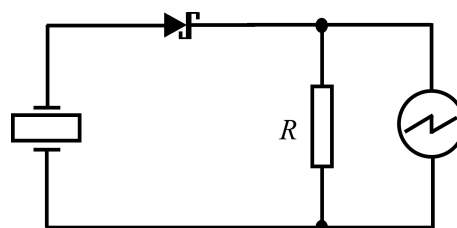

Fig0 20: "Half-wave rectification circuit using a Schottky barrier diode

The output of each of the three piezoelectric elements was measured five times. The results are presented in Fig. 19. The average maximum voltage of the three piezoelectric elements were 117 mV, 120 mV, and 131 mV for Piezoelectric Element 1, 2, and 3 respectively. The maximum voltage of each of these elements was almost equivalent to that of a single piezoelectric element, and the total output exceeded 350 mV.

4 Rectifier Circuit and Capacitor Energy Storage

Stacking the three piezoelectric elements and fixing them with tape after shifting the protrusion positions, an output signal exceeding 350 mV was obtained. Then, we attempted to rectify the signal and charge

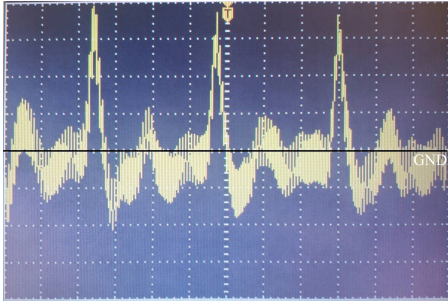

Fig021: The waveform before rectification (100 mV/div, 200 ms/div)

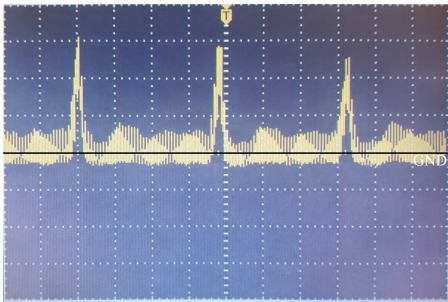

Fig0 22: The waveform after rectification (100 mV/div, 200 ms/div)

the capacitor using the rectified signal. However, a general-purpose silicon diode has a forward threshold voltage of approximately 600 mV. The maximum voltage obtained in the previous section does not exceed that value; therefore, rectification is not possible without modification.

Therefore, Schottky barrier diodes (1N5819), which typically have a low threshold voltage of 150–450 mV, were selected. As shown in Fig. 20, the rectification waveform was observed across a 1 MΩ load resistor, using an oscilloscope.

The waveforms before and after the rectification are shown in Fig. 21 and Fig. 22, respectively. It was confirmed that the rectification was achieved by using stacked three piezoelectric elements and a Schottky barrier diode.

Next, we replaced the resistor with a capacitor and verified whether the capacitor could be charged. The circuit diagram is shown in Fig. 23. An electrolytic capacitor with a 1 μF capacitance was used.

The capacitor was charged when a large pulsation occurred but was discharged before the next large pulsation occurred; as a result, electricity was not stored in the capacitor. Increasing the capacitance to 10 μF gave the same results.

The next point of interest was the negative voltage

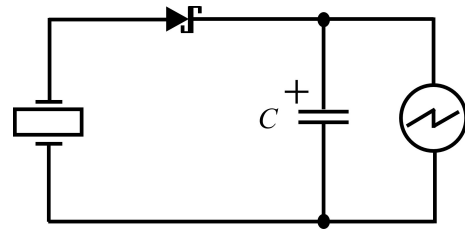

Fig. 23: Half-wave rectification circuit terminating in a single capacitor

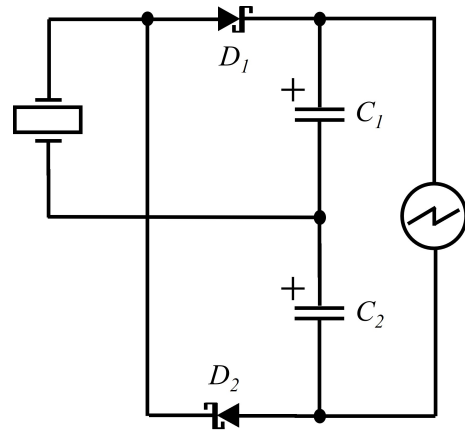

Fig. 24: Capacitor charging using a voltage-doubler rectifier circuit

generated during the discharge period. For general diodes, the reverse (leakage) current is extremely small; however, it is not negligible for Schottky barrier diodes. This was observed in Fig. 22. Therefore, it was assumed that the capacitor charged in the forward direction was discharged by the leakage current in the reverse direction.

Therefore, we used a diode-bridge (full-wave) rectifier circuit to eliminate discharge effect. However, the rectified waveforms could not be obtained because in the full-wave rectifier circuit, rectification is performed by two diodes in series (in both the forward and reverse directions) resulting in double the diode threshold voltage. The maximum voltage of the extracted signal did not exceed the threshold.

Therefore, a voltage-doubler rectifier circuit was used. The corresponding circuit diagram is shown in Fig. 24. This circuit requires only one-diode threshold voltage because it is rectified with a single diode in the forward or reverse direction.

The results are shown in Fig. 25. It was confirmed that the capacitor was gradually charged and the voltage reached approximately 6 mV.

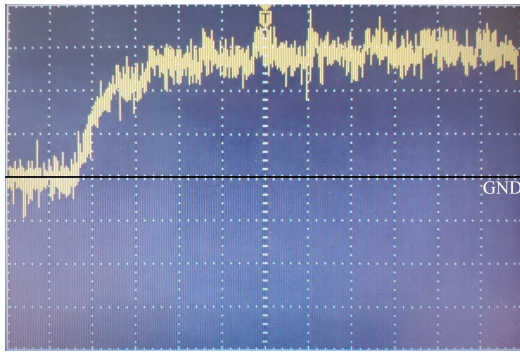

Fig. 25: The waveform of a voltage doubler rectifier circuit (2 mV/div, 500 ms/div)

5 Conclusions

This study converted the mechanical energy of pulsations into electrical energy using piezoelectric elements. The AC voltage signals thus obtained using commercially available piezoelectric elements were rectified and used to charge a capacitor. The process summary follows:

- A protrusion was inserted between the piezoelectric element and the skin for effective pulsation detection.
- The transducer output voltage was increased by using three piezoelectric elements; they were stacked by not aligning the position of the protrusions, and each piezoelectric element was individually fixed with tape so that the pulsation could be applied evenly.
- Schottky barrier diodes with low threshold voltages were used for rectification.
- A voltage-doubler rectifier circuit was used to eliminate the forward-threshold-voltage-doubling issue of diode-bridge circuits.
- Finally, capacitor charging was accomplished.

In energy-harvesting, this is the first time that the pulsations in the human body have been converted into electrical energy using piezoelectric elements.

In the absence of piezoelectric elements that can be directly used in pulsation–electricity transduction, the piezoelectric-element-stacking method used in this study could be effective. If a pulsation extraction output that exceeds twice the threshold voltage of a general-purpose diode can be obtained using a single piezoelectric element, it can be easily rectified by connecting a full-wave rectifier circuit to the general-purpose diode.

In this study, it was confirmed that the capacitor could be charged, but examining the stability of the results obtained and supplying the charge to electronic devices remain issues.

References:

- [1] S. Priya, and D. J. Inman, *Energy Harvesting Technologies*. Springer, USA, 2009.
- [2] T. Starner, Human-powered wearable computing, *IBM Systems Journal*, Vol. 35, Nos. 3&4, 1996, pp.1-12.
- [3] C. Dagdeviren, Z. Li, and Z. L. Wang, Energy harvesting from the animal/human body for self-powered electronics, *Annual Review of Biomedical Engineering*, Vol. 19, 2017, pp. 85-108.
- [4] C. G. Núñez, L. Manjakkal, and R. Dahiya, Energy autonomous electronic skin, *npj Flexible Electronics*, Vol. 3, No. 1, 2019, pp. 1-24.
- [5] R. Hesham, A. Soltan, and A. Madian, Energy harvesting schemes for wearable devices, *Int. J. Electron. Commun. (AEÜ)*, Vol. 138, 2021, pp. 1-11.
- [6] J. L. González, A. Rubio and F. Moll, Human powered piezoelectric batteries to supply power to wearable electronic devices, *Int. J. Soc. Mater. Eng. Resour.*, Vol. 10, No.1, 2002, pp. 34-40.
- [7] Q. Zheng, B. Shi, Z. Li, and Z. L. Wang, Recent progress on piezoelectric and triboelectric energy harvesters in biomedical systems, *Advanced Science*, Vol. 4, 2017, pp. 1-23.
- [8] H. Liu, J. Zhong, C. Lee, S. Lee and L. Lin, A comprehensive review on piezoelectric energy harvesting technology: Materials, mechanisms, and applications, *Applied Physics Reviews*, Vol. 5, 2018, pp. 1-35.
- [9] N. Sezer and M. Koç, A comprehensive review on the state-of-the-art of piezoelectric energy harvesting, *Nano Energy*, Vol. 80, 2021, pp. 1-25.
- [10] S. Yoon and Y. Cho, A Skin-attachable Flexible Piezoelectric Pulse Wave Energy Harvester, *Journal of Physics, Conference Series*, 557 012026, 2014, pp. 1-5.
- [11] I. Nakanishi and H. Nakamura, Extraction of a Pulse Wave Using a Piezoelectric Element Toward Energy Harvesting, *Proc. of 2022 IEEE the 4th Global Conference on Life Sciences and Technologies (LifeTech2022)*, 2022, pp. 616-618.

Contribution of Individual Authors to the Creation of a Scientific Article (Ghostwriting Policy)

Isao Nakanishi involved in all aspects of this study except for the experiments and wrote this article. Hiroyuki Nakamura produced the devices and organized and executed the experiments and considered their results. Masaya Jyouki and Yuuma Hatamoto helped with some of those.

Sources of Funding for Research Presented in a Scientific Article or Scientific Article Itself

No funding was received for conducting this study.

Conflicts of Interest

The authors have no conflicts of interest to declare that are relevant to the content of this article.

Creative Commons Attribution License 4.0 (Attribution 4.0 International , CC BY 4.0)

This article is published under the terms of the Creative Commons Attribution License 4.0

https://creativecommons.org/licenses/by/4.0/deed.en_US