

# Fuzzy Technologies for Modeling Social Capital in the Emergent Economy

VIACHESLAV DZHEDZHULA  
Department of Finances and Innovative  
Management  
Vinnytsia National Technical University  
95, Khmelnytsky highway  
UKRAINE

IRYNA YEPIFANOVA  
Department of Finances and Innovative  
Management  
Vinnytsia National Technical University  
95, Khmelnytsky highway  
UKRAINE

VIKTORIYA HUROCHKINA  
Department of Economics, Entrepreneurship  
and Economic Security, State Tax University,  
Irpın, 31, Unıversytetska str.  
UKRAINE

ANATOLY TELNOV  
Department of Marketing and Trade  
Entrepreneurship, Khmelnytsky National  
University, Khmelnytsky, 11, Instytutska str.  
UKRAINE

**Abstract:** Development of fuzzy mathematic model of identification of emergent state allows estimating the intensity of occurrence of positive emergent in the course of development of social capital. The main factors influencing the decision-making process regarding the emergent social capital have been determined. The system of social capital development is considered. As a result of modeling, we have chosen the indicator Esc - the level of emergence of social capital, which will assess the level of influence of drivers on the level of development of social capital in the modern information society of the emergent economy. The results of the study show that the indicator of the level of emergent social capital is formed on the basis of sources of structural, cognitive, relational, intellectual dimensions and dynamic processes of development of the digital environment, which promotes interaction and forms social network connections. Application of fuzzy logic in mathematic models of identification of the emergent state allows to take into account the national characteristics of the object of study and traditional and non-economic factors, at the same time, focuses on social interaction in the professional activities of the society.

**Key-Words:** - social capital, emergent, fuzzy logic, linguistic variable, digital environment, intellectual measurement

Received: July 12, 2021. Revised: January 4, 2022. Accepted: March 3, 2022. Published: March 24, 2022.

## 1 Introduction

The system of social capital development in the emergent economy focuses on social interaction in professional activities. It requires adaptability and flexibility, from banking to drawing. In the paradigm of social capital development to non-traditional and non-economic factors, should include the following: digital, information, technical and technological, environmental, energy and resource, neuro-psychological and neuro-linguistic, ethical, cultural, and religious, political and institutional, etc. To the main properties of the development system, social capital include natural and developed elements. The natural ones are:

- potential for interaction or social resources when employees achieve the results of the enterprise;
  - ability to accumulate - creating networks of social ties;
  - convertibility as an exchange on a non-equivalent basis;
  - ability to exchange and other resources in quantitative terms;
  - liquidity as an opportunity to exchange on an equivalent basis;
  - profitability as saving transaction costs of cooperation or receiving social rent.
- The developed elements of social capital include:
- corporate qualities, including the ability to work as a team;

- focus on new knowledge and self-development;
- adaptive and communicative abilities (emotional and adaptive intelligence);
- observance of moral norms and rules of conduct;
- acquired general and special (professional, subject) competencies that form an integral competence.

In Social philosophy is a phenomenon of the ideology of the information society, which is based on information anthropology and axiology, information ethics, culture, consciousness and digital culture. The information society lives in an age of ideas and creative leadership. Co-creation, self-organization and self-development of actors is a driver in the world VUCA (volatility, uncertainty, complexity and ambiguity) unstable, uncertain, complex and ambiguous. Delay in the development of social capital occurs in the absence of imagination of the subjects and a state of uncertainty, everything else is only indirect factors of influence.

## 2 Literature Review

Stimulating the self-development of subjects begins with the specific qualitative characteristics of the system of social capital development, which should include reflection (evaluation and adaptation of one's own behavior to an effective result) and the level of adaptive intelligence of subjects (economic agents) in unpredictable operating conditions (speed of adaptation, communication, speed of recovery "resilience").

R. Putnam, who argued that "social capital is associated with personal connection in social networks, which is reliable and reciprocal" [1]. Social capital is based on social interaction, ie it is a driver of social networks for productive work in society. The convergence of the "social" part to the term "capital" acquires a new meaning - intangible, as we cannot touch it, consider, and therefore the study of social capital requires non-standard approaches. And such a characteristic of social capital as the emergence of new qualities of a system refers to emergent properties.

Firms with high social capital systematically outperform their peers during periods of economic distress [2]. Social capital hedging firms against systematic shocks by mitigating employee-related litigation risk.

In [3] the value appropriation involving startups and examines the relationship between founder social capital and value obtained by startups in R&D alliance agreements are considered.

The formation of digital culture, ethics, tolerance and virtual patience in the period of formation of the information society are also specific qualitative indicators of the effectiveness of the system of social capital development.

The theoretical essence of the concept of "resilience" is interpreted as resilience, replenishment of personal resources, the ability of the subject to cope relatively well with difficult situations, the potential for recovery, return to previous physical and psychological states associated with psychological stress and trauma. As noted by N. Gusak and V. Chernobrovkina "in Ukraine the use of the concept of resilience approach began in 2017, due to the psychological trauma of society due to hostilities in the country" [4].

The convergence of elements of economic and socio-emotional dimensions of the theory of social exchange and the strength of their impact on people's participation in joint economic activities has led to transition from the economy of attention to the economy of participation, in which the achievement of ecommunication and the development of social skills through the effects of involvement.

Horizon 2020, one of the parts of the European Union's research project, focuses on participatory or shared economics: "Ps2Share Participation, Privacy, and Power in the Sharing Economy" [5]. The main goal is to identify the key challenges of the sharing economy and to improve European digital services by making recommendations to European institutions. The initial phase of this research project includes a set of three literature reviews on the state of research on three main topics related to the sharing economy: participation, privacy and power. The formation of an economy of participation or sharing is a specific quantitative indicator of the effectiveness of the system of social capital development in the country.

The experience of stimulating creative thinking in the system of social capital development has shown results in the application of practice-oriented approach problem-based learning (PBL, Project Based Learning). As Ulger K. notes, "PBL had a significant impact on creative thinking, but a tendency to think critically to a lesser extent. One of the possible reasons for this result is the use of non-programmatic problem-solving process for the development of creative thinking [6]. That is, such an approach based on problem-based learning is the basis for building relationships of non-core problem-solving processes, maintaining uncertainty

and enhancing creative thinking, but will not affect the emergence of critical thinking.

Creating a knowledge management system that will ensure high competitiveness of enterprises and organizations and their innovative growth in the concept of innovative progress is a specific quantitative indicator of the effectiveness of social capital development. According to Ilyashenko S. M. and the team of authors "organizational and economic mechanism of knowledge management will determine the priority areas of knowledge production on global (industry, market) trends and existing potential, choose effective ways to apply these areas by creating and implementing (commercializing) product, technology, management and other innovations" [7].

Thus, the above characteristics of quantitative and qualitative systemic effects (synergistic and emergent) are achieved through the interaction of agents. As for the emergent effects, they have a dualistic nature, which has the characteristics of achieving multi-vector results of activities or a double trajectory of functioning with different results in one plane - ambiguous activity. In modern economics it is called ambidexterity or ambidexterity.

Ambidextria (from Latin *ambo* - both + *dextri* - right), Ambidexterity, ambidexterity (translated from English. ambidexterity -ambiguity, ambiguity) at the level of the economic system should be considered as the ability to synchronously conduct different processes while maintaining a balance of interests and using the inherent capabilities of the components of the system.

Hughes M. exploring organizational ambidexterity combines the art of management at the level of organizational structure and design, while at the individual level in terms of people's skills, leadership and work in general. However, he notes that "we realize that we may not need to do everything ourselves" [8] and highlights six basic recurring elements of organizational ambidexterity that we must appreciate if we want to understand this phenomenon and interpret it correctly, namely: timeliness and punctuality, survival of the organization, compromise and balance, load management, greatness and importance, synchronicity and agility.

Under conditions of emergence ambidextric properties in the economic system (or in the agent at the micro-level), there is an effect of resistance to the operating environment. A feature of the strategic strength of the economic system is the timely identification of resistance and activation of adaptive capacity and resilience to

eliminate/mitigate negative factors. In [9] the mathematical model has been developed to support intellectual decision-making on the optimal balance of financial security for the innovative activities of industrial enterprises in the face of a shortage of financial resources, is presented as a set of fuzzy logical equations. In [10] proposed scientific and methodological approach for estimating emergent properties, based on the modeling of processes according to the theory of fuzzy logic, where the information base became the dynamic changes in the functioning of mechanical engineering enterprises, the system of organizational and organizational acceptance technological.

### 3 Methodology

Emergence, as an emerging phenomenon, characterizes the set of properties of the system that is a consequence of unpredictable bifurcation in a dynamic environment. environment and quantitative and qualitative new properties that were not inherent in both the sum of the components of the system as a whole and its individual elements [11].

Social capital arises due to the convergence of its constituent elements and is an emergent effect with different scenarios of strategic development (dualistic attractor and ambidexterity). The system of social capital development is shown at fig. 1.

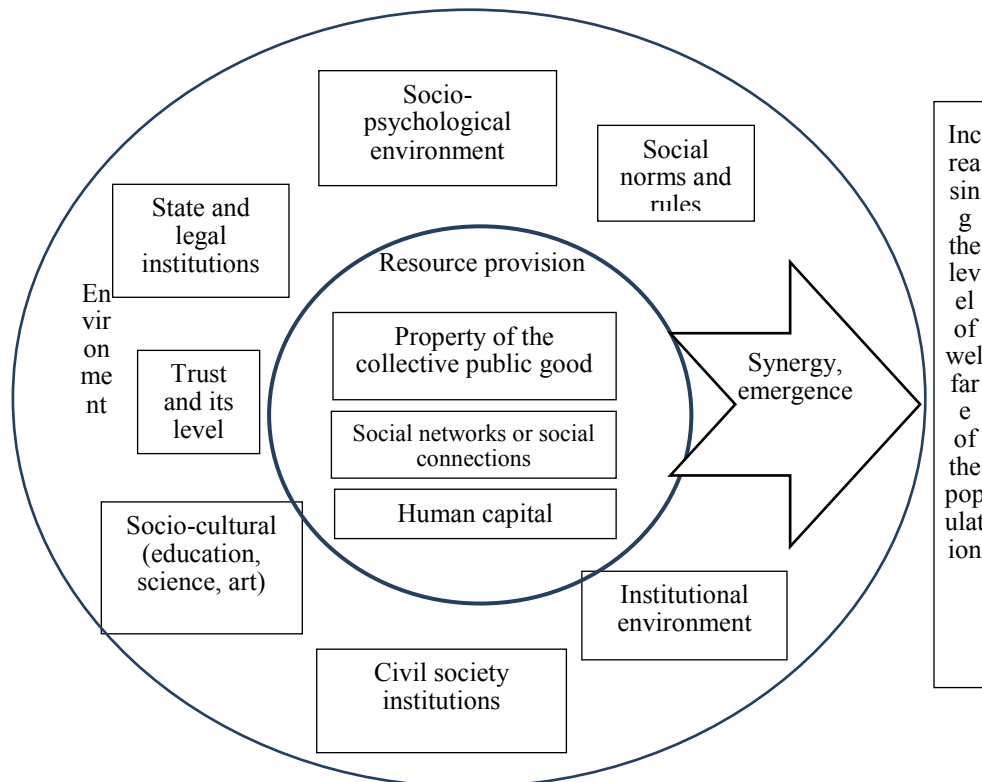

Fig. 1: The system of social capital development

The immanence of the nature of the development of a scenario depends on the potential of the economic system and the factors of influence at the time of bifurcation.

For developing a mathematical model based on fuzzy technologies for modeling the measurement of social capital in the emergent economy on the example of social capital of Ukraine groups of measurement of influencing factors are selected, which are classified according to various features and divided into five subgroups: structural, cognitive, relational, intellectual, digital. Typically, such indicators are qualitative and quantitative.

Scientific and methodological approach to assessing the level of influence of drivers of social capital development in the emergent economic system using the theory of fuzzy logic is to measure the level of emergence of social capital in a certain range. As a result of modeling, we have chosen the indicator  $Esc$  - the level of emergence of social capital, which will assess the level of influence of drivers on the level of development of social capital in the modern information society of the emergent economy (fig. 2).

## 4 Results and Discussion

Linguistic variable (LV), which corresponds to the indicator of the level of emergence of social capital in the emerging economy  $Esc$  can be represented as a ratio:

$$Esc = f(X, Y, Z, W, Q), \quad (1)$$

where  $Esc$ - indicator of the level of emergent social capital;

$X$  is a linguistic variable that describes the influence of sources of structural dimension;

$Y$  - linguistic variable that describes the impact of cognitive dimensions that affect social capital;

$Z$  is a linguistic variable that describes the influence of the relational dimension, which affects the formation of relationships,

$W$ - linguistic variable that describes the impact of the intellectual dimension, which characterizes the level of development of social capital in the economy of emergent influence,

$Q$  - linguistic variable that describes the impact of the level of development of the digital environment.

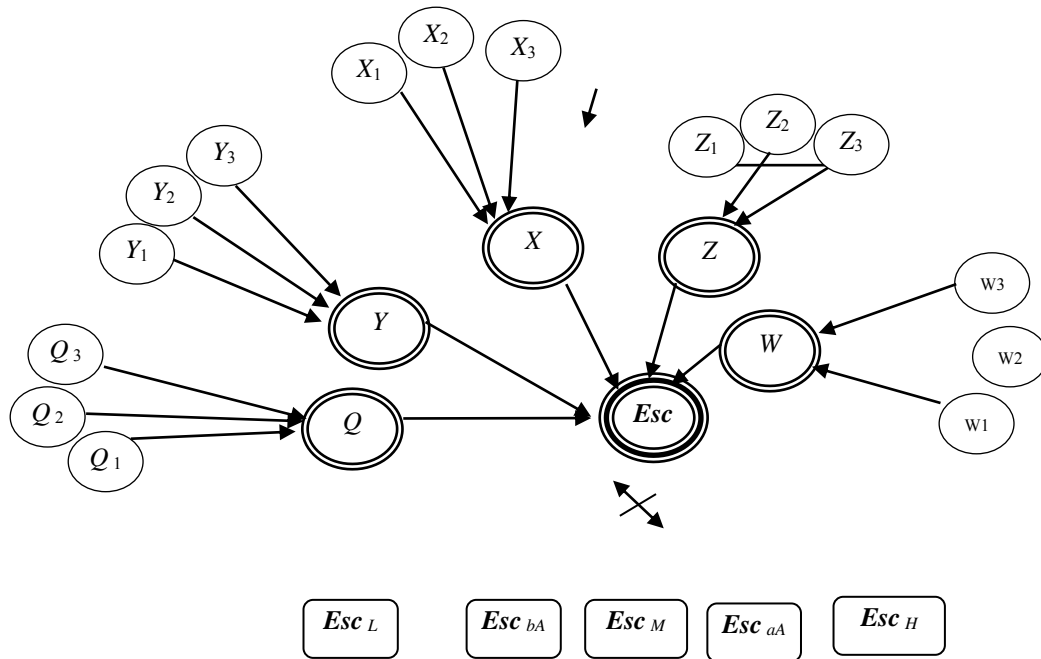

Fig. 2: Tree of hierarchical connection of formation and development social capital

The linguistic variable describing the emergent structural dimension can be expanded as follows:

$$X = f(x_1, x_2, x_3), \quad (2)$$

where  $x_1$  - linguistic variable s “architecture of structure” (the ratio of women to men);

$x_2$  - linguistic variable "level of trust";

$x_3$  - linguistic variable "social well-being and public mood";

The linguistic variable describing the emergent cognitive dimension can be expanded as follows:

$$Y = f(y_1, y_2, y_3), \quad (3)$$

where  $y_1$  - LV "psychological distress";

$y_2$  - LV "anomie (lack of norms)";

$y_3$  - LV "values";

The linguistic variable describing the emergent dimensions of relational dimension can be expanded as follows:

$$Z = f(z_1, z_2, z_3), \quad (4)$$

where  $z_1$  is LV “index of national distance”;

$z_2$  - LV “index of state subjectivity of Ukraine”;

$z_3$  - LV "index of social tension";

The linguistic variable describing the emergencies of the intellectual dimension can be expanded as follows:

$$W = f(w_1, w_2, w_3), \quad (5)$$

where  $w_1$  - linguistic variable "adaptive intelligence";

$w_2$  - linguistic variable "emotional intelligence";

$w_3$  - LV “ integral index of social well-being”;

The linguistic variable that describes the emergence of the digital environment can be deployed as follows:

$$Q = f(q_1, q_2, q_3), \quad (6)$$

where  $Q_1$  - LV "digital infrastructure";

$Q_2$  - LV "digital ethics and trust";

$Q_3$  - LV "online services";

Table 1 shows the universal sets of variations of factor values, units of measurement, and linguistic terms for evaluation by experts.

A similar situation with the membership functions of the variable  $E_{sc}$ . The number of membership functions for this variable corresponds to the number of linguistic terms - 5; function definition range [0... 10]. Other membership functions are built into the program in a similar way using the built-in Fuzzy logic designer packages.

The mathematical model of identification of the emergent state of social capital is presented in the form of a set of fuzzy logical equations, which are

formed on the basis of information from knowledge bases.

Mathematical model of intelligent decision support with the definition of the dimension of social capital in the emergent economy is represented by a set of fuzzy logical equations based on information obtained from the knowledge base. A fragment of the mathematical model is presented below:

$$\begin{aligned} &\mu_{gi}(x_1) \wedge \mu_d(x_2) \wedge \mu_{la}(x_3) \wedge \mu_1(y_1) \wedge \mu_p(y_2) \wedge \mu_{abs}(y_3) \wedge \mu_1(z_1) \wedge \mu_d(z_2) \wedge \mu_h(z_3) \wedge \mu_d(w_1) \wedge \mu_1(w_2) \wedge \\ &\mu_{zvr}(w_3) \wedge \mu_{gsg}(q_1) \wedge \mu_{ritcrit}(q_2) \wedge \mu_1(q_3) \vee \mu_{gi}(x_1) \wedge \mu_d(x_2) \wedge \mu_1(x_3) \wedge \mu_u(y_1) \wedge \mu_h(y_2) \wedge \mu_{abs}(y_3) \wedge \mu_1(z_1) \wedge \\ &\mu_d(z_2) \wedge \mu_h(z_3) \wedge \mu_d(w_1) \wedge \mu_1(w_2) \wedge \mu_{hap}(w_3) \wedge \mu_{gsg}(q_1) \wedge \mu_{ritcrit}(q_2) \wedge \mu_{bsabs}(q_3) \vee \mu_{gi}(x_1) \wedge \mu_d(x_2) \wedge \\ &\mu_{ha}(x_3) \wedge \mu_u(y_1) \wedge \mu_p(y_2) \wedge \mu_{vapor}(y_3) \wedge \mu_1(z_1) \wedge \mu_d(z_2) \wedge \mu_h(z_3) \wedge \mu_d(w_1) \wedge \mu_1(w_2) \wedge \mu_{zvr}(w_3) \wedge \mu_{gsg}(q_1) \wedge \\ &\mu_{qa}(q_2) \wedge \mu_{bsabs}(q_3) \vee \mu_{gi}(x_1) \wedge \mu_d(x_2) \wedge \mu_1(x_3) \wedge \mu_u(y_1) \wedge \mu_p(y_2) \wedge \mu_{abs}(y_3) \wedge \mu_{za}(z_1) \wedge \mu_{chad}(z_2) \wedge \mu_h(z_3) \wedge \\ &\mu_d(w_1) \wedge \mu_1(w_2) \wedge \mu_{zvr}(w_3) \wedge \mu_{gsg}(q_1) \wedge \mu_{ritcrit}(q_2) \wedge \mu_1(q_3) \vee \mu_{gi}(x_1) \wedge \mu_d(x_2) \wedge \mu_1(x_3) \wedge \mu_u(y_1) \wedge \mu_p(y_2) \wedge \mu_{abs}(y_3) \wedge \mu_{za}(z_1) \wedge \mu_d(z_2) \wedge \mu_h(z_3) \wedge \\ &\mu_d(w_1) \wedge \mu_1(w_2) \wedge \mu_{zvr}(w_3) \wedge \mu_h(q_1) \wedge \mu_{qa}(q_2) \wedge \mu_{bsabs}(q_3) = \mu_H(Esc); \end{aligned} \tag{7}$$

Using a knowledge base and a set of fuzzy logical equations allows you to perform process

modeling measurement of social capital in the emergent economy. For the processing of fuzzy information, phasing and dephasing it is necessary to use specialized software packages that allow obtaining the predicted data automatically without manual calculations. One such complex is the Matlab mathematical package. Formed mathematical model in the mathematical package Simulink Matlab (Fig. 3).

This model allows us to determine the value of social capital in the emergent economy. The calculation is performed as follows: the values of the input variables obtained by experts or calculated analytically are entered into the blocks of constants at the input of the model. The integration units supply an input signal to the input port of the fuzzy Fi model. Then the program performs calculations and the signal is fed to the display unit in the form of a numerical value - the predicted value - indicator of the level of emergence of social capital in the emerging economy.

The window of the virtual oscilloscope with the value of the simulation result for 2018 is shown in Figure 4.

Table 1. Influencing factors as linguistic variables

Designation and name of the variable	Universal set of variations	Linguistic terms for estimating the factor and its limits
<b>structural dimension factors (X)</b>		
$x_1$ - LV "architecture of structure"	$U(x_1) = \{0... 10\}$ (gap)	Gender inequality (gi), [0-5]: average (a), [5.1-7.5] equal (e) [7.6-10]
$x_2$ - LV "level of trust"	$U(x_2) = \{0... 10\}$ (items)	Distrust (d), [0-3.9]; average confidence level (mt), [4-7.5] trust (t) [7.51-10]
$x_3$ - LV "social well-being and public mood"	$U(x_3) = \{0... 10\}$ (items)	Low (l), 0-1.5; below average (la), [1.6-2.5]; average (a), [2.6-5]; above average (ha), [5.1-7.5] high (h) [7.6-10]
<b>cognitive measurement factors (Y)</b>		
$y_1$ - LV "Psychological distress"	$U(y_1) = \{0... 10\}$ (items)	Unsatisfactory (u), [0-2.4]; low (l), [2.5-4.4]; satisfactory (s), [4.5-6.99]; sufficient (suf), [7-8.5] high (h) [8.4-10]
$y_2$ - LV "anomie (lack of norms)"	$U(y_2) = \{0... 10\}$ (items)	Present (p), [10-8]; high (h), [6.01-7.99] average (a), [4.5-6]; low (l), [2.5-4.49] absent (abs) [0-2.4]
$y_3$ - LV "values"	$U(y_3) = \{0... 10\}$ (items)	Absent (abs), [0-3.99]; Partial (pair), [4-6.5] Steel (const) [6.51-10]

<b>factors relational measurement (Z)</b>		
$z_1$ - LV «index of national distance»	$U(z_1) = \{0 \dots 10\}$ (items)	Low (l), [8.6-10]; average (a), [5.6-8.5] partial (pair), [3.6-5.5]; high (h), [2.01-3.5] full [0-2]
$z_2$ - LV «index of state subjectivity of Ukraine»	$U(z_2) = \{0 \dots 10\}$ (items)	Destruction (d), [0-1.99]; vector changes (vc), [2-3.5] device (ad), [3.6-5.5]; integration (i), [5.6-7.5] transformation (t) [7,6-10]
$z_3$ - LV "index of social tension"	$U(z_3) = \{0 \dots 10\}$ (items)	High (h), [10-7.5]; average (a), [7.49-5.5] below average (la), [4.99-3]; low (l) [0-2.99]
<b>factors of intellectual measurement (W)</b>		
$w_1$ - LV "Adaptive Intelligence"	$U(w_1) = \{0 \dots 10\}$ (items)	Destruction (d), [0-2]; average (a), [2.1-3.5] partial (pair), [3.6-5.5]; moderate (m), [5.6-7.5] strong full (df) [7.6-10]
$w_2$ - LV "emotional intelligence"	$U(w_2) = \{0 \dots 10\}$ (items)	Low (l), [0-2]; average (a), [2.1-3.5] partial (pair), [3.49-5.99]; high (h), [6-7.99] full [8-10]
$w_3$ - LV «integral index of social well-being»	$U(w_3) = \{0 \dots 10\}$ (items)	Despair (ZVR), [0-2.8]; average (a), [2.9-4] security (sec), [4.01-6.5]; happiness (hap) [6.6-10]
<b>factors emerging in the digital environment (Q)</b>		
$Q_1$ - LV "digital infrastructure"	$U(Q_1) = \{0 \dots 10\}$ (items)	Significant gap (sg), [0-2]; low (l), [2.01-2.5] average (a), [2.6-5]; developed (dev), [5.01-7.59] high (h) [7.6-10]
$Q_2$ - LV «digital ethics and trust »	$U(Q_2) = \{0 \dots 10\}$ (items)	Critical, [0-2.59]; low (l), [2.6-3.5] average (a), [3.51-6.5]; high (h) [6.51-10]
$Q_3$ - LV "online services"	$U(Q_3) = \{0 \dots 10\}$ (items)	Absent (abs), [0-2.5]; low (l), [2.51-3.5] average (a), [3.6-6.5]; developed (dev) [6,6-10]

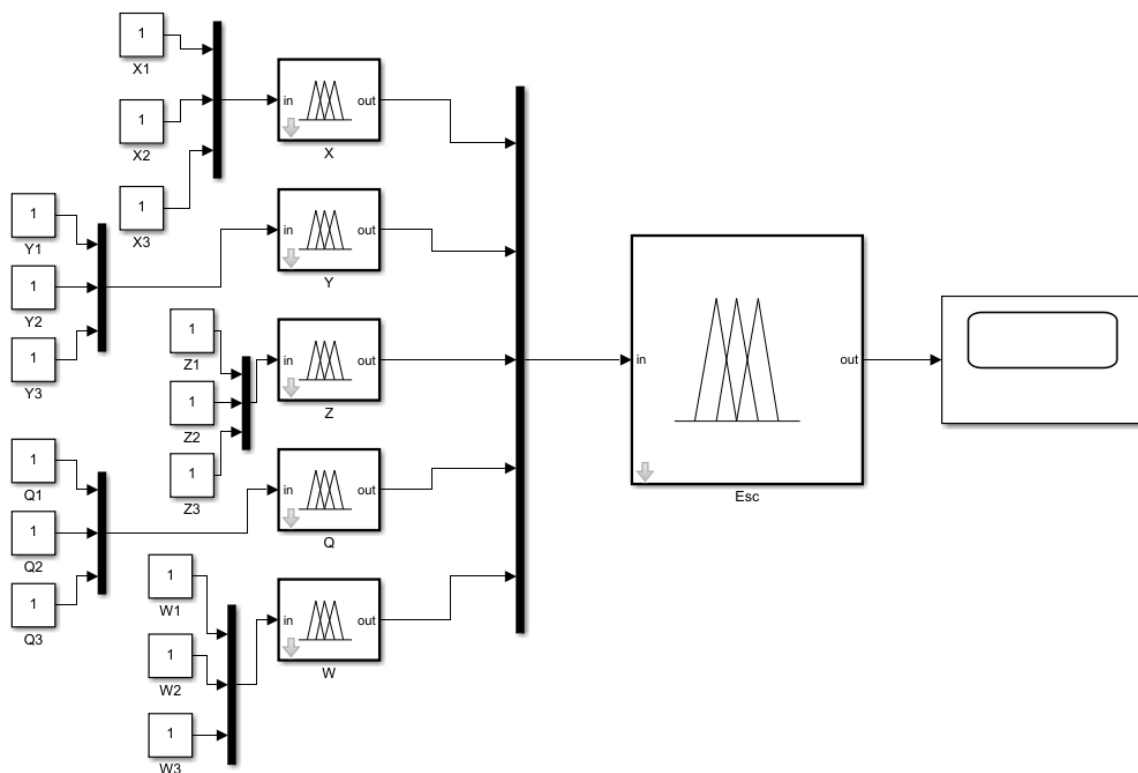

Fig. 3: Fuzzy mathematical model of measuring social capital in the emergent economy

Table 2. Simulation results

Year	x <sub>1</sub>	x <sub>2</sub>	x <sub>3</sub>	y <sub>1</sub>	y <sub>2</sub>	y <sub>3</sub>	z <sub>1</sub>	z <sub>2</sub>	z <sub>3</sub>	w <sub>1</sub>	w <sub>2</sub>	w <sub>3</sub>	Q <sub>1</sub>	Q <sub>2</sub>	Q <sub>3</sub>	Soc cap	Esc
2016	0.88	1.9	2.25	0.6	0.75	1.3	2.4	3	1.8	3.0	3.58	3.1	3.72	1.2	5.12	4.14	2.37
2017	0.93	1.8	2.42	0.6	0.8	1.4	3.5	3.15	2.0	2.8	2.11	3.3	3.80	1.4	5.24	4.30	2.39
2018	0.88	1.9	2.71	0.7	0.9	1.5	4.3	3.2	3.2	2.9	1.92	3.4	3.96	1.5	5.87	4.60	2.67
2019	0.88	2.6	3.47	1	1.2	1.8	5.3	4.0	3.5	3.0	2.14	4.0	4.36	1.4	5.69	5.33	2.89
2020	0.83	2.2	2.37	1.4	1.6	2.1	6	4.6	4.8	3.1	4.23	4.7	5.94	1.3	6.82	6.26	3.47

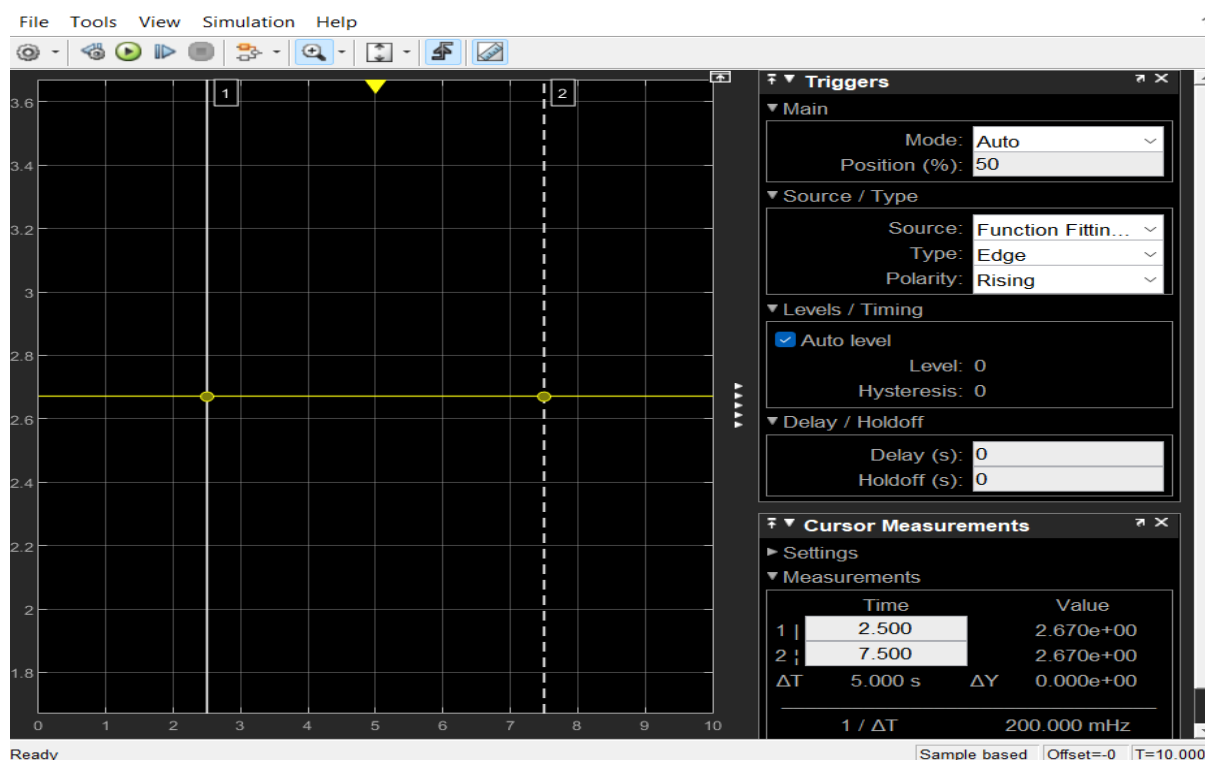

Fig. 4: The simulation results for 2018 are displayed in the virtual oscilloscope window

Development level social capital is in Ukraine in 2020 6.26 points on a scale from 0 to 10, which compared to 2016 is 4.14 points more than 51.20%. With such data, the level of emergent state of social capital in 2020 is 3.47 points on a similar scale, ie the state of emergence is 55.43% in 2020, respectively, according to the dynamic changes in the level of social capital development over the years, it should be noted that the state of emergence is: 54.22% in 2019, 58.04% in 2018, 55.58% in 2017, 57.24% in 2016

### 5 Conclusion

Developed fuzzy mathematic model of identification of emergent state allows estimating

the intensity of occurrence of positive emergent in the course of development of social capital. The study of the system of social capital development in the emergent economy on the example of Ukraine showed that the indicator of the level of emergent social capital is formed on the basis of sources of structural, cognitive, relational, intellectual dimensions and dynamic processes of development of the digital environment, which promotes interaction and forms social network connections. Application of fuzzy logic in mathematic models of identification of the emergent state allows to take into account the national characteristics of the object of study and-traditional and non-economic factors, at the same time, focuses



on social interaction in the professional activities of the society.

#### References:

- [1] Putnam R. D, Leonardi R., Nanetti R. J. (2001) Creation of democracy. Traditions of creating public activity in modern Italy. K.: Fundamentals.
- [2] Franco Fiordelisi, Giuseppe Galloppo, Gabriele Lattanzio (2021) Where does corporate social capital matter the most? Evidence From the COVID-19 crisis. Finance Research Letters, <https://doi.org/10.1016/j.frl.2021.102538>
- [3] Ramakrishna Devarakonda, Jeffrey J. Reuer, Harsha Tadikonda (2022) Founder social capital and value appropriation in R&D alliance agreements. Research Policy 51, 104474. <https://doi.org/10.1016/j.respol.2022.104474>.
- [4] Gusak, N., Chernobrovkina, V., (2017). Psychosocial support in emergencies: resilience approach: teaching method. manual. Nat. University "Kyiv-Mohyla Academy". Kyiv: NaUKMA
- [5] Horizon 2020. Ps2Share Participation, Privacy, and Power in the Sharing Economy. URL:<https://cordis.europa.eu/project/id/732117>
- [6] Ulger K. (2018) The effect of problem-based learning on the creative thinking and critical thinking disposition of students in visual arts education. Interdisciplinary Journal of Problem-Based Learning, 12 (1). URL: <https://doi.org/10.7771/1541-5015.1649>
- [7] Illiashenko, SM, Shipulina, Yu. S., Illiashenko NS, Komarnicka, G. A. (2017). Knowledge management in the system of organization's innovative development. Marketing and Management of Innovations, (1), 231–241. <https://doi.org/10.21272/mmi.2017.1-21>.
- [8] Hughes, M. (2018). Organizational ambidexterity and firm performance: burning research questions for marketing scholars. Journal of Marketing Management.
- <https://doi.org/10.1080/0267257X.2018.1441175>
- [9] Voynarenko M., Dzhezdzhula V., Yepifanova, I. (2016) Modelling the process of making decisions on sources of financing of innovation activity. Economic AnnalsXXI, 160(7-8), pp. 126-129
- [10] Voynarenko M., Hurochkina V., Dzhezdzhula V., Yepifanova I. Yu., Menchynska O. (2021) Applying Fuzzy Logic to Modeling Economic Emergence WSEAS Transactions on Business and Economics, Volume 18, pp. 424-434.
- [11] Gurochkina V. V. (2020) Financial and integration mechanisms of industrial enterprises development in emergent economy: author's ref. dis ... Dr. Econ. Sciences: 08.00.04 / VV Gurochkina, Khmelnytsky. nat. un-t. Khmelnytsky: KhNU, 2020.

#### Contribution of Individual Authors to the Creation of a Scientific Article (Ghostwriting Policy)

Viacheslav Dzhezdzhula has implemented model design, data analysis, implementation of modelling, methodology.

Hurochkina Viktoriya was responsible for conceptualization, formal analysis, methodology.

Iryna Yepifanova was the author of the idea, structuring the factors, was responsible for methodology

Anatoly Telnov was responsible for conceptualization, methodology.

#### Creative Commons Attribution License 4.0 (Attribution 4.0 International, CC BY 4.0)

This article is published under the terms of the Creative Commons Attribution License 4.0

[https://creativecommons.org/licenses/by/4.0/deed.en\\_US](https://creativecommons.org/licenses/by/4.0/deed.en_US)