

Real-Time Simulation of V/F Scalar Controlled Induction Motor using RT-Lab Platform for Educational purpose

A. Idir¹ & M. Kidouche¹

¹Applied Automation Laboratory, F.H.C., University of Boumerdes,
1 Av. de l'Independance, 35000 Boumerdes, Algeria
e-mail: idir_ah@ yahoo.fr

Abstract— This paper presents a full digital implementation of an open loop Volt-per-Hertz (V/F) Controlled Induction Motor Drive using RT-Lab Software and Matlab/Simulink environment for educational purpose. RT-Lab platform offers multiple advantages from the point of education and gives a powerful tool for the teaching of induction motor parameters identification and drives. Moreover, thanks to this concept of digital real-time simulation, the students can easily put into practice a lot of theoretical knowledge.

Keywords- Induction Motor; V/F control; Real time simulation; Rapid prototyping; Educationnal purpose, RT Lab Introduction

I. INTRODUCTION

Over the years, it has been increasingly acknowledged how important and essential the tools of real-time simulation and testing in all industries. These tools are no longer a luxury in modern system design, especially in electric motor drives and power electronics. Several well-known commercial software packages such as Matlab-Simulink, Auto-CAD, Mathcad, OrCAD PcPice, RT-LAB offers many other useful toolboxes for many electrical machines in engineering subjects [1–5]. The direct use of these software packages is a major advancement in simplifying simulation procedures for many practicing engineers as well as for undergraduate engineering students [6].

RT-LAB is a powerful, modular, distributed, real-time platform that lets the engineer and researcher to quickly implement block diagram Simulink models on PC platform, supporting thus the model-based design method by the use of rapid prototyping and hardware-in-the-loop simulation of complex dynamic systems.

The major elements integrated in this real-time platform are:

- Distributed processing architecture;
- powerful processors;
- high precision and very fast input/output interface;
- hard real-time scheduler;
- And modeling libraries and solvers specifically designed for the highly non-linear motor drives

(BLDC, PMSM and Induction motors), powerelectronics, and power systems.

Real-time simulation consists of converting the Simulink model of the complete system (plant and controller) to real-time software that is uploaded to RT-LAB real-time platform (simulator) to conduct fully digital real-time simulation of the complete system.

This paper presents a full digital real-time simulation of an open loop Volt-per-Hertz (V/F) Controlled Induction Motor using RT-Lab Software and Matlab/Simulink environment for educational purpose. It uses the popular MATLAB/Simulink as a front-end for editing and viewing graphic models in block-diagram format. The block diagram models become the source from which code can be automatically generated, manipulated and downloaded onto target processors (Pentium and Pentium-compatible) for real-time or distributed simulation.

II. REAL TIME SIMULATION PLATFORM

Figure.1 below shows the concept of digital real-time simulation of an induction motor drive system.

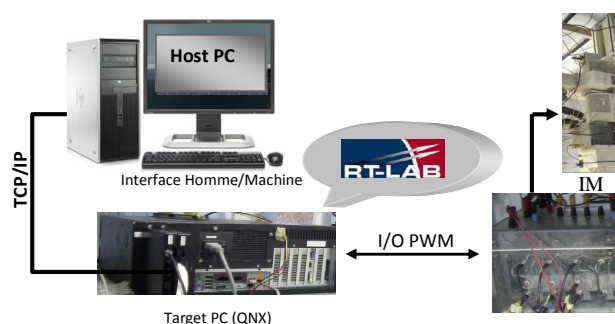

Figure 1. RT Lab Real-time Simulator Architecture.

The drive system developed includes an induction motor. The test bench is also equipped with a semikron inverter fed by the DC voltage issued to a bridge rectifier output connected to the three-phase AC supply 400/230V-50 Hz, RT-Lab Target (16 Analog input(OP5340),16 Analog output(OP5330), 32 Digital I/O (OP5311-5312)) and a personal computer with MATLAB/Simulink/RT-Lab software to design a simulate induction machine control. The simulator uses the following

communication link (Ethernet connection (100 Mb/s) between the hosts and target PC's).

As shown in Figure 2, RT-Lab [5] uses Matlab/Simulink as a front-end interface for editing graphic models in block-diagram format, which are afterwards used by this real-time simulator to generate the necessary C-code for real-time simulations on a single or more target processors running QNX.

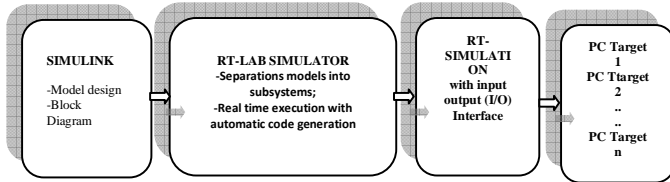

Figure 2. Principle of Real-time Simulation using RT-Lab

III. OPEN LOOP V/F SCALAR CONTROL

In scalar control schemes the phase relations between IM space vectors are not controlled during transient. The control scheme is based on steady state characteristics, which allows stabilization of the stator flux for different speed and torque values. In many industrial applications, the requirements related to the dynamic properties of drive control are of secondary importance. In such cases the open-loop constant voltage/Hz control system is usually used.

Figure 3. below shows the scheme of constant V/F controller. The IM was controlled by controlling the amplitude of the input voltage and the operating frequency.

A fixed value of slip velocity, ω_{sl} , (corresponding to 50% of rated torque), is added to the reference velocity, ω_M^* , of the motor to result in the reference synchronous frequency, ω_s^* . This frequency is next multiplied by the number of pole pairs, P_p , to obtain the reference output frequency, ω^* , of the inverter, and it is also used as the input to the voltage calculator.

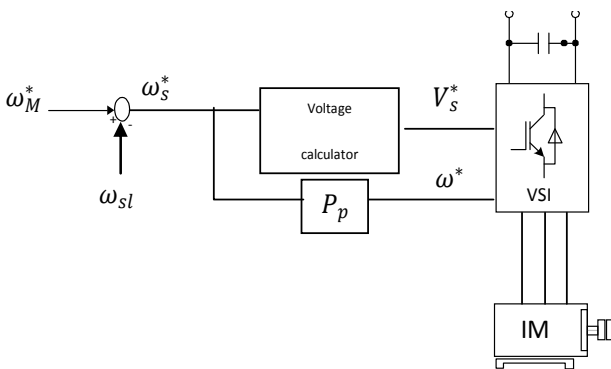

Figure 3. Basic Open Loop V/F Scalar Control

At low speed, the voltage drop across the stator resistance must be taken into account in maintaining constant flux. Conversely, at speeds exceeding that corresponding to the rated frequency, ω_{rat} , the constant V/F condition cannot be satisfied because it would mean an overvoltage. Therefore the

stator voltage is calculated in accordance to the following equation:

$$V_S = \begin{cases} (V_{srat} - V_{boost}) \frac{\omega}{\omega_{rat}} + V_{s0} & ; for \omega \leq \omega_{rat} \\ V_{srat} & ; for \omega > \omega_{rat} \end{cases}$$

where V_{srat} is the stator rated voltage, ω_{rat} is the rated frequency and V_{s0} denotes the rms value at zero frequency as illustrated in Figure 4.

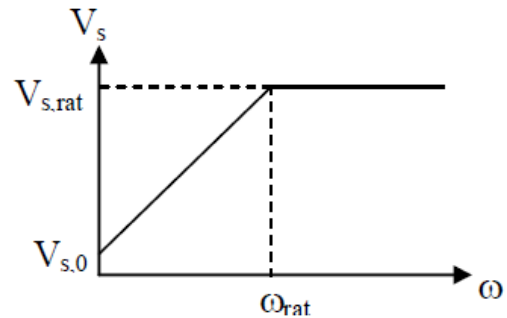

Figure 4. Voltage versus frequency relation

IV. REAL-TIME SIMULATION

Figure 5. below give the real time model of an open loop V/F scalar control of an induction motor (IM) as implemented in RT-Lab environment. RT-Lab allows to model a subsystem in MATLAB simulink environment with some own rules and perform automatic code generation and transfer of the simulink model for the FPGA implementation. Fig. 11 shows the subsystem modelled for the present controller. Subsystem named "SM_Computation_IM" contain the model of the open loop V/F control, while subsystem named "SC_Console_IM" represent the model for user interface for online data acquisition.

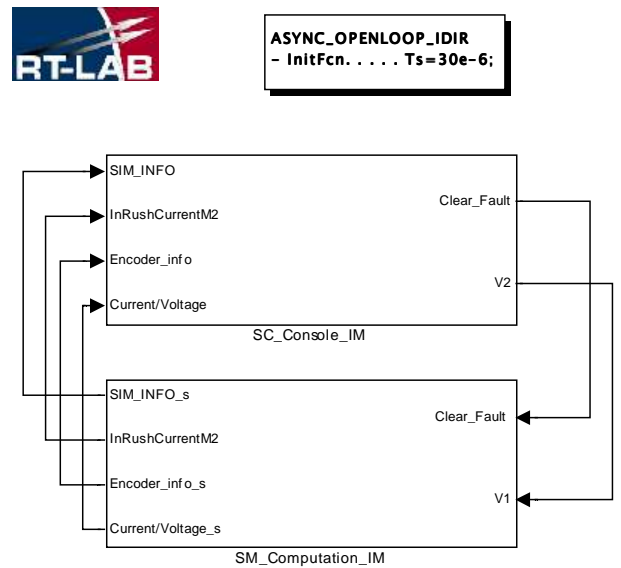

Figure 5. RT-Lab model of open loop V/F scalar control of an Induction motor

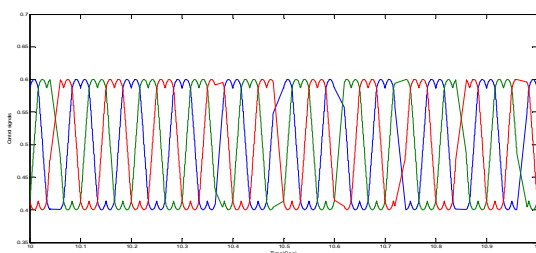

Figure 9. Real time simulation of Control signals

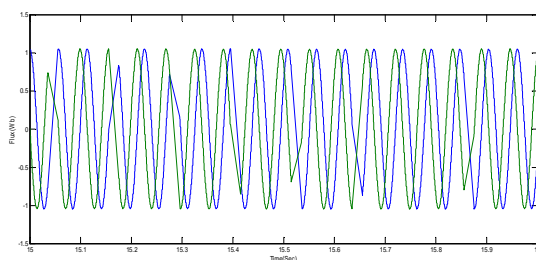

Figure 10. Real time simulation of flux response

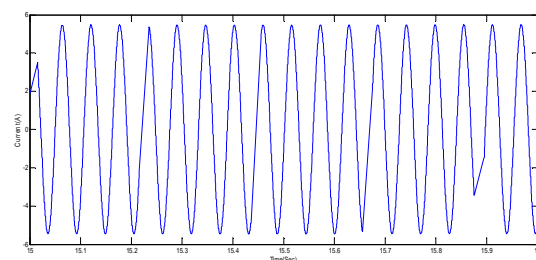

Figure 11. Real time simulation of Stator current

Simulation results showed the effectiveness of this powerful tool, which is now widely used for Rapid Control Prototyping and Hardware in the Loop applications.

VI. CONCLUSIONS

In this work, we have presented a real-time simulation of V/F scalar controlled induction motor using RT-Lab platform and Matlab/Simulink environment for educational purpose. Also this paper is an important contribution to rapid prototyping of high performance induction machine controllers since real time simulations are required by hardware in the loop applications.

REFERENCES

- [1] G. Bengu and W. Swart, A computer aided, total quality approach to manufacturing education in engineering, *IEEE Trans Educ* 39 (1996), 415–422.
- [2] OrCAD Pspice, OrCAD, Inc., Beaverton OR 970087137, 2003.
- [3] Matlab-Simulink, Mathworks, Inc., Natick MA 017602098, 2003.

- [4] ModelSim, Atmel, Inc., 2325 Orchard Parkway, San Jose, CA 95131,2003.
- [5] RT-LAB, Opal-RT Technologies, Inc., 1751 Richardson Suite 2525 Montreal Qu'ebec H3K 1H6 Canada, 2003.
- [6] M. A. Akcayol, A. Cetin, and C. Elmas, An educational tool for fuzzylogic-controlled BDCM, *IEEE Trans Educ* 45 (2002), 33–42.
- [7] J. Makwana, A. Mishra, P. agarwal and S.P Srivastava, "Implementation of low cost switched reluctance motor drive using RT-Lab", *International Journal of Engineering Science & Advanced Technology*, Volume-2, Issue-4, 772 – 780 (2012)
- [8] M. Ouhrouche, N. Léchevin and S. Abourida, RT-Lab Based Real-Time Simulation of a Direct Field-Oriented Controller for an Induction Motor, *Proceedings of the 7th International Conference on Modeling and Simulation of Electric Machines, Converters and Systems*, Montreal, Canada, Aug18-21, 2002.
- [9] [S. Beaulieu, M. Ouhrouche, C. Dufour and P.F. Allaire: "Real-time Modeling and Simulation of an Active Power Filter", *Proceedings of Ninth IASTED International Conference on Power and Energy Systems – PES'2007*, Clearwater, Florida, USA, January 3-5, 2007.
- [10] M. Ouhrouche, R. Beguenane and M. Dube-Dallaire, Real-time Simulations: A New Powerful Tool for Rapid Prototyping of High Performance Induction Machine Controllers, *Proceeding of the IASTED International Conference on Applied Modeling and Simulation*, Rhodes, Greece, June 28-30, 2004.
- [11] S. Abourida, "Real-Time PC-Based Simulator of Electric Systems and drives, *Proceedings of APEC'2002*.
- [12] C. Dufour, S. Abourida and J. Belanger, "Real-Time Simulation of Induction Motor IGBT Drive on a PC-Cluster, *Proceedings of the International Conference on Power Systems Transients (ICPST'03)*, Hong Kong, 2003
- [13] Wei Chen ; Dianguo Xu ; Rongfeng Yang ; Yong Yu ; Zhuang Xu "A novel stator voltage oriented V/F control method capable of high output torque at low speed," *International Conference on Power Electronics and Drive Systems, PEDS2009*, 2-5 Nov. 2009, pp 228 - 233.
- [14] I. Boldea," Control issues in adjustable speed drives " *IEEE Industrial Electronics Magazine*, Vol. 2, No. 3, Sept. 2008, pp. 32 - 50.
- [15] A. Munoz-Garcia, T.A. Lipo, D.W. Novotny, "A new induction motor V/f control method capable of high-performance regulation at low speeds, " *Vol. 34, No. 4, July/August 1998*, pp. 813 - 821.
- [16] A. Oteafy, J. Chiasson, A Study of the Lyapunov Stability of an Open-Loop Induction Machine *IEEE Transactions on Control Systems Technology*, Vol. 18 , No. 6, Nov. 2010, pp. 1469 - 1476.
- [17] L. Meng, S. Yang, L. Wang, V. Liu and F. Peng "Hardware-In-Loop Test for Automatic Voltage Regulator based on identification Model" *15th International Power Electronics and Motion Control Conference, ECCE Europe*, Novi Sad, Serbia, EPE-PEMC 2012