

Determination of Self-excited Vibration Criterion for Strip Rolling Mills

LING MA, YONGQIN WANG*, YUANXIN LUO, XINGCHUN YAN

College of Mechanical Engineering,

Chongqing University,

Shazheng Street, Shapingba, Chongqing, 400044

CHINA

wyq@cqu.edu.cn

<http://teacher.cme.cqu.edu.cn/index.asp?id=92&sbm=0F7D0D63-396B-458A-A6E1-45BEFCE46054>

Abstract: - Self-excited vibration has been occasionally observed with a nature frequency of the mill stand during the strip rolling process. The root cause of this phenomenon has not been clearly explained yet. In general, it is related with rolling reduction ratio, rolling speed, frictional condition and material mechanics etc. According to the evolution of vibration amplitude, self-excited vibration can be classified into stable type with decreasing amplitude and unstable type with increasing amplitude by a critical condition where the vibration amplitude keeps unchanged. This critical condition is a criterion which can distinguish the type of self-excited vibration and help to escape the unstable self-excited vibration as well as prolong the rolling mill's lifetime. This paper is aimed to determine the self-excited vibration criterion of a typical rolling mill. Based on different solutions to the mill's differential vibration equations under different operational parameters, critical conditions mean that characteristic roots' real parts are either zero or negative. They constitute the criterion curve in corresponding operational parameter field. The differential vibration equations of rolling mill are simplified as a set of second-order equations by assuming that the deformation region of the strip is equivalent to springs and dampers. Then the equivalent damping and stiffness matrices can be calculated using 2D rigid-plastic FEM through applying perturbations of roll displacement and velocity. Compared with measured data, the predicted self-excited vibration criterion is proved to be reasonable. It's believed that this research will be meaningful to optimize the rolling operational parameters and avoid the occurrence of unstable self-excited vibration.

Keywords: - Rolling mill, Self-excited vibration, Perturbation, Rigid-plastic FEM

1 Introduction

Known as mechanical, hydraulic and automated system, the modern strip rolling mill has played an important role in strip rolling. However, it's found that the self-excited vibration happens occasionally with the nature frequency of the mill stand during the strip rolling process. This vibration excited by small perturbations can keep continuous and its amplitude can become stronger and stronger. It will lead to low quality of products as well as some structure damages [1]. The study of self-excited vibration is not much in existed literature. Some researchers tried to make their efforts to find the root cause of the vibration in cold or hot strip mills, but none has clearly understood or modelled this phenomenon yet [2] [3] [4].

In general, there are two different categories of self-excited vibration observed. One is torsional vibration of main drive system, and the other one is vibration of stand [5] [6] [7]. In this paper, the later

one is focused on. Some approaches have been employed to weaken self-excited vibration or avoid its occurrence. It's found that the measures to increase the friction damping or modify the structural dynamics are generally taken to solve these problems [8] [9] [10], but it's not always effective. Basically, as the strips move faster and are pressed harder, the mills are easy to vibrate like self-excited vibration, and make patterns on the strips and rolls, even interrupt the production [11] [12]. Thus, there is a limit for choosing the mills' rolling parameters to make thinner strips of high quality [13]. In the steel factory, the rolling parameters are constantly determined by the experienced engineers. However, this is not so effective for handling new materials and new strip shapes. Therefore, it's necessary to understand the self-excited vibration phenomenon clearly and obtain the criterion to guide the determination of the rolling parameters in order to skip the unstable self-excited vibration.

In recent years, Yoshida *et.al* [14] proposed a self-excited vibration model with consideration of the mechanical properties of material, rolling reduction ratio and rolling speed etc. The strip properties incorporate equivalent stiffness and damping matrices. The concept of this model is valuable, but the solution is not given specifically. Based on this concept, self-excited vibration of the stand is studied, and its vibration criterion is achieved in this research. The rest of this paper is organized as follow: section 2 presents the theoretical model of the self-excited vibration of rolling mill; in section 3, the elements of the equivalent stiffness and damping matrices are calculated using 2D rigid-plastic FEM by applying small perturbations of roll displacement and velocity; section 4 presents a case study of the mill stand and the results are compared to the measured data from Panzhuhua Iron and Steel Corporation; finally, the concluding remarks are given in Section 5.

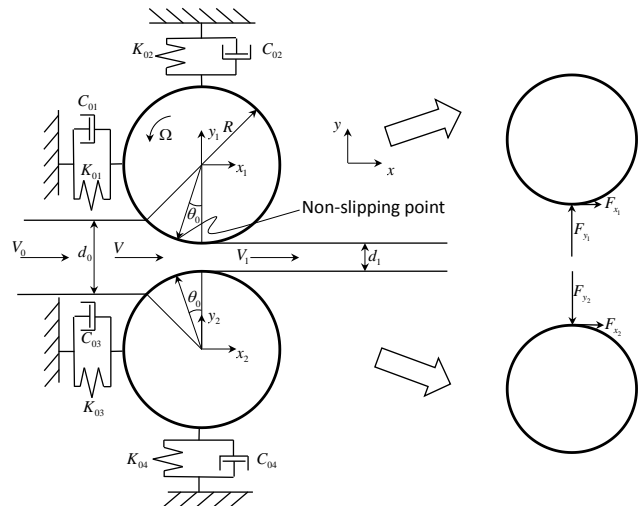

Fig. 1. A simplified roll-strip system

2 Self-excited vibration of rolling mill

Unlike most researches on the transverse vibration and vertical vibration of rolls which focused on forced vibration with periodic excitation source [15] [16], this paper is aimed at self-excited vibration. It is activated generally by small perturbations. In linear systems, unstable self-oscillation system is generally associated with a negative damping term, which causes increasement exponentially in amplitude until the system failure. It is the negative damping that forms positive energy feedback in vibration system and assists the system absorb energy from external automatically to maintain the vibration. It's difficult to find the root cause of forming negative damping; therefore, there is no exact solution to reduce the phenomenon. It's reported that the effective approach is to decrease the rolling speed and reduction ratio, but the relationship between these parameters is still not fully understood, which motivates us to model the system continually.

2.1 Model of the self-excited vibration

A typical strip rolling system is illustrated in Fig.1. The vertical and horizontal directions of each roll are considered to be independent, and the system can be described as 4-DOF system, \$x_1, y_1, x_2, y_2\$. The equivalent mass, damping, and stiffness of rolling mill are determined by mechanical system.

The dynamics equations of the rolls can be modelled by using Newton's Second Law:

$$M_0 \ddot{X} + C_0 \dot{X} + K_0 X = F \quad (1)$$

$$M_0 = \begin{bmatrix} m_1 & 0 & 0 & 0 \\ 0 & m_2 & 0 & 0 \\ 0 & 0 & m_1 & 0 \\ 0 & 0 & 0 & m_2 \end{bmatrix}, C_0 = \begin{bmatrix} c_{01} & 0 & 0 & 0 \\ 0 & c_{02} & 0 & 0 \\ 0 & 0 & c_{03} & 0 \\ 0 & 0 & 0 & c_{04} \end{bmatrix},$$

$$K_0 = \begin{bmatrix} k_{01} & 0 & 0 & 0 \\ 0 & k_{02} & 0 & 0 \\ 0 & 0 & k_{03} & 0 \\ 0 & 0 & 0 & k_{04} \end{bmatrix} \quad (2)$$

Where \$M_0\$ is equivalent mass matrix of the rolls, \$C_0\$ is the equivalent damping matrix of the mechanical system, \$F\$ is the equivalent force matrix acting on rolls and \$X\$ is roll displacement matrix.

In general case, the external force \$F\$ acting on the rolls is:

$$F(x, y, \dot{x}, \dot{y}, \dots) = F(\alpha_n) \quad (3)$$

Where \$\alpha_n\$ is the parameter of force function.

If the perturbations of displacement and velocity are small and can be linearized, the element of stiffness and damping matrices can be expressed as:

$$K_{ij} = \frac{dF_i}{dx_j} = \frac{\Delta F_i}{\Delta x_j} \quad (4)$$

$$C_{ij} = \frac{dF_i}{d\dot{x}_j} = \frac{\Delta F_i}{\Delta \dot{x}_j} \quad (i, j = x, y)$$

Substituting Eq. (4) into Eq. (3), we can get:

$$F(X, \dot{X}) = KX + C\dot{X} \quad (5)$$

Combining Eq. (5) and Eq. (1), we can get:

$$M_0 \ddot{X} + (C_0 - C)\dot{X} + (K_0 - K)X = 0 \quad (6)$$

Where $\ddot{X} = \begin{bmatrix} \ddot{x}_1 \\ \ddot{y}_1 \\ \ddot{x}_2 \\ \ddot{y}_2 \end{bmatrix}$, $\dot{X} = \begin{bmatrix} \dot{x}_1 \\ \dot{y}_1 \\ \dot{x}_2 \\ \dot{y}_2 \end{bmatrix}$, $X = \begin{bmatrix} x_1 \\ y_1 \\ x_2 \\ y_2 \end{bmatrix}$,

$$K_0 - K = \begin{bmatrix} k_{01} - k_{11} & -k_{12} & -k_{13} & -k_{14} \\ -k_{21} & k_{02} - k_{22} & -k_{23} & -k_{24} \\ -k_{31} & -k_{32} & k_{03} - k_{33} & -k_{34} \\ -k_{41} & -k_{42} & -k_{43} & k_{04} - k_{44} \end{bmatrix},$$

$$C_0 - C = \begin{bmatrix} c_{01} - c_{11} & -c_{12} & -c_{13} & -c_{14} \\ -c_{21} & c_{02} - c_{22} & -c_{23} & -c_{24} \\ -c_{31} & -c_{32} & c_{03} - c_{33} & -c_{34} \\ -c_{41} & -c_{42} & -c_{43} & c_{04} - c_{44} \end{bmatrix}.$$

Also, the Eq. (6) can be rewritten as:

$$m_1 \ddot{x}_1 + (c_{01} - c_{11}) \dot{x}_1 + (-c_{12}) \dot{y}_1 + (-c_{13}) \dot{x}_2 + (-c_{14}) \dot{y}_2 + (k_{01} - k_{11}) x_1 + (-k_{12}) y_1 + (-k_{13}) x_2 + (-k_{14}) y_2 = 0 \tag{7.a}$$

$$m_2 \ddot{y}_1 + (-c_{21}) \dot{x}_1 + (c_{02} - c_{22}) \dot{y}_1 + (-c_{23}) \dot{x}_2 + (-c_{24}) \dot{y}_2 + (-k_{21}) x_1 + (k_{02} - k_{22}) y_1 + (-k_{23}) x_2 + (-k_{24}) y_2 = 0 \tag{7.b}$$

$$m_1 \ddot{x}_2 + (-c_{31}) \dot{x}_1 + (-c_{32}) \dot{y}_1 + (c_{03} - c_{33}) \dot{x}_2 + (-c_{34}) \dot{y}_2 + (-k_{31}) x_1 + (-k_{32}) y_1 + (k_{03} - k_{33}) x_2 + (-k_{34}) y_2 = 0 \tag{7.c}$$

$$m_2 \ddot{y}_2 + (-c_{41}) \dot{x}_1 + (-c_{42}) \dot{y}_1 + (-c_{43}) \dot{x}_2 + (c_{04} - c_{44}) \dot{y}_2 + (-k_{41}) x_1 + (-k_{42}) y_1 + (-k_{43}) x_2 + (k_{04} - k_{44}) y_2 = 0 \tag{7.d}$$

Where M_0 , C_0 and K_0 are dependent on the rolling system. C and K are effective contact damping and stiffness matrices between strip and work rolls dependent on friction conditions and rolling parameters. It should be noted that C and K are the key factors to determine self-excited vibration criterion and will be presented in detail in Section 3.

2.2 Solution of the self-excited vibration equations

The governing equation of the dynamics system (Eq. (6)) is second-order and its general solution is:

$$x(t) = A \cdot e^{\lambda t} \tag{8}$$

Where, λ and A are parameters to be determined. Substituting it into Eq. (6), we can get:

$$M_0 A \lambda^2 + (C_0 - C) A \lambda + (K_0 - K) A = [M_0 \lambda^2 + (C_0 - C) \lambda + (K_0 - K)] A = 0 \tag{9}$$

If Eq. (9) has non-zero solution, λ should meet the equation described as follows:

$$\det(M_0 \lambda^2 + (C_0 - C) \lambda + (K_0 - K)) = 0 \tag{10}$$

Its characteristic roots are $\lambda_1, \lambda_2, \lambda_3, \lambda_4, \dots, \lambda_8$. The general solutions of differential equations are as follows:

$$X(t) = C_1 e^{\lambda_1 t} + C_2 e^{\lambda_2 t} + C_3 e^{\lambda_3 t} + C_4 e^{\lambda_4 t} + C_5 e^{\lambda_5 t} + C_6 e^{\lambda_6 t} + C_7 e^{\lambda_7 t} + C_8 e^{\lambda_8 t} \tag{11}$$

Where $X(t) = [x_1(t) \ y_1(t) \ x_2(t) \ y_2(t)]^T$, $C_i = c_i \times A^{(i)}$, $c_i = [k_1^{(i)} \ k_2^{(i)} \ k_3^{(i)} \ k_4^{(i)}]^T$, $A^{(i)} = [p_1^{(i)} \ p_2^{(i)} \ p_3^{(i)} \ p_4^{(i)}]^T$.

Eq. (11) indicates that characteristic roots determine the type of vibration, stable or unstable. If characteristic roots are real number, then any positives or zeroes would signify unstable self-excited vibration while absolute negatives would manifest stable vibration.

Furthermore, if characteristic roots are complex number, generally they are pairs of conjugate complex roots, and Eq. (11) becomes:

$$X(t) = \sum_{i=1}^8 C_i e^{\lambda_i t} = \sum_{i=1}^8 C_i e^{(a_i + b_i i) t} = \sum_{i=1}^8 C_i e^{a_i t} (\cos(b_i t) + i \sin(b_i t)) \tag{11}$$

Where $\lambda_1 = (a_1 + b_1 i)$, $\lambda_2 = (a_1 - b_1 i)$, ... This solution demonstrates that the vibration is periodic, and the amplitude changes with time. If real parts have any positives or zeroes, the amplitude would increase continuously, i.e. unstable self-excited vibration; otherwise it is stable vibration. However, if real parts are zeroes and negatives, the vibration is criterion, between convergent and divergent vibration.

In the criterion case, the roll trajectories are ellipses. The components in solution with negative real parts would vanish with time and the components with zero real parts are left, thus Eq. (11) can be rewritten as follows:

$$X(t) = [x_1(t), y_1(t), x_2(t), y_2(t)]^T = \begin{bmatrix} c_1 (\cos(b_1 t) + i \sin(b_1 t)) + c_2 (\cos(-b_1 t) + i \sin(-b_1 t)) \\ d_1 (\cos(b_1 t) + i \sin(b_1 t)) + d_2 (\cos(-b_1 t) + i \sin(-b_1 t)) \\ e_1 (\cos(b_1 t) + i \sin(b_1 t)) + e_2 (\cos(-b_1 t) + i \sin(-b_1 t)) \\ f_1 (\cos(b_1 t) + i \sin(b_1 t)) + f_2 (\cos(-b_1 t) + i \sin(-b_1 t)) \end{bmatrix} \tag{12}$$

Taking the top work roll for an example, eliminating t , we can get:

$$-c_1 c_2 y_1^2 - d_1 d_2 x_1^2 + (c_2 d_1 + c_1 d_2) x_1 y_1 = (c_2 d_1 - c_1 d_2)^2 \tag{13}$$

Let $x_1 = x_n \cos \theta - y_n \sin \theta, y_1 = x_n \sin \theta + y_n \cos \theta$, Eq. (13) can be rearranged as follows:

$$\frac{x_n^2}{a^2} + \frac{y_n^2}{b^2} = 1 \tag{14}$$

Where,

$$\tan 2\theta = \frac{c_1 d_2 + c_2 d_1}{c_1 c_2 - d_1 d_2}$$

$$a^2 = \frac{(c_2 d_1 - c_1 d_2)^2}{(c_2 d_1 + c_1 d_2) \sin \theta \cos \theta - c_1 c_2 \sin^2 \theta - d_1 d_2 \cos^2 \theta}$$

$$b^2 = \frac{(c_2 d_1 - c_1 d_2)^2}{-(c_2 d_1 + c_1 d_2) \sin \theta \cos \theta - c_1 c_2 \cos^2 \theta - d_1 d_2 \sin^2 \theta}$$

Thus, when the self-excited vibration is critical, the roll trajectory is ellipse, whose major axis and minor axis lie in a new coordinate system $x_n - y_n$. There is an angle θ between $x_n - y_n$ and $x_1 - y_1$, as shown Fig. 2.

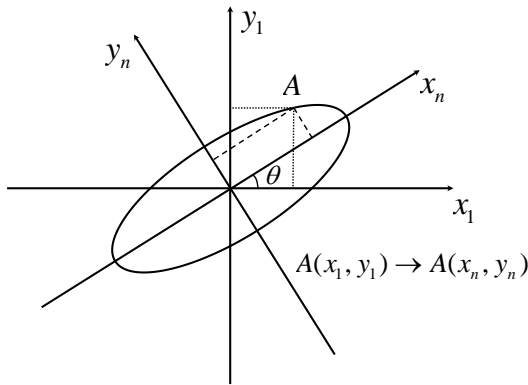

Fig. 2. Vibration trajectory of roll in critical condition

3 Obtaining stiffness and damping matrices using rigid-plastic FEM

When the perturbations are small, the changes on forces corresponding to displacement and velocity perturbations can be linearized. Recalling the definition of stiffness and damping, the ratio $\Delta F / \Delta x$ and $\Delta F / \Delta \dot{x}$ can be calculated as the stiffness K and damping C . Therefore the changes of forces acting on rolls resulting from the displacement and velocity perturbations could be obtained. By applying the perturbations to 2D models under certain reasonable boundary conditions, the changes of forces can be calculated using rigid-plastic FEM[17]. Different models corresponding to different perturbations are shown in Fig.3-5. Some treatments are shown in models in order to reduce the impact of outside rigid area as well as unknowns and improve the authenticity of simulating results.

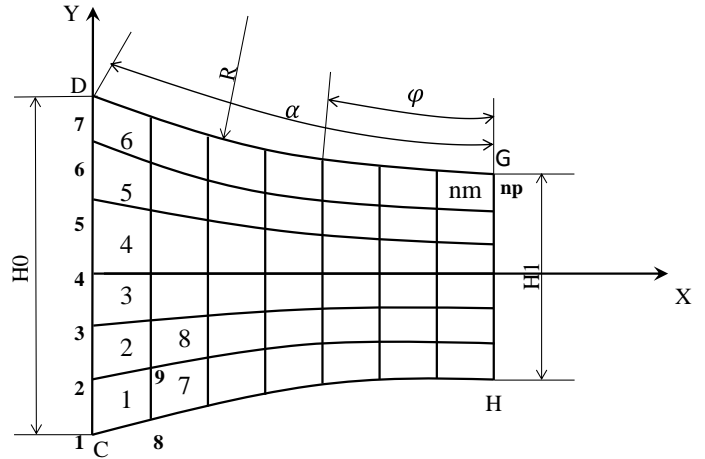

Fig. 3. Rolling model without perturbation / with velocity perturbation

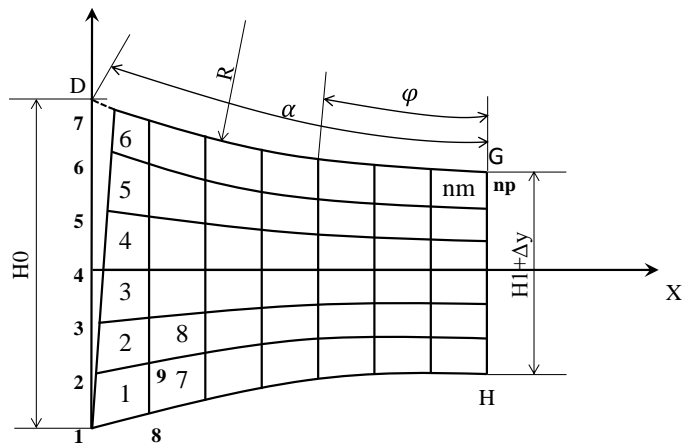

Fig. 4. Rolling model with a vertical displacement perturbation

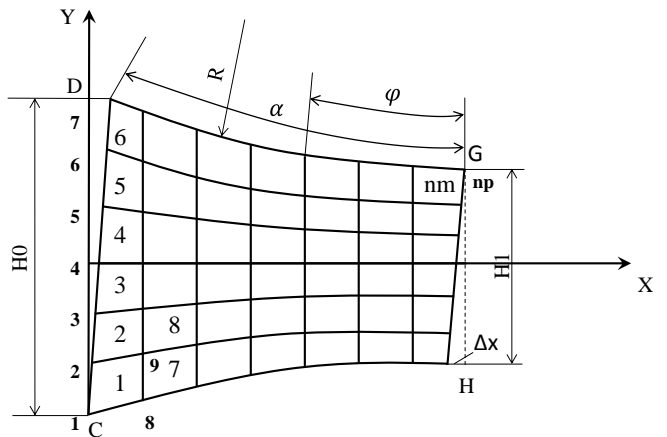

Fig. 5. Rolling model with a horizontal displacement perturbation

By evaluating the ratio $\Delta F / \Delta x$ which constitutes the stiffness matrix K , the change of force ΔF of each roll (upper and lower) at a different perturbed displacement Δx is obtained. Analogously, the ratio $\Delta F / \Delta \dot{x}$ is calculated, which makes up the matrix C , as shown in Fig.6-9. In this paper, the upper and lower parts of the mill are considered to be

symmetrical. Thus the relationship among K and C is as follows:

$$\begin{aligned} K_{33} &= K_{11}; K_{44} = K_{22}; K_{34} = -K_{12}; K_{13} = K_{31}; \\ K_{14} &= -K_{32}; K_{43} = -K_{21}; K_{23} = -K_{41}; K_{24} = K_{42}; \end{aligned} \quad (14)$$

$$\begin{aligned} C_{33} &= C_{11}; C_{44} = C_{22}; C_{34} = -C_{12}; C_{13} = C_{31}; \\ C_{14} &= -C_{32}; C_{43} = -C_{21}; C_{23} = -C_{41}; C_{24} = C_{42}; \end{aligned} \quad (15)$$

Thus, all of the elements of Eq. (4) are determined numerically and a complete set of matrices C and K are obtained.

For a rolling mill, operational parameters like reduction ratio, rolling speed, friction and yield stress of strip etc. can influence the occurrence of self-excited vibration. Different rolling operational parameters would result in different stiffness and damping matrices. Thus, for given strip material and frictional condition, stiffness and damping matrices could be regarded as the function of reduction ratio η and rolling speed v . Other factors' influences are supposed to be reflected in parameters of function. Assuming that:

$$\begin{aligned} K_{ij} &= as_1 \left(\frac{v}{c}\right)^{n_1} \eta^{n_2} \\ C_{ij} &= bs_2 \left(\frac{v}{c}\right)^{n_3} \eta^{n_4} \end{aligned} \quad (16)$$

Where s_1, s_2, n_1-n_4 are fitting parameters, the parameters a, b and c are defined as adjustment coefficients due to model simplification.

Substituting the Eq. (16) into Eq. (1) to solve the vibration equations, we can get 8 characteristic roots which still are the functions of η and v . Searching the condition where some characteristic roots' real part are zeros and the others are negatives in press ratio-speed domain, the criterion curve is acquired. The flow chart of this method is shown in Fig.10.

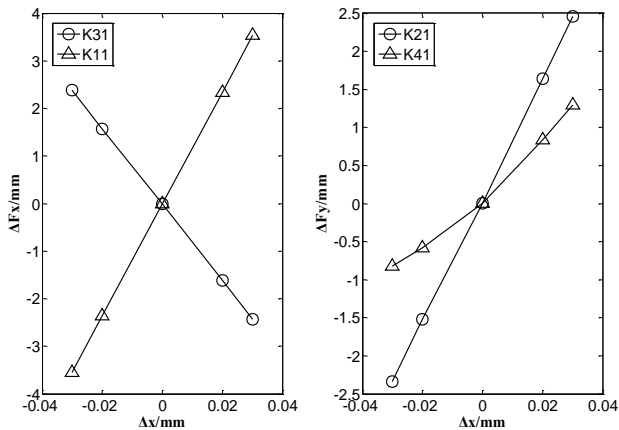

Fig. 6. Force change with a horizontal displacement perturbation

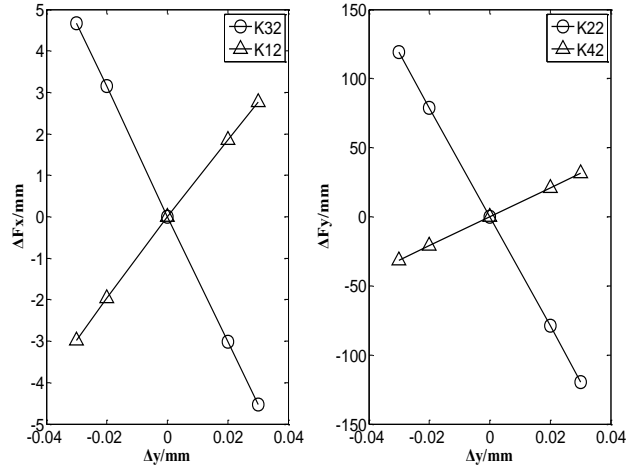

Fig. 7. Force change with a vertical displacement perturbation

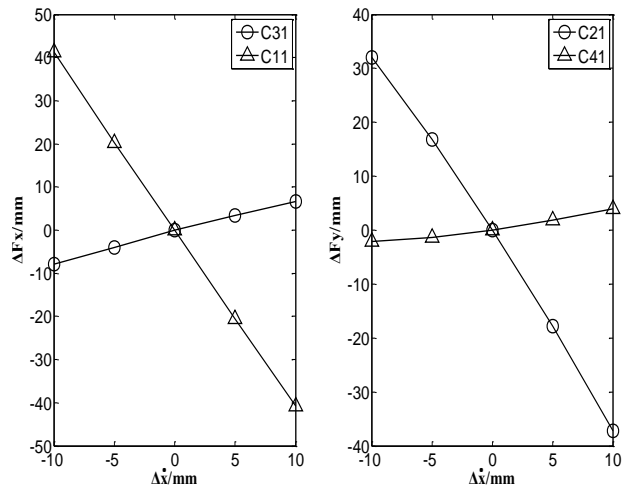

Fig. 8. Force change with a horizontal velocity perturbation

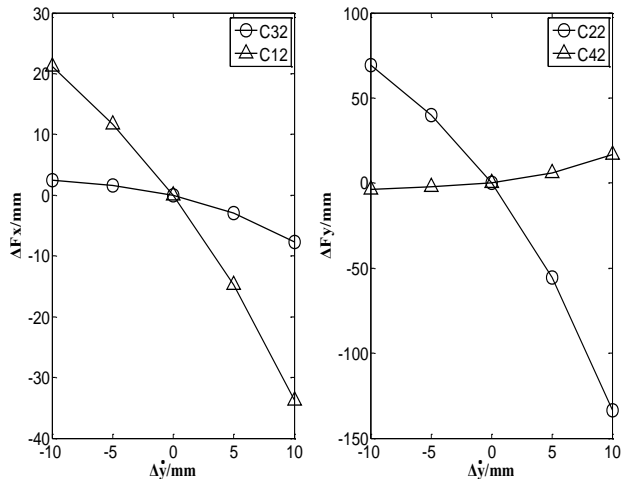

Fig. 9. Force change with a vertical velocity perturbation

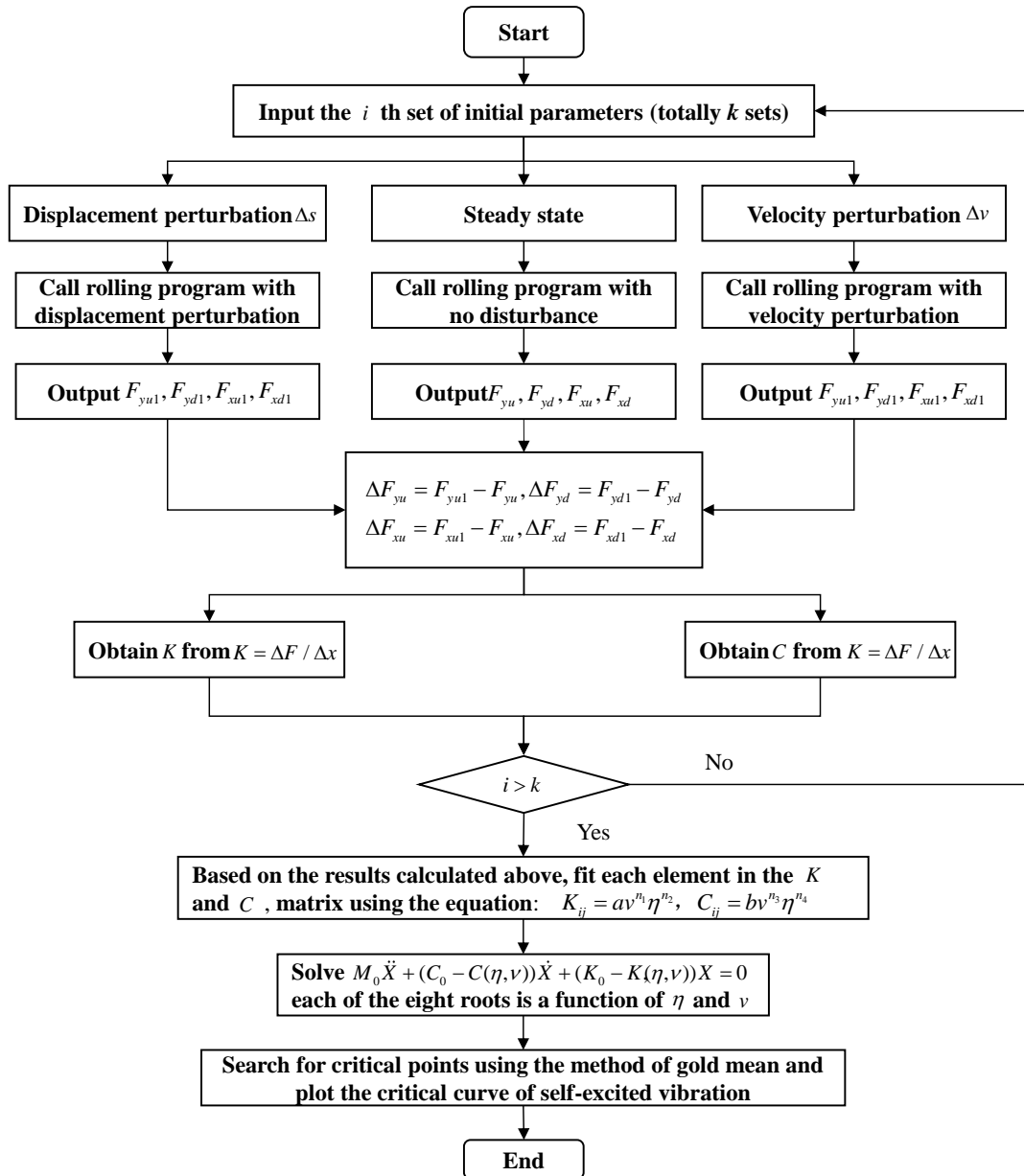

Fig.10. Flow chart of obtaining the vibration criterion curve

4 Application of the criterion curve of a rolling mill

According to measured data acquired from F2 rolling mill in 2050mm hot strip rolling line of Panzhihua Iron and Steel Corporation, the corresponding criterion curve can be calculated. Its roll diameter is 820mm; non-dimensional damping is 0.03; equivalent stiffness and mass of stand are $K_x = 5.4 \times 10^{10} N/m$, $K_y = 2.6 \times 10^{11} N/m$, $M_x = 1.4 \times 10^4 N/m$, $M_y = 1.4 \times 10^5 N/m$. Strip material is Q235, thus the yield stress is 235Mpa. Friction coefficient is 0.35.

4.1 Acquisition of C and K of strip in rolling mill

In the above-mentioned condition, the first step is calculating the stiffness and damping matrices in different press ratios or rolling speeds using rigid-plastic FEM. Next is fitting Eq. (16) based on achieved stiffness and damping data. The fitting parameters are shown in Table 1 and Table 2 for the case of a=5, b=35, c=8. From the fitting results, it is found that elements in damping matrices are proportional to the inverse of the rolling speed as $1/v$

basically, while the relationship between stiffness matrices and rolling speed is not notable, which is consistent with the results of M. Yoshida [14].

4.2 Criterion curve of self-excited vibration

Since 8 characteristic roots are the functions of η and ν , the criterion curve will be achieved by searching the condition where characteristic roots' real part are either zeros or negatives in press ratio and speed domain. The comparison of calculated results and measured data is shown in Fig.11, the

curve represents the criterion of self-excited vibration and five-pointed stars represent actual measurements. It is obvious that the curve is in good agreement with the fact.

If rolling parameters locate in the left hand of the criterion curve, the self-excited vibration is stable. Otherwise, the vibration is unstable. Especially, if they stay on the criterion curve, the amplitude of vibration is neither increasing nor decreasing and the system would keep vibration continuously. Typical trajectories of rolls and vibration waveforms in different conditions are shown in Fig.12-17.

Table 1 Fitting parameters in elements of damping matrix

Item	C11	C21	C21	C22	C31	C32	C41	C42
$s_1 (\times 10^6)$	-20.6	-3.14	-11.6	-44.6	3.33	-3.35	0.032	-1.92
n_1	-0.40	-1.17	-0.91	-0.47	-0.78	-1.55	-4.2	1.25
n_2	-1.04	-0.85	-1.29	-1.02	-1.11	-1.96	-1.5	-0.16
correlation coefficient	0.98	0.91	0.96	0.97	0.91	0.96	0.96	0.91

Table 2 Fitting parameters in elements of stiffness matrix

Item	K11	K12	K21	K22	K31	K32	K41	K42
$s_2 (\times 10^7)$	7.8	2.25	2.8	-237	-10.8	-104	8.8	156
n_3	-0.33	-1.7	-1.25	-0.42	0.46	2.87	1.24	0.56
n_4	-0.06	-0.083	-0.2	-0.01	0.06	0.14	0.29	0.05
correlation coefficient	0.93	0.84	0.93	0.97	0.94	0.98	0.84	0.97

4.3 Prediction of vibration type

If the rolling parameters or strip material need to change, using the developed method can give a prediction that whether the unstable self-excited vibration would occur in that condition and help people to determine appropriate rolling parameters.

Take the above mentioned rolling mill for an example, when it was in the condition that the thickness of strip entrance was 15.67mm, rolling speed was 2280mm/s and press ratio was 0.542, obvious vibration was observed on the spot. This is

consistent with the numerical results calculated by developed method. SS are 8 Characteristic roots of these differential equations, shown as follows. Fig.18-19 are trajectories of rolls and vibration waveforms in this condition.

$$\begin{aligned} SS = & 16.7635191797153 \pm 1910.20470796588i \\ & -378.537148204286 \pm 1909.47447008261i \\ & -42.1418498537406 \pm 1355.90005903609i \\ & -615.884767679613 \pm 1837.49591197475i \end{aligned}$$

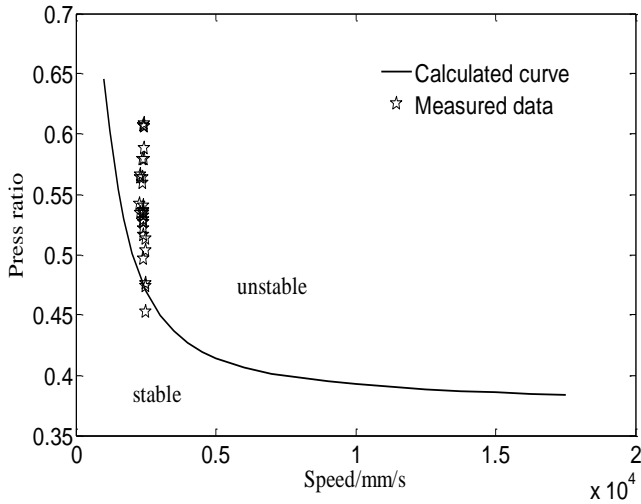

Fig. 11. Criterion curve of vibration and measured data under a given rolling mill

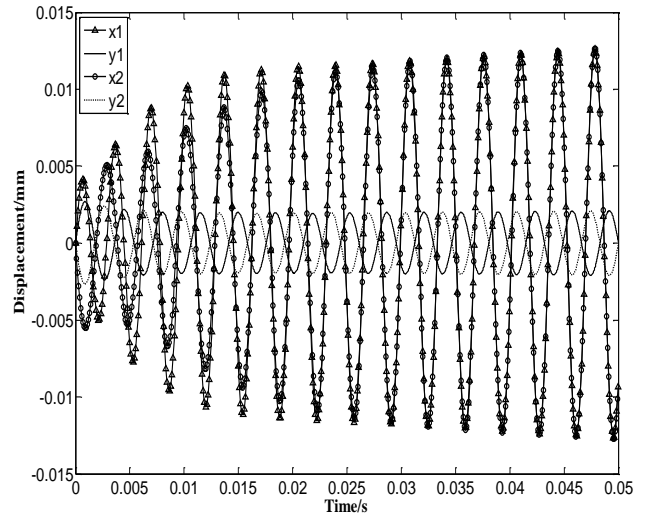

Fig. 14. Waveform of criterion vibration in the direction of 4 DOFs

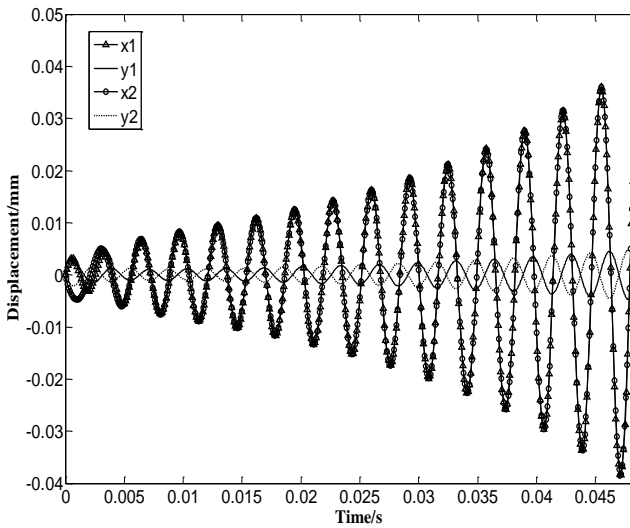

Fig. 12. Waveform of divergent vibration in the direction of 4 DOFs

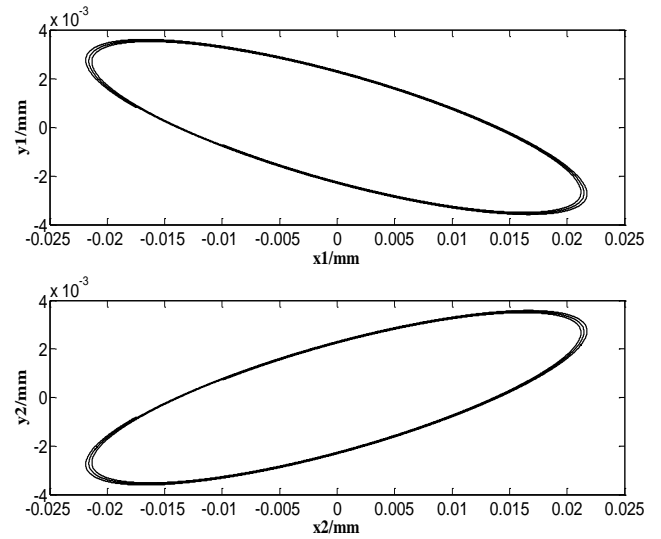

Fig. 15. Upper and lower rolls' trajectories of criterion vibration

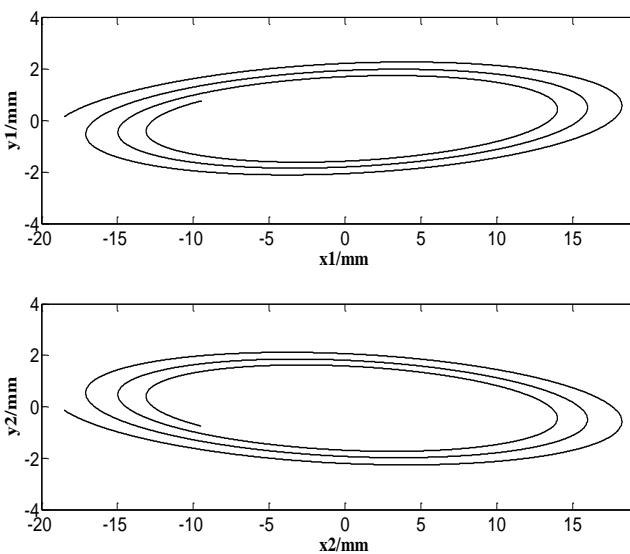

Fig. 13. Upper and lower rolls' trajectories of divergent vibration

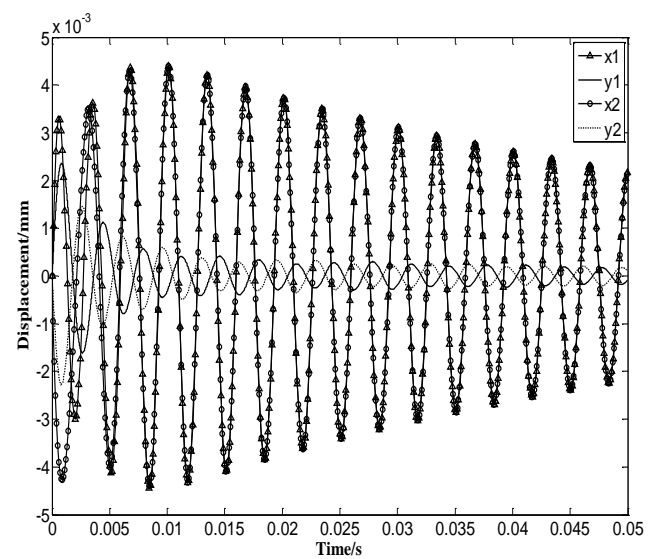

Fig. 16. Waveform of convergent vibration in the direction of 4 DOFs

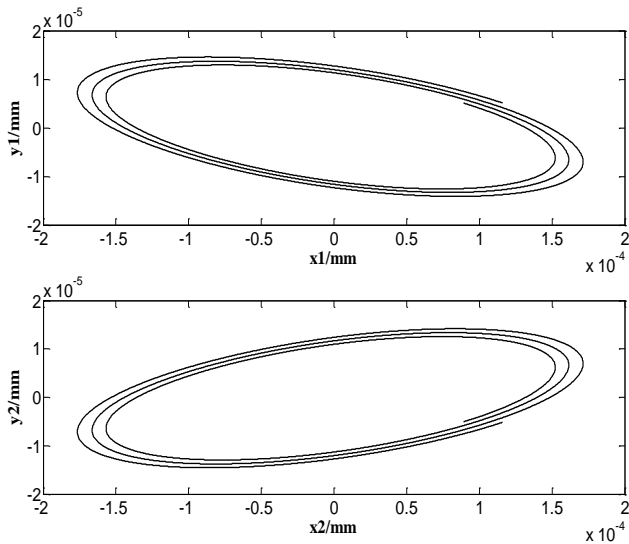

Fig. 17. Upper and lower rolls' trajectories of convergent vibration

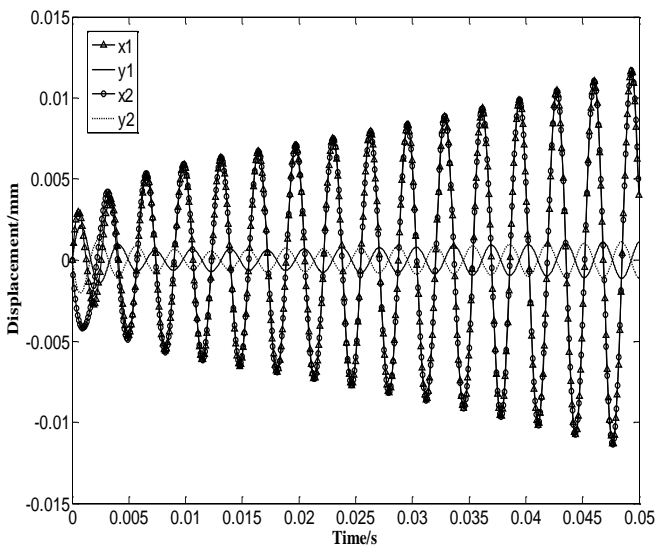

Fig. 18. Waveform of vibration in the direction of 4 DOFs

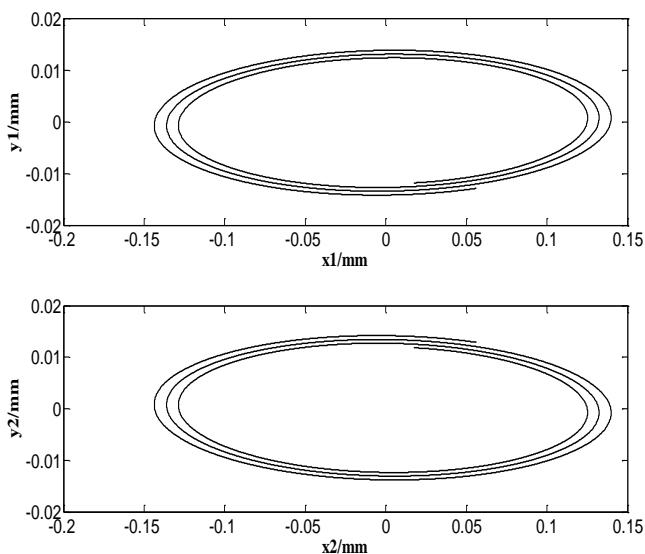

Fig.19. Upper and lower rolls' trajectories of vibration

5 Conclusion

To further understand the self-excited vibration of rolling mill, this research presents a model of the mill system for determining the self-excited vibration criterion. It should be noted that the strip rolling process is simulated by rigid plastic FEM. It can calculate the force change due to the perturbations reasonably. By fitting the parameters in the function of press ratio η and rolling speed v , the elements of stiffness matrix and dumping matrix are obtained. Then the criterion curve of self-excited vibration of the rolling mill is calculated using the search method of golden mean. According to the comparison of measured data and calculated results, following conclusions are made:

- 1) The criterion curve obtained by the proposed method agrees quite well with measured data, even though this approach contains some hypotheses. It's believed that this research will help to optimize the rolling operational parameters and avoid the occurrence of self-excited vibration.
- 2) The rolls' vibration trajectories are predicted. Especially when the self-excited vibration is critical, the trajectories of work rolls are ellipses, whose major axis and minor axis lie in a new coordinate system. The angle θ between the new coordinate system and the old one is dependent on the initial conditions.
- 3) Also, the calculation shows that the damping factor is proportional to the inverse of the strip speed as $1/v$. This result explains the shape of the criterion curve qualitatively.

As a next step, the effect of friction should be investigated. It is important because of not only its value but also its relevance with the slipping velocity. Thus, carrying some experiments using a two-roll contact slipping system and considering the coefficient of friction as the function of slipping velocity are meaningful. Moreover, the strip motion between tandem mills should be simulated by treating the strip as plastic material instead of rigid-plastic material. This means that a more accurate FEM model is needed. In addition, influences of back-up rolls should be considered to investigate the mechanism of the vibration more clearly in the future.

Reference:

- [1] Xiong Shi-bo, Wang Ran-feng, Liang Yi-wei, Ma Wei-jin, Xiong Xiao-yan, Self-excited vibration diagnosis of the rolling mills and structure dynamics modification, *Chinese*

- Journal of Mechanical Engineering*, Vol.41, No.7, 2005, pp. 147-151.
- [2] Pawelski O, Rasp W and Friedewald K. Application of the theory of rolling to rolling in the case of mill vibrations. *Steel Research International*, Vol.57, No.8, 1986, pp. 373-376.
- [3] Pawelski O, Rasp W and Friedewald K. Chattering in cold rolling-Theory of interaction of plastic and elastic deformation. *Proceedings of 4th International Steel Rolling Conference on the Science and Technology of Flat Rolling*, Deauvill, France, 1987, 1-3 June, pp. 2: E.11.1-E.11.5.
- [4] Zhong Jue, Tang Hua-pin. Vibration problems of high speed rolling mill-study of dynamics of complex electromechanically coupled system, *Journal of Vibration*, Vol.22, No.1, 2002, pp. 1-9.
- [5] Zhang Rui-cheng, Tong Chao-nan. Torsional Vibration Control of the Main Drive System of a Rolling Mill Based on an Extended State Observer and Linear Quadratic Control, *Journal of Vibration and Control*, vol.12, No.3, 2006, pp. 313-327.
- [6] Sun Zhi-hui, Zou Jia-xiang, He Ru-yin, Yue Hai-long, Vibration analysis of 2030 cold continuous mill, *Journal of University of Science and Technology Beijing*, Vol.19, No.2, 1997, pp. 61-64.
- [7] Hu P, Kornel F. Ehmann, Stability analysis of chatter on a tandem rolling mill, North American Manufacturing Research Conference, Berkeley, California, Vol.27, 1999, pp. 61-66.
- [8] Ma Wei-jin, Li Feng-lan, Xiong shi-bo, Analysis and Diagnosis of Self-Excitation-Vibration of Hot Rolling Mill, *Journal of Vibration, Measurement and Diagnosis*, Vol.26, No.4, 2006, pp. 261-328.
- [9] Lu Xiao-yan, Ye Qian-yuan, Qu Zhi-hao, Analysis and solution of the self-excited vibration on a rolling mill, *Journal of University Of Shanghai for Science and Technology*, Vol.26, No.2, 2004, pp. 141-145.
- [10] Yukio I, Recent development of the passive vibration control method, *Mechanical Systems and Signal Processing*, Vol.29, No.1, 2012, pp. 2-18.
- [11] Nettelbeck L, Ungerer W, Weber J *et.al* , Latest findings on chatter vibration in cold rolling mills and survey of reduction measures. *New developments in metallurgical process technology-International Conference METEC Congress*, 1999, pp. 356-363.
- [12] Yukio K, Yasuhiro S, Nobuo N, Analysis of chatter in tandem cold rolling mills. *ISIJ International*, Vol.43, No.1, 2003, pp. 77-84.
- [13] Ubichi E, Borda M, Klempnow A *et.al*, Identification and countermeasures to resolve hot strip mill chatter. *AISE Steel Technology*, Vol.78, No.6, 2001, pp. 48-52.
- [14] Yoshida M, Furumoto H *et.al*, New approach to calculating a dynamically stable criterion for hot strip mills. *Proceedings of the Institution of Mechanical Engineers, Part K: Journal of Multi-body Dynamics*, Vol.217, No.2, 2003, pp.135-143.
- [15] Sun Jian-liang, Peng Yan, Liu Hong-min, Jiang Guang-biao, Forced transverse vibration of rolls for four-high rolling mill, *Journal of Central South University of Technology (English edition)*, Vol.16, No.6, 2009, pp. 0954-0960.
- [16] Fan Xiao-bin, Zang Yong, Wu Di-ping, Wang Yong-tao, Liao, Yi-fan. Huang hi-jian. Vibration problems of CSP hot tandem mill. *Chinese Journal of Mechanical Engineering*, Vol.43, No.8, 2007, pp. 198-201.
- [17] Osakada K, Nakano J, Finite element method for rigid-plastic analysis of metal forming formulation for finite deformation. *International Journal of Mechanical Sciences*, Vol.24, No.8, 1982, pp. 459-468.